

[54] MOTORCYCLE FAIRING

[75] Inventor: Eitaro Kamata, Shimbashi, Japan

[73] Assignee: Shoei Safety Helmet Corporation, Los Angeles, Calif.

[\*\*] Term: 14 Years

[21] Appl. No.: 56,953

[22] Filed: Jul. 12, 1979

[51] Int. Cl. .... D12-11

[52] U.S. Cl. .... D12/182

[58] Field of Search ..... D12/182; 296/78.1

[56] References Cited

PUBLICATIONS

Cycle World, 3/78, P63, Motorcycle Fairing, top of page.

Cycle World, 6/75, P84, Motorcycle Fairing, bottom of page.

Primary Examiner—James M. Gandy  
Attorney, Agent, or Firm—Freilich, Hornbaker, Wasserman, Rosen & Fernandez

[57] CLAIM

The ornamental design for a motorcycle fairing, substantially as shown and described.

DESCRIPTION

FIG. 1 is a right side and front perspective view of a motorcycle fairing showing my new design.

FIG. 2 is a right side and rear perspective view thereof.

FIG. 3 is a front elevation view thereof.

FIG. 4 is a right side elevation view thereof, the left side being a mirror image of the right side shown.

FIG. 5 is a cross sectional view thereof taken along line 5-5 in FIG. 3.

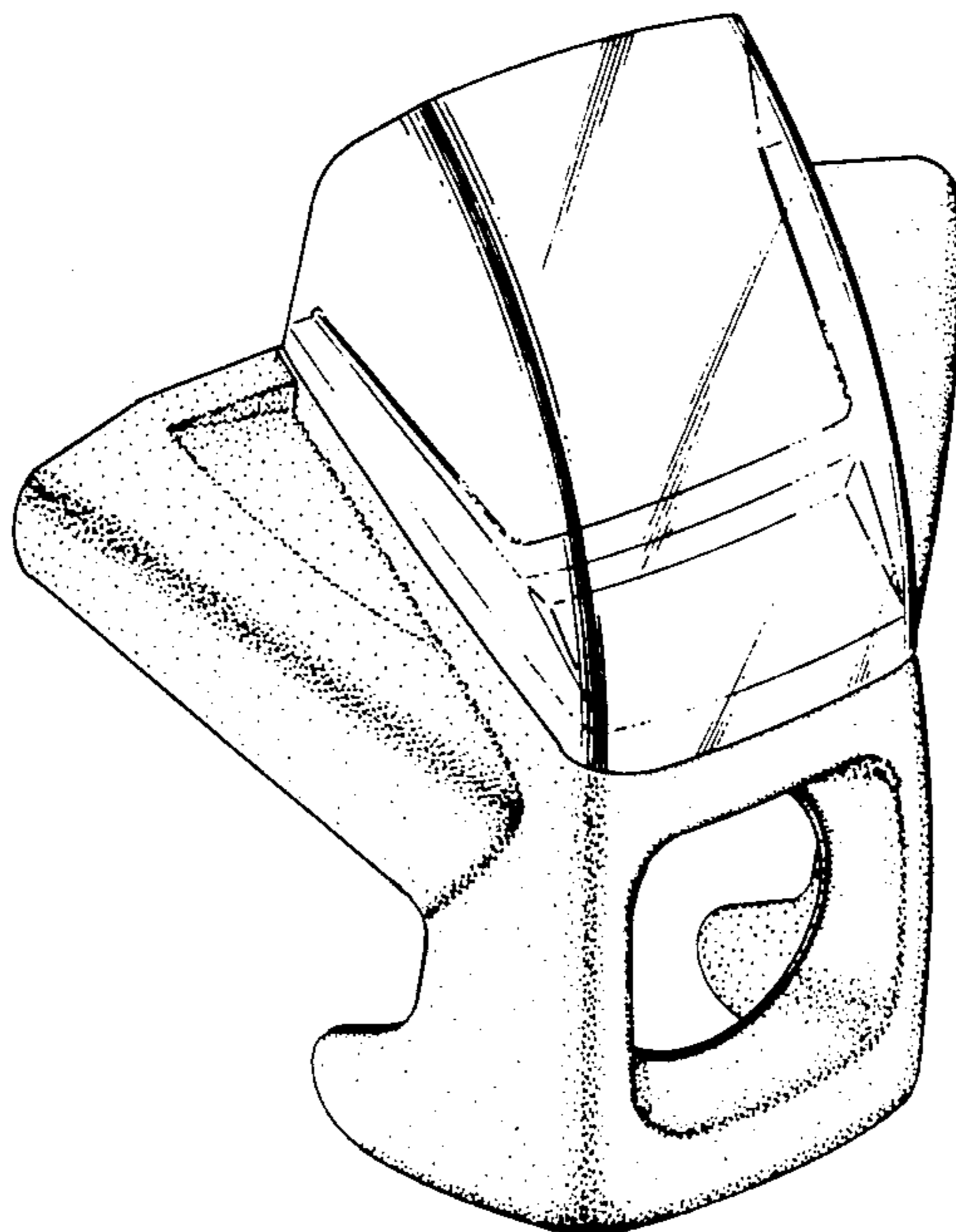

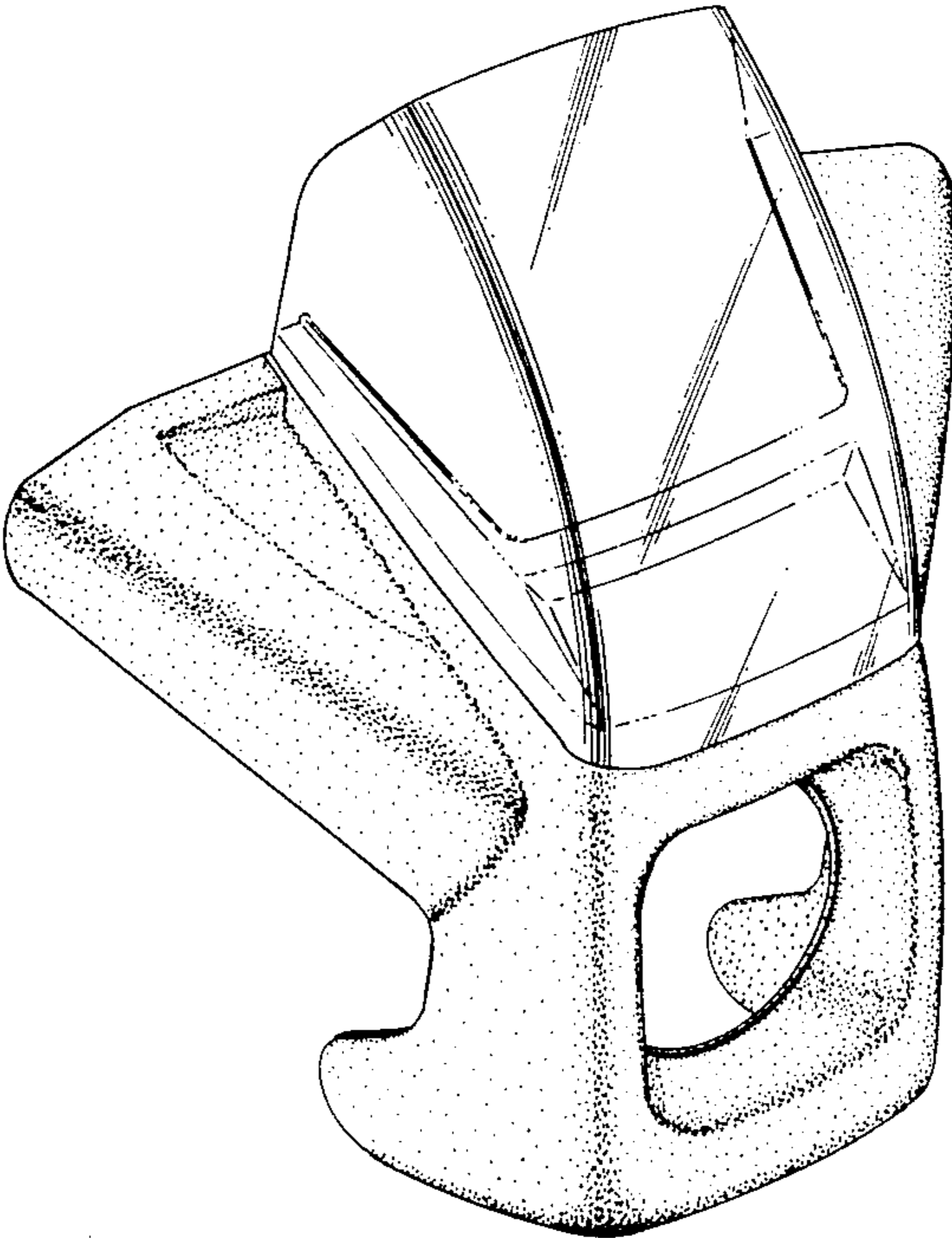

FIG. 1

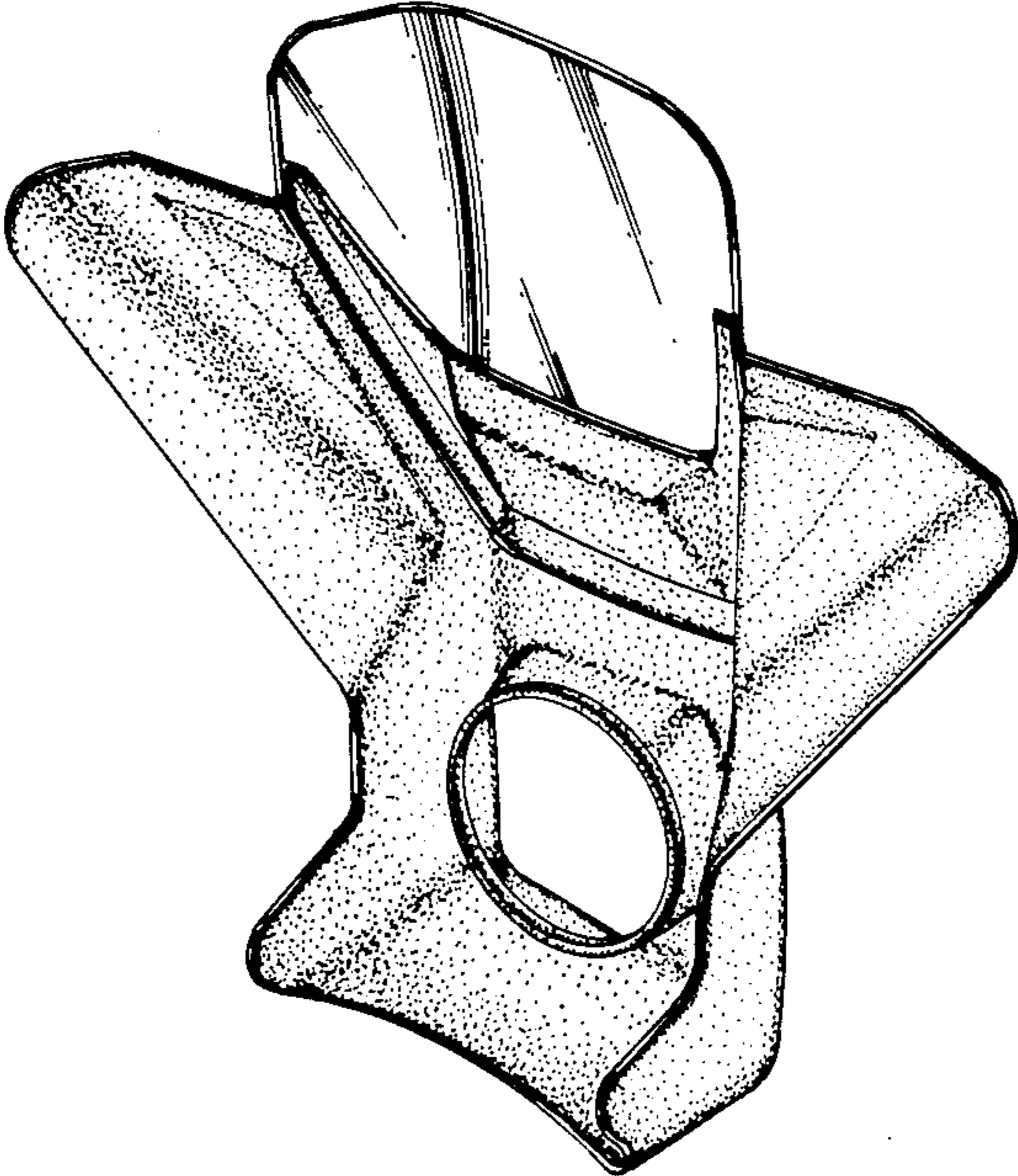

FIG. 2

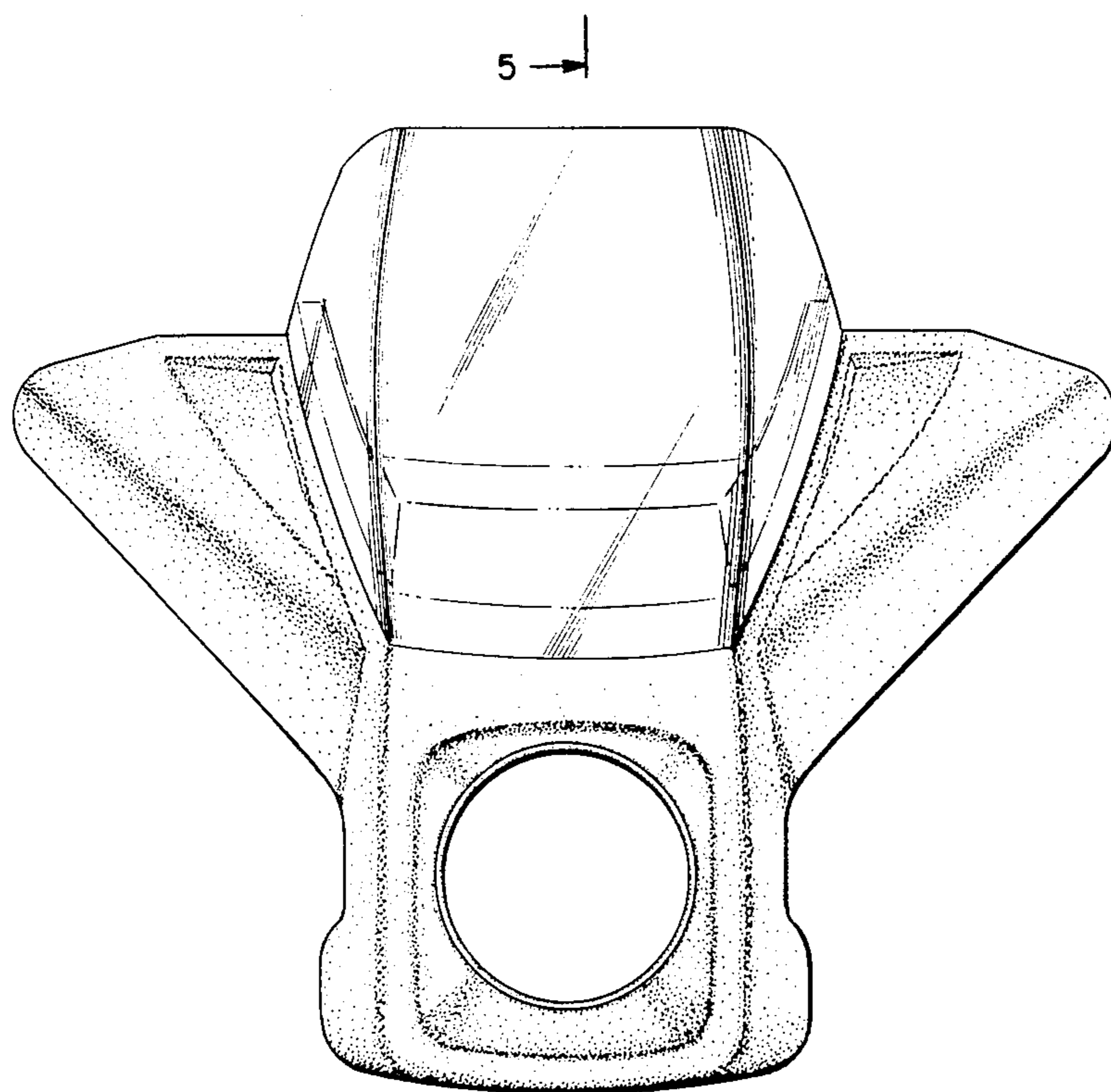

FIG. 3

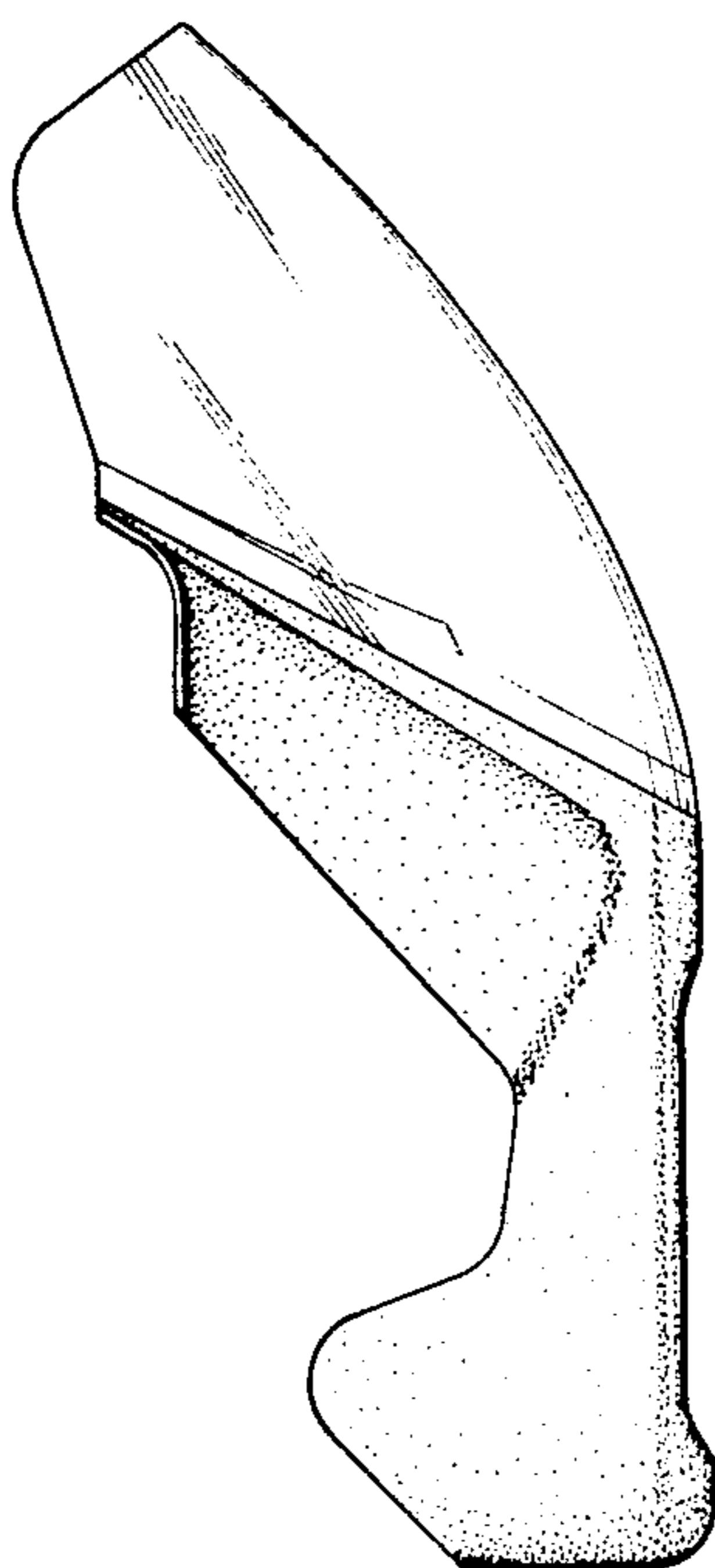

FIG. 4

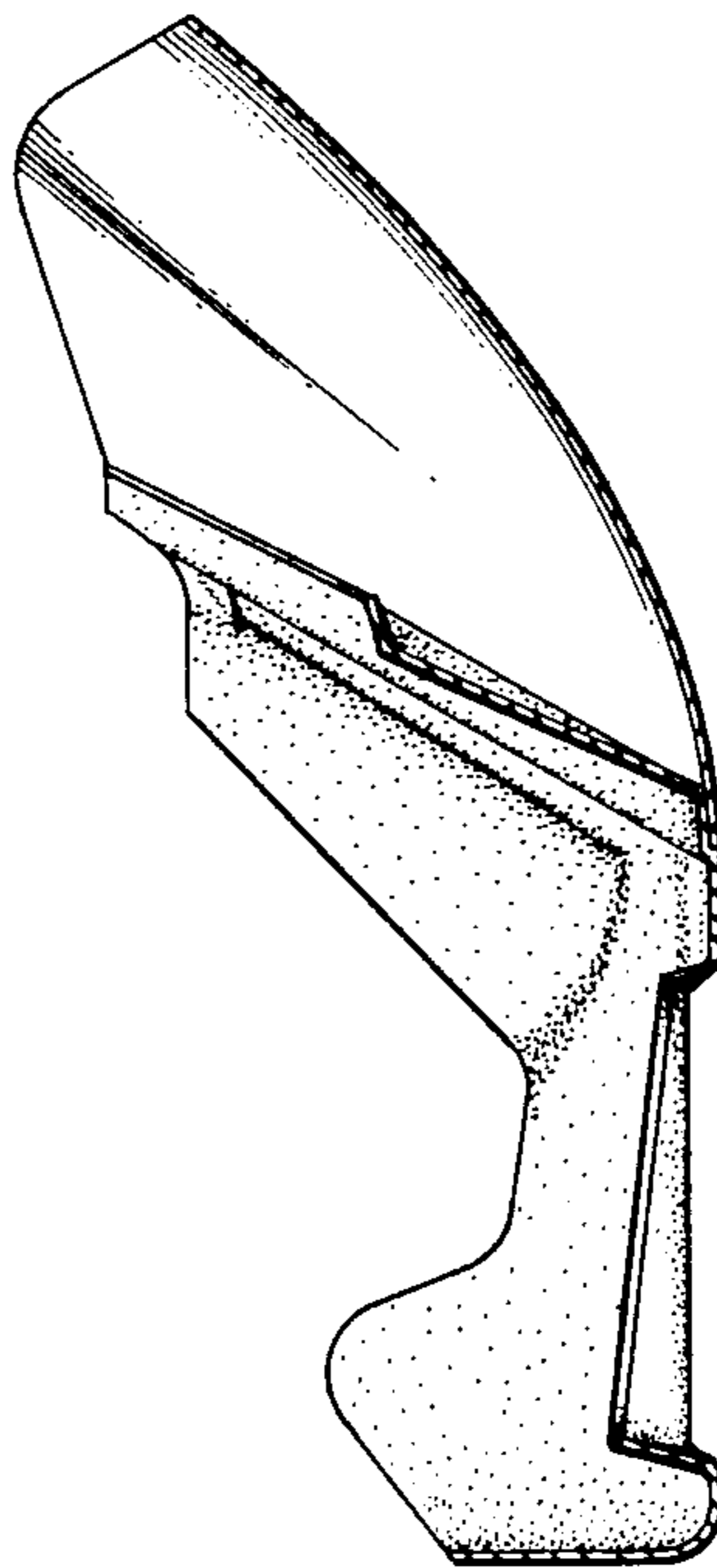

FIG. 5