

[54] TOY AIRPLANE

[76] Inventor: Robert H. Enzman, 1142 Elm St., Reading, Pa. 19601

[**] Term: 14 Years

[21] Appl. No.: 913,529

[22] Filed: Jun. 7, 1978

[51] Int. Cl. D21-01

[52] U.S. Cl. D21/90

[58] Field of Search D21/87, 88, 90, 91, D21/129; 46/74.76 R, 77, 78, 79, 80, 81; D12/73

[56] References Cited

U.S. PATENT DOCUMENTS

D. 195,859 8/1963 Johnson et al. D21/129

D. 250,727 1/1979 Venditti D21/89
D. 251,865 5/1979 Butler D21/90
3,721,317 3/1973 Gay et al. 46/78

Primary Examiner—Charles A. Rademaker
Attorney, Agent, or Firm—William J. Ruano

[57] CLAIM

The ornamental design for a toy airplane, substantially as shown and described.

DESCRIPTION

FIG. 1 is a top plan view of a toy airplane showing my new design;

FIG. 2 is a right side elevational view thereof;

FIG. 3 is a bottom plan view thereof;

FIG. 4 is a left side elevational view thereof;

FIG. 5 is a front elevational view thereof; and,

FIG. 6 is a rear elevational view thereof.

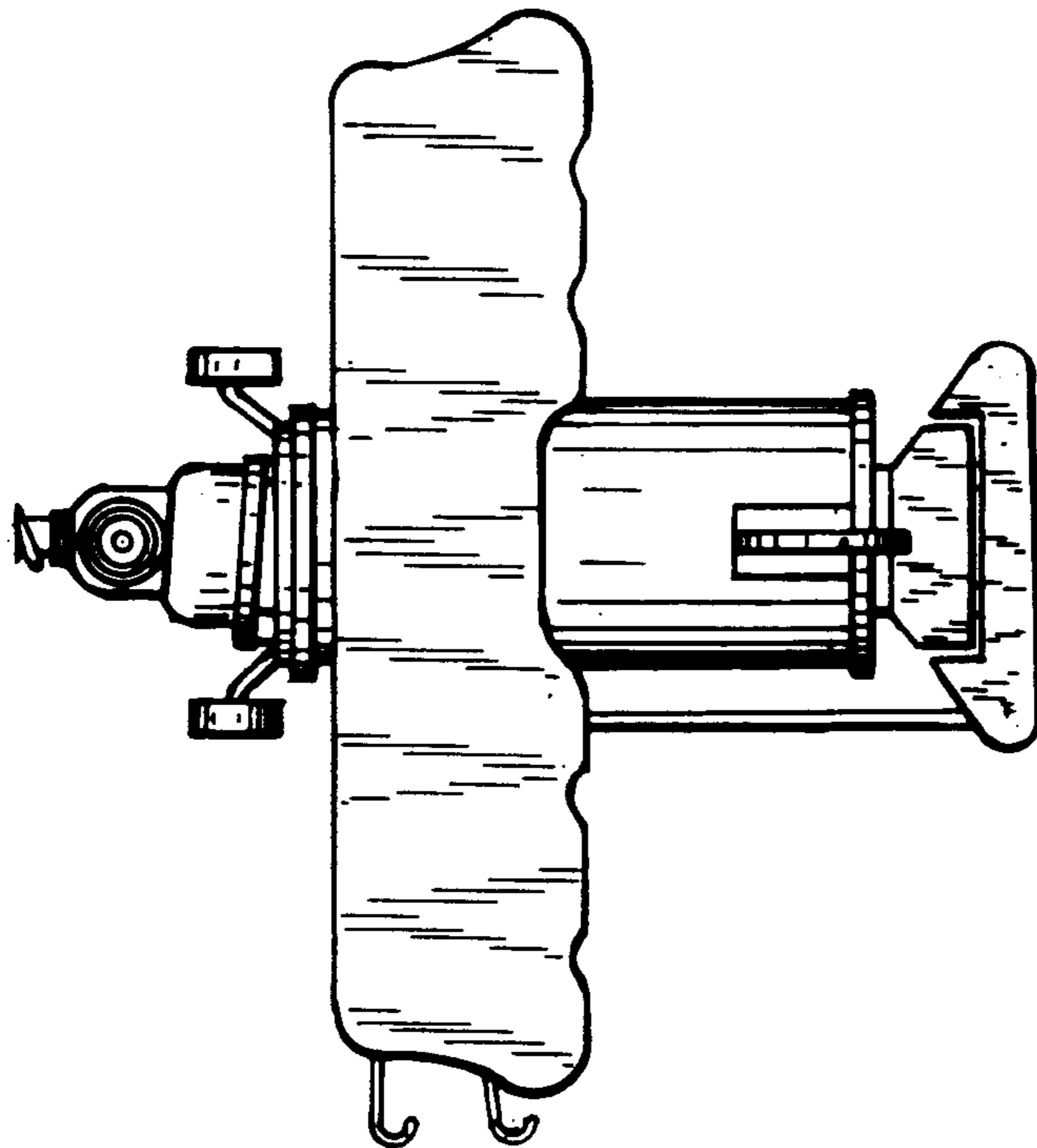

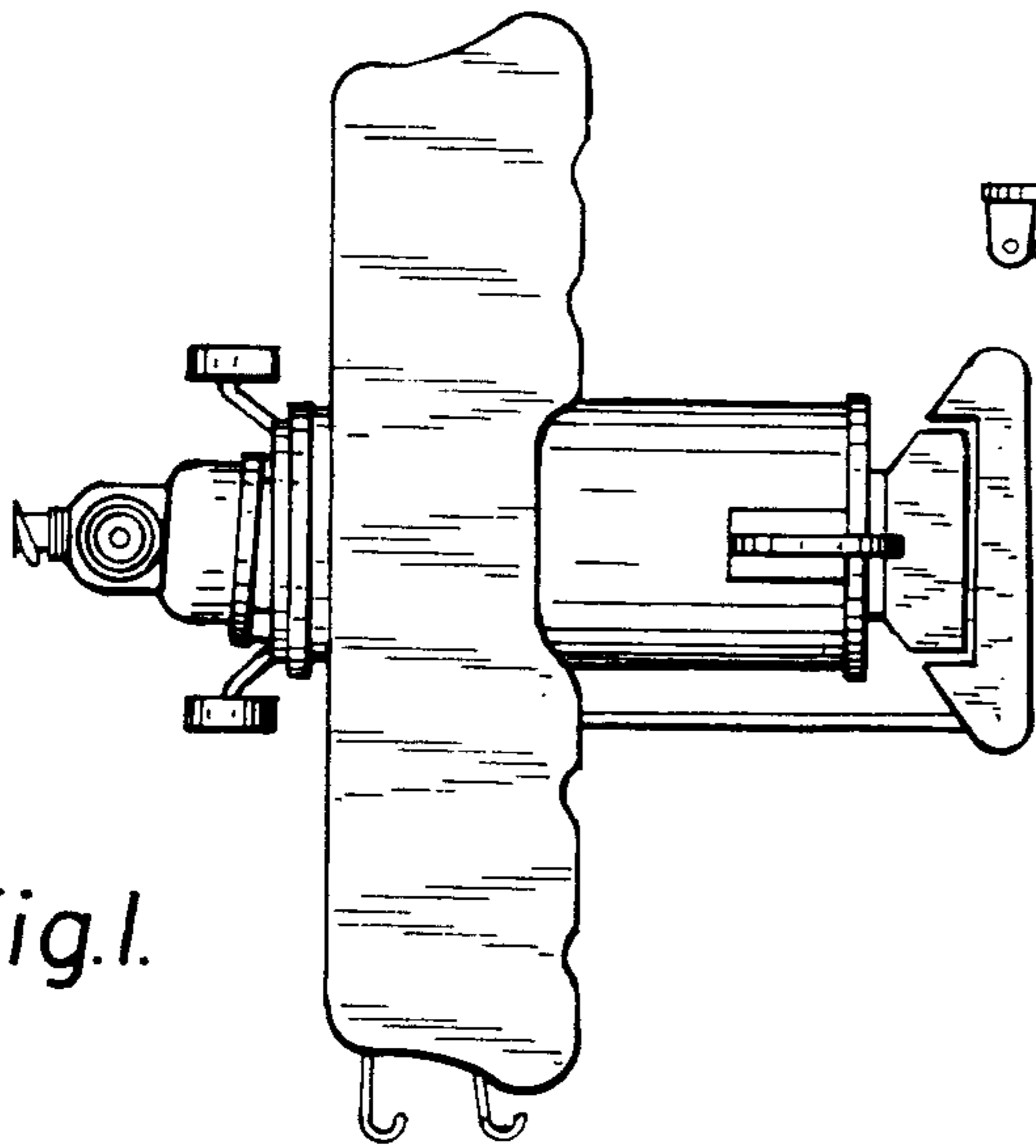

Fig. 1.

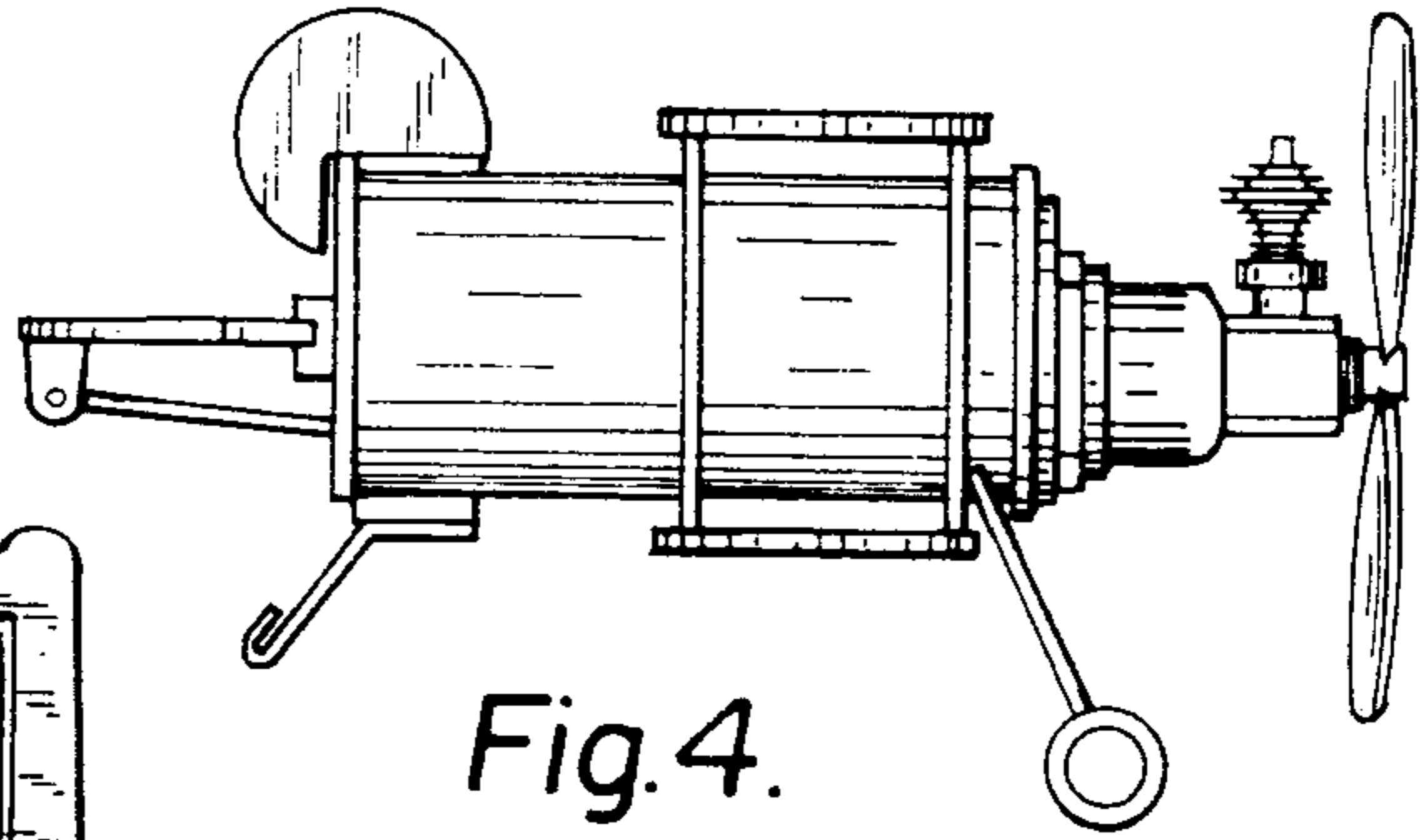

Fig. 4.

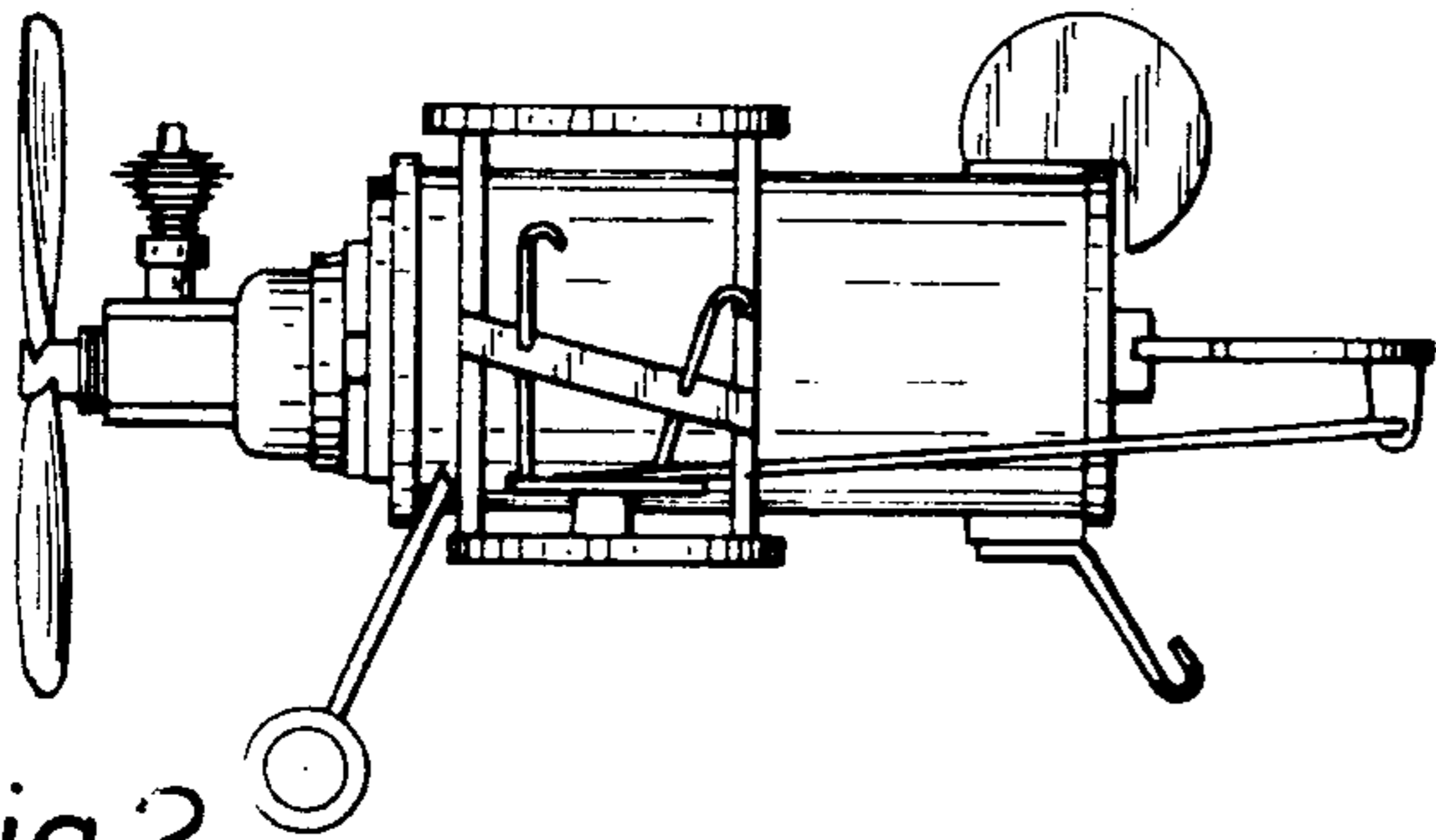

Fig. 2.

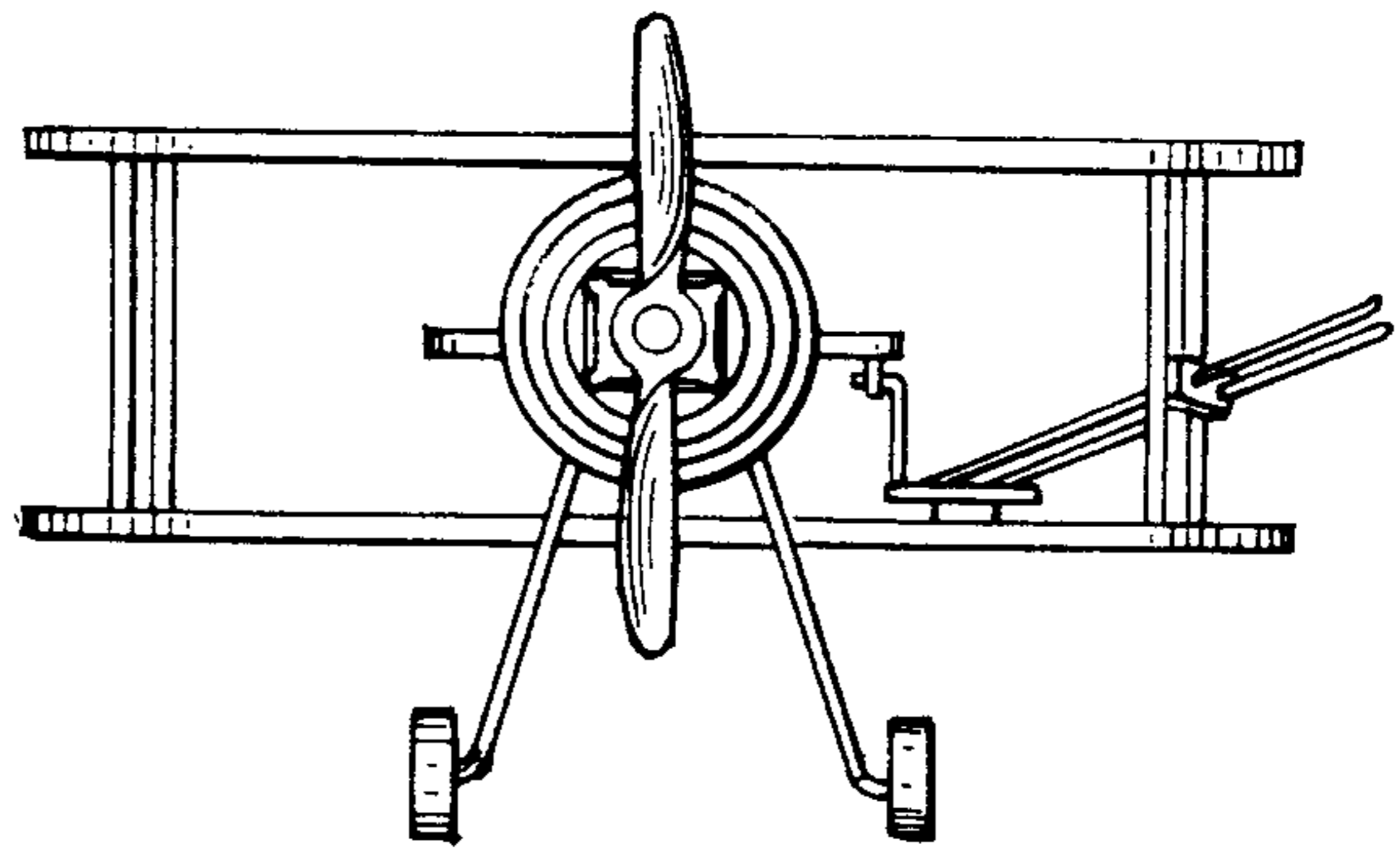

Fig. 5.

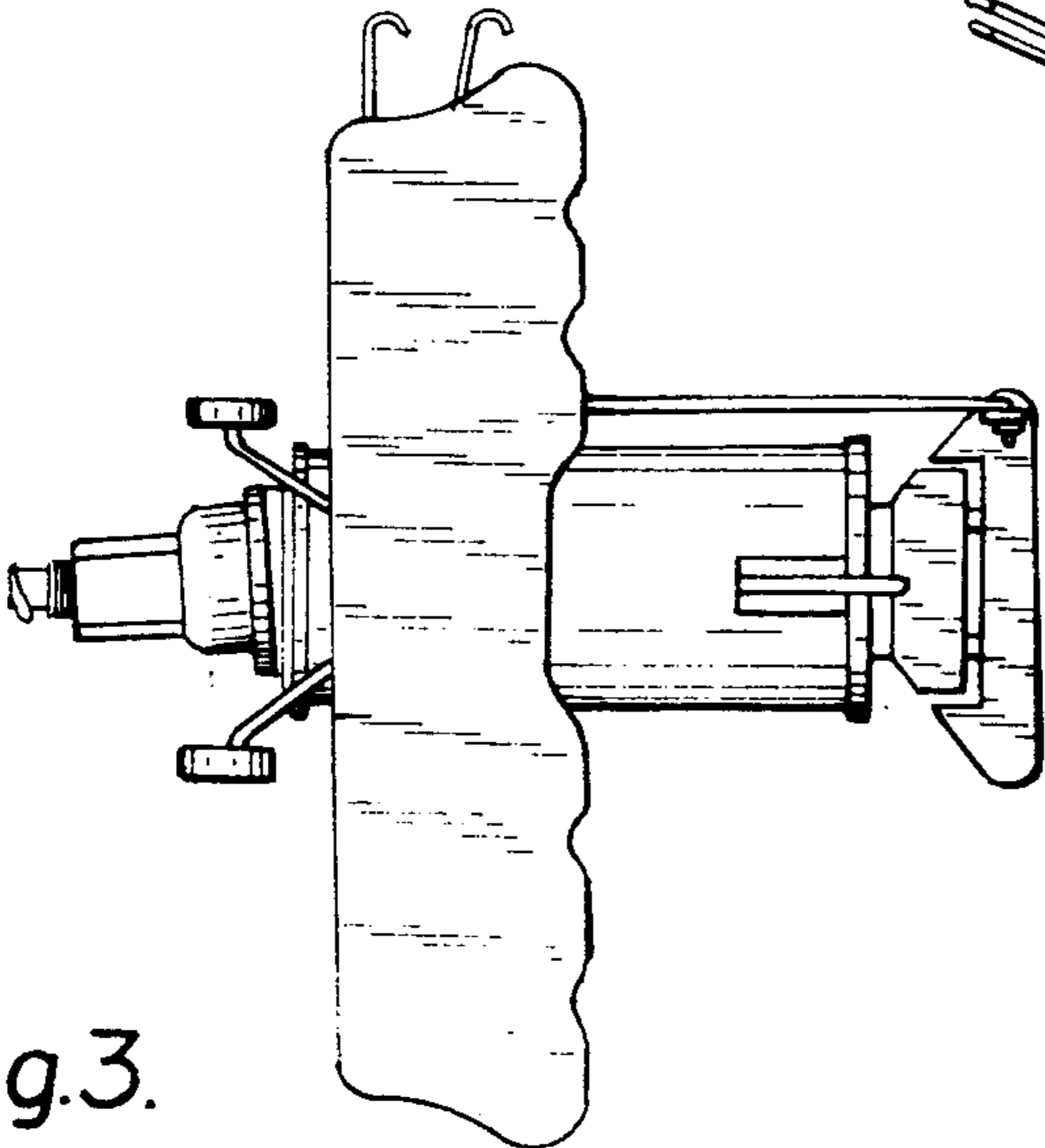

Fig. 3.

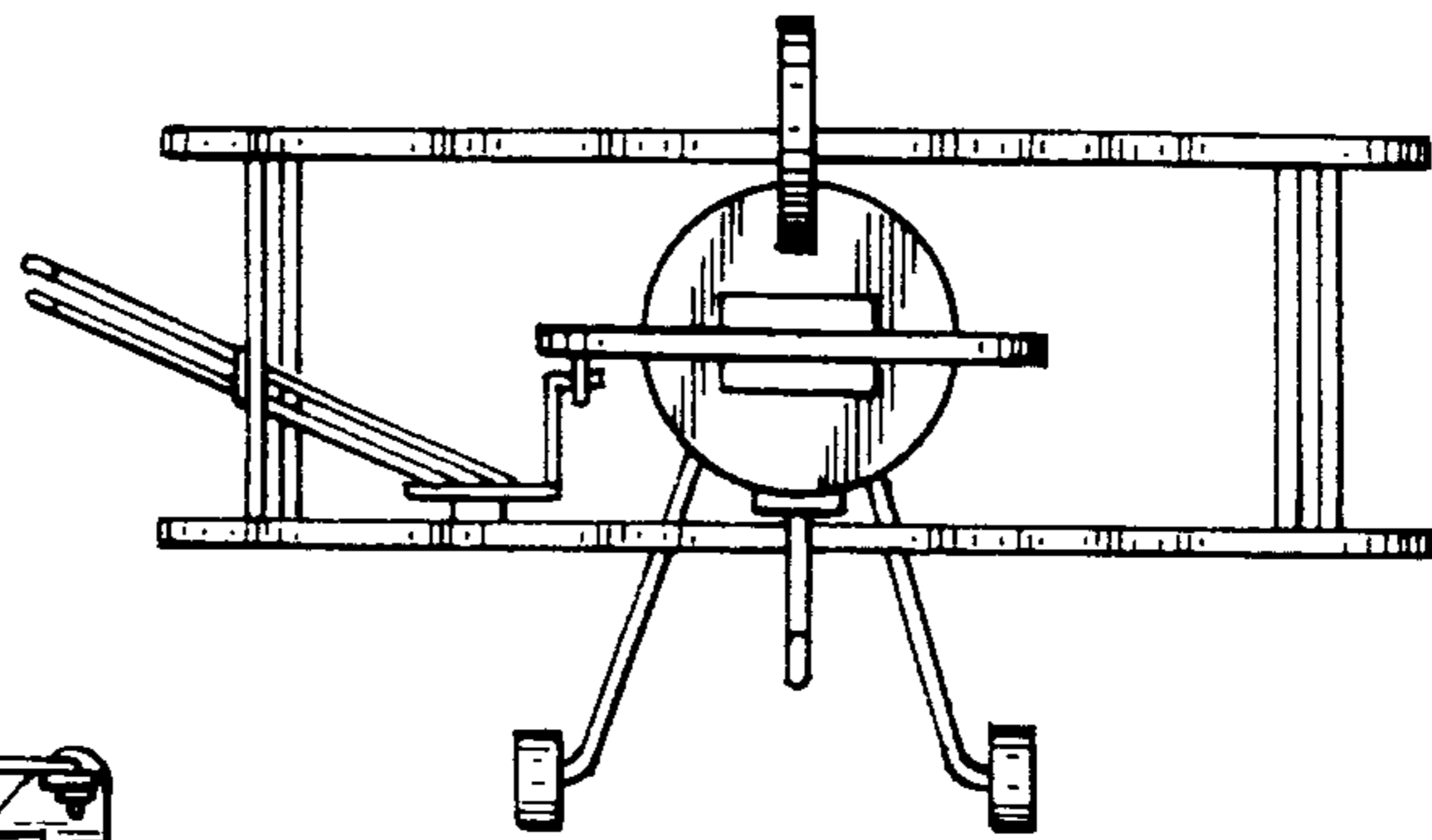

Fig. 6.