

[54] MOTORCYCLE FAIRING

[75] Inventor: John Mockett, Watford, England

[73] Assignee: Yamaha Motor N.V.

[**] Term: 14 Years

[21] Appl. No.: 925,887

[22] Filed: Jul. 18, 1978

[30] Foreign Application Priority Data

Jan. 18, 1978 [XB] Benelux 52434-00

[51] Int. Cl. D12-11

[52] U.S. Cl. D12/182

[58] Field of Search D12/182; 296/78.1

[56] References Cited

U.S. PATENT DOCUMENTS

D. 246,098 10/1977 Muth D12/182

D. 249,257 9/1978 Beaubien et al. D12/182

OTHER PUBLICATIONS

1972 Vetter Catalog, P20, Phantom Fairing, 1968.

Primary Examiner—James M. Gandy

Attorney, Agent, or Firm—Robert E. Wickersham

[57] CLAIM

The ornamental design for a motorcycle fairing, substantially as shown and described.

DESCRIPTION

FIG. 1 is a perspective view of a motorcycle fairing showing my new design, it being understood that the broken lines are for illustrative purposes only;

FIG. 2 is a front elevational view thereof;

FIG. 3 is a side elevational view thereof, the opposite side being a mirror image of the side shown;

FIG. 4 is a rear elevational view thereof;

FIG. 5 is a top plan view thereof; and

FIG. 6 is a bottom plan view thereof.

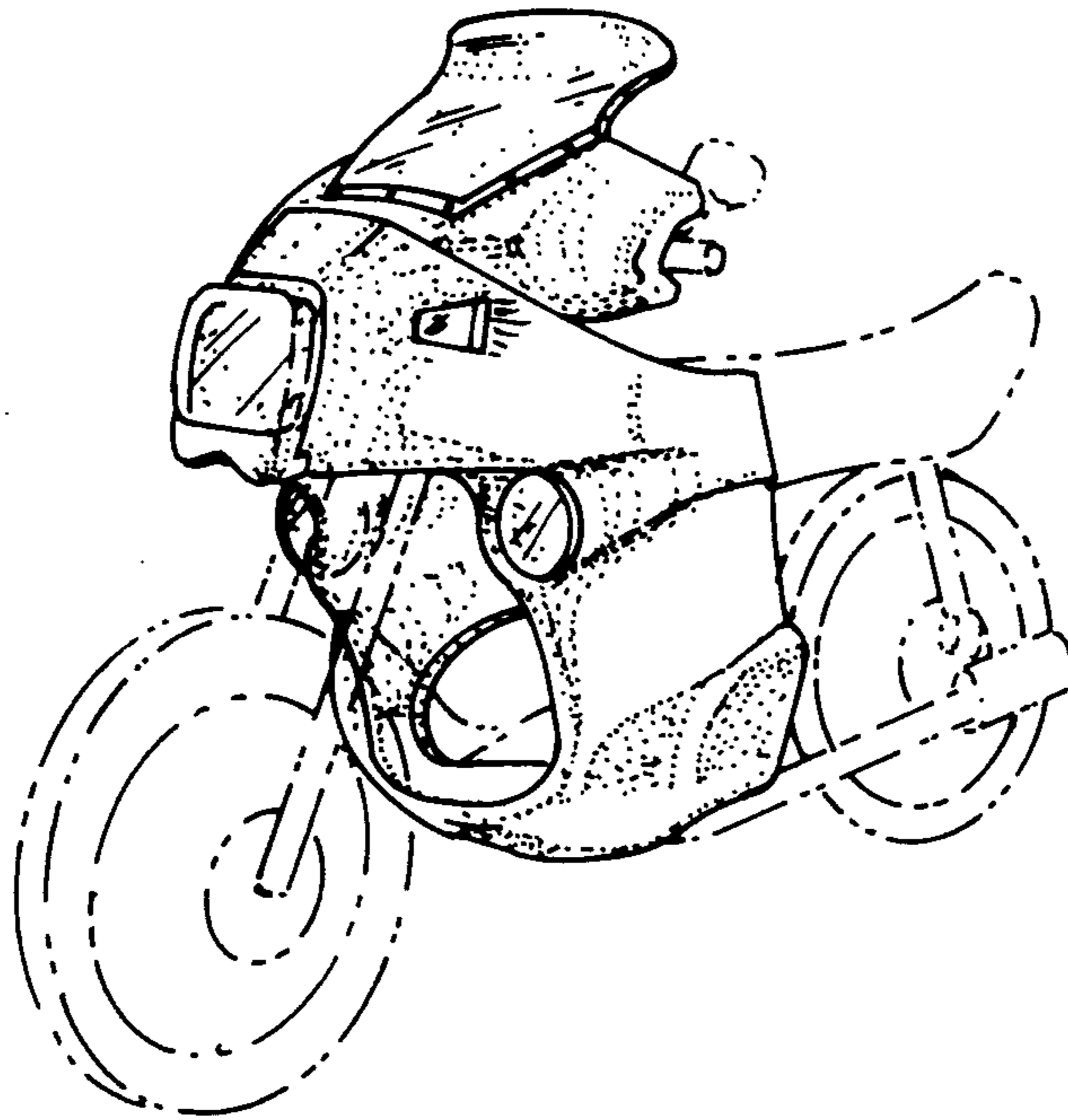

FIG. 1

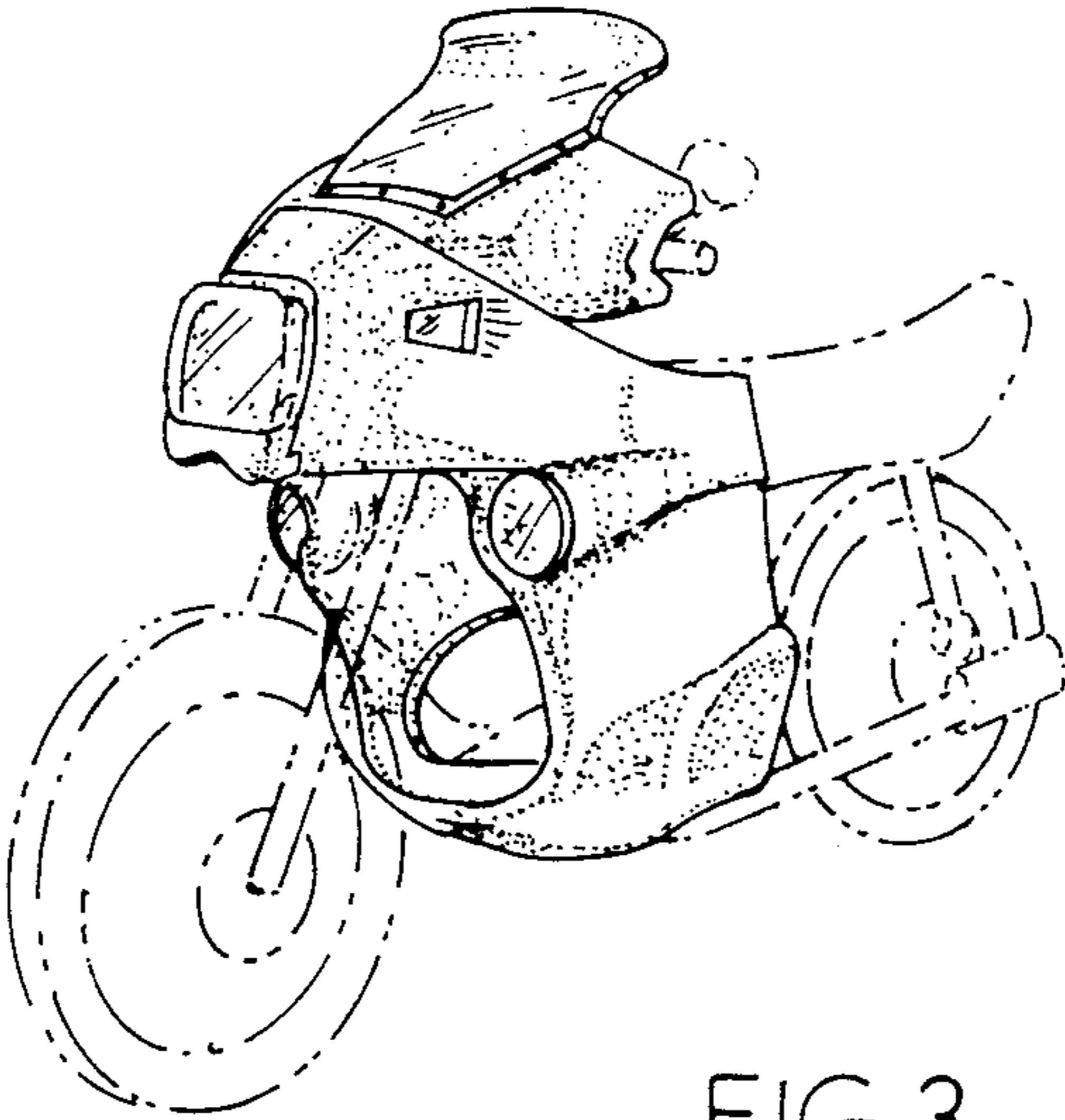

FIG. 3

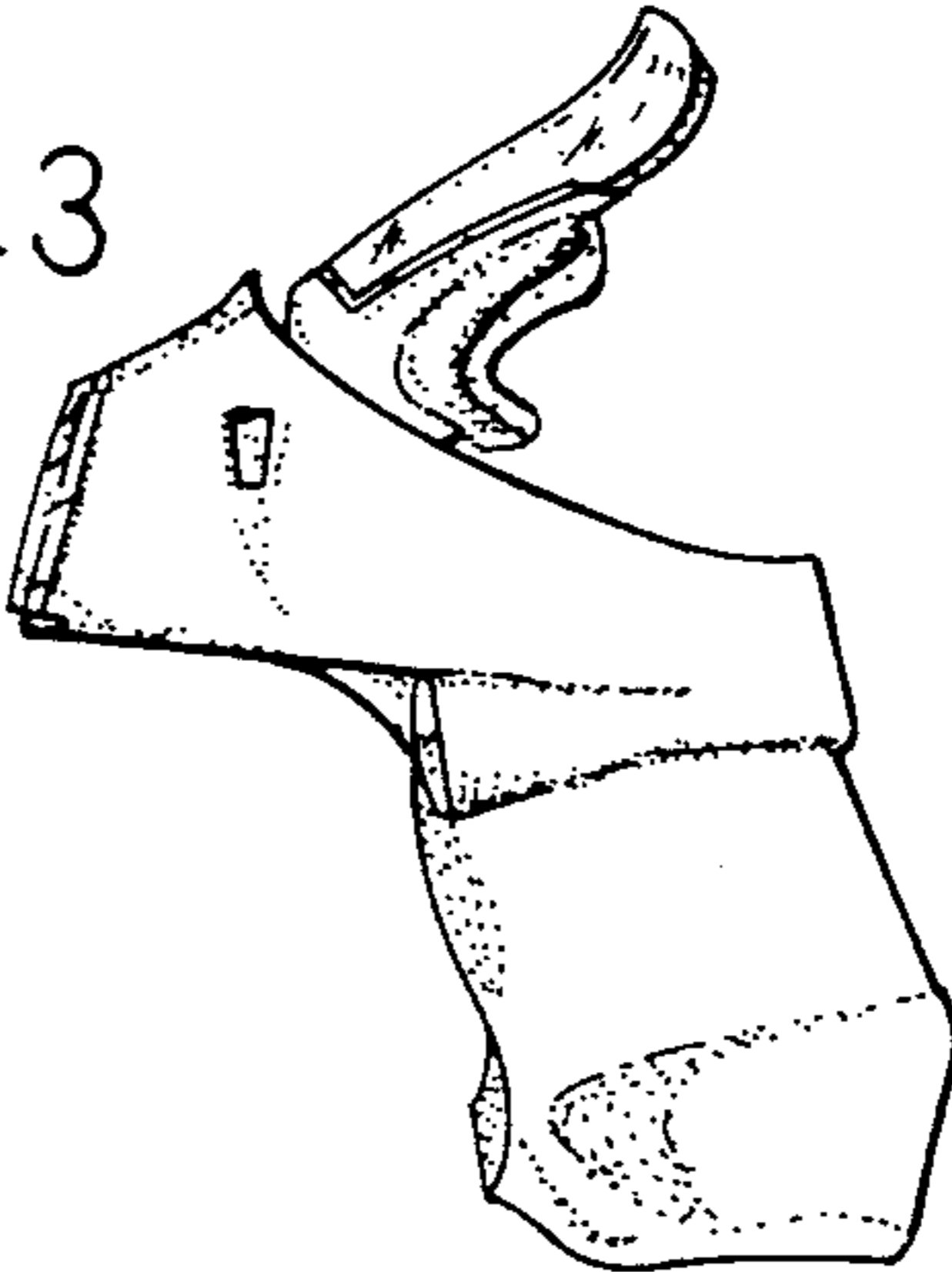

FIG. 2

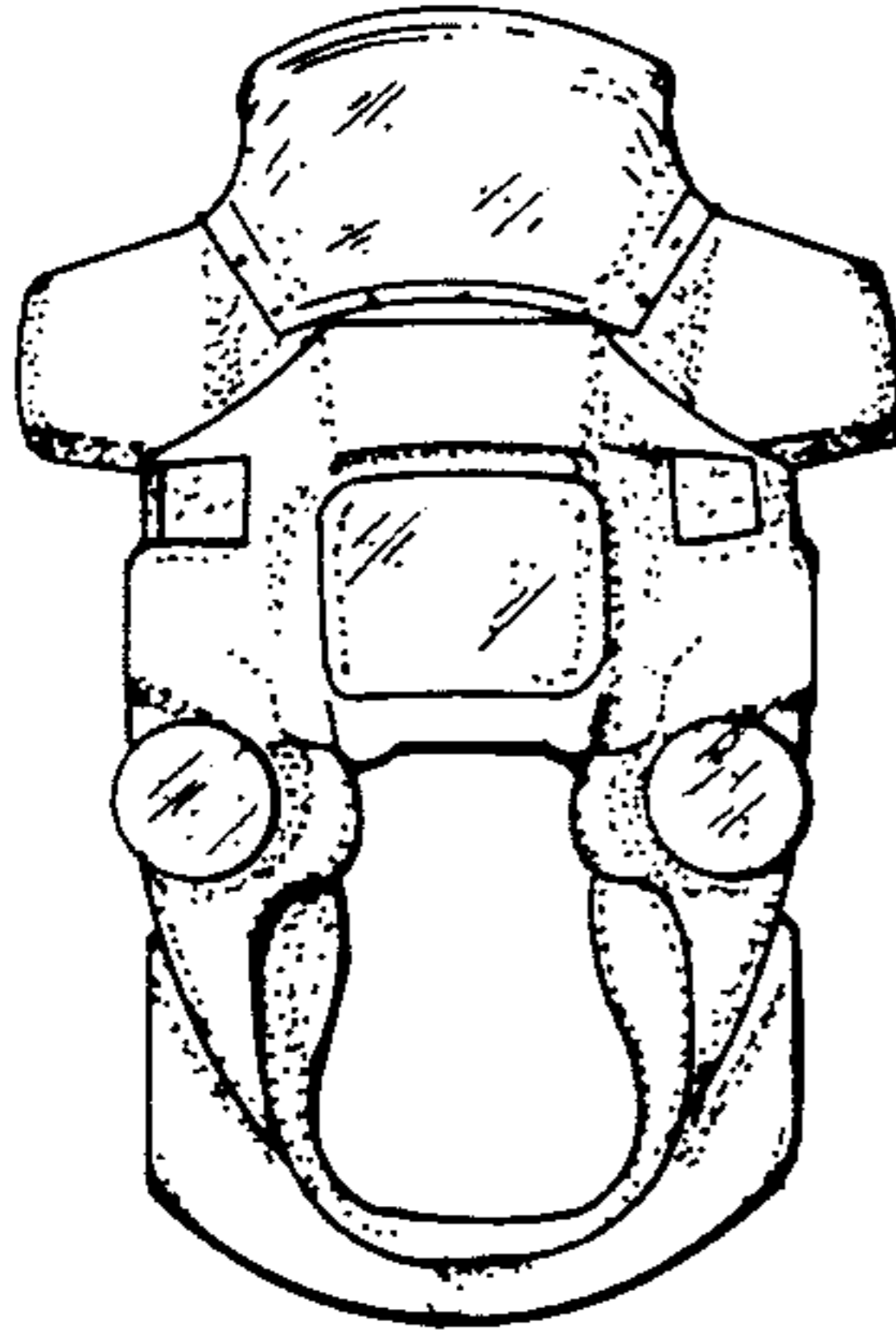

FIG. 5

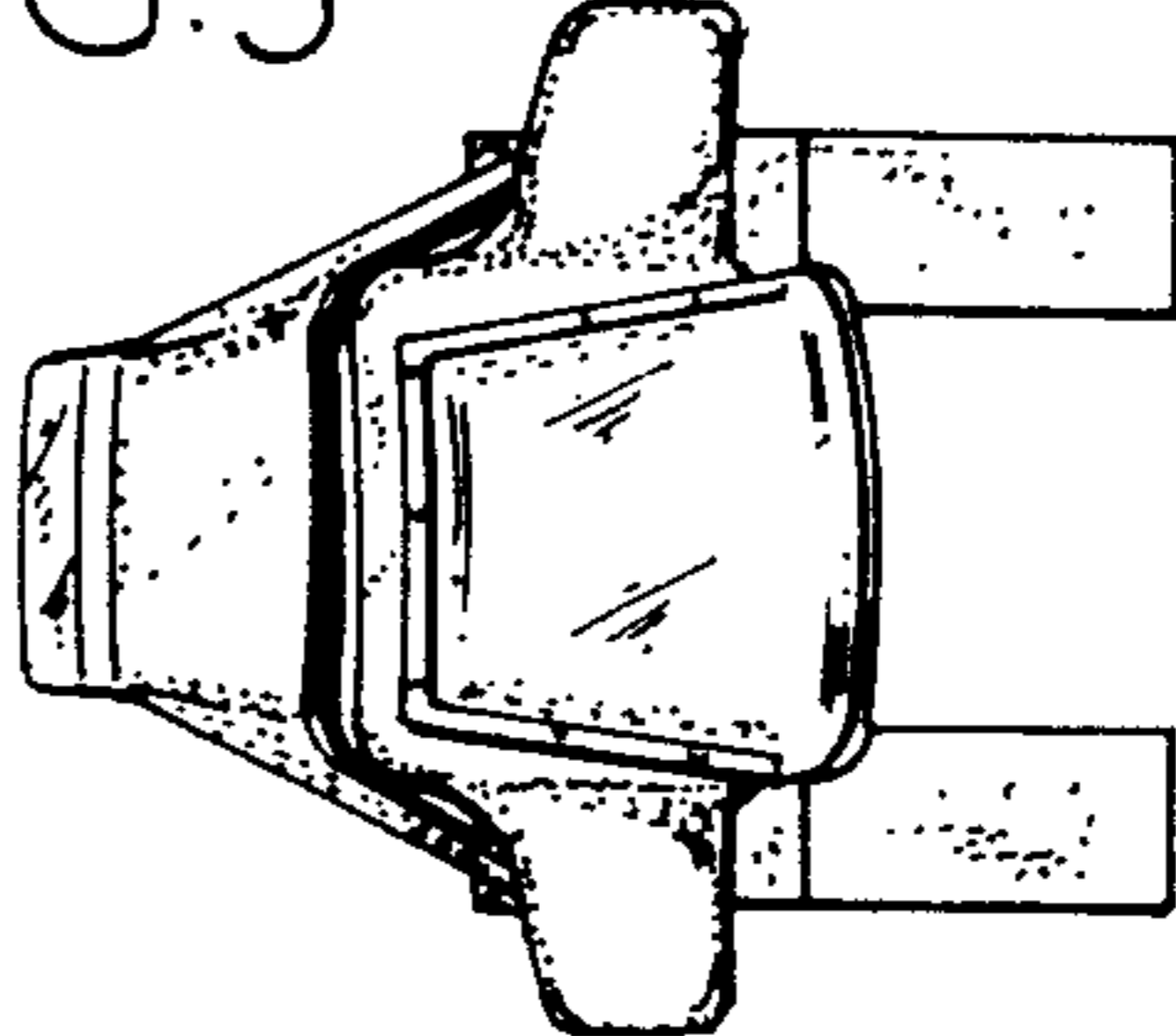

FIG. 4

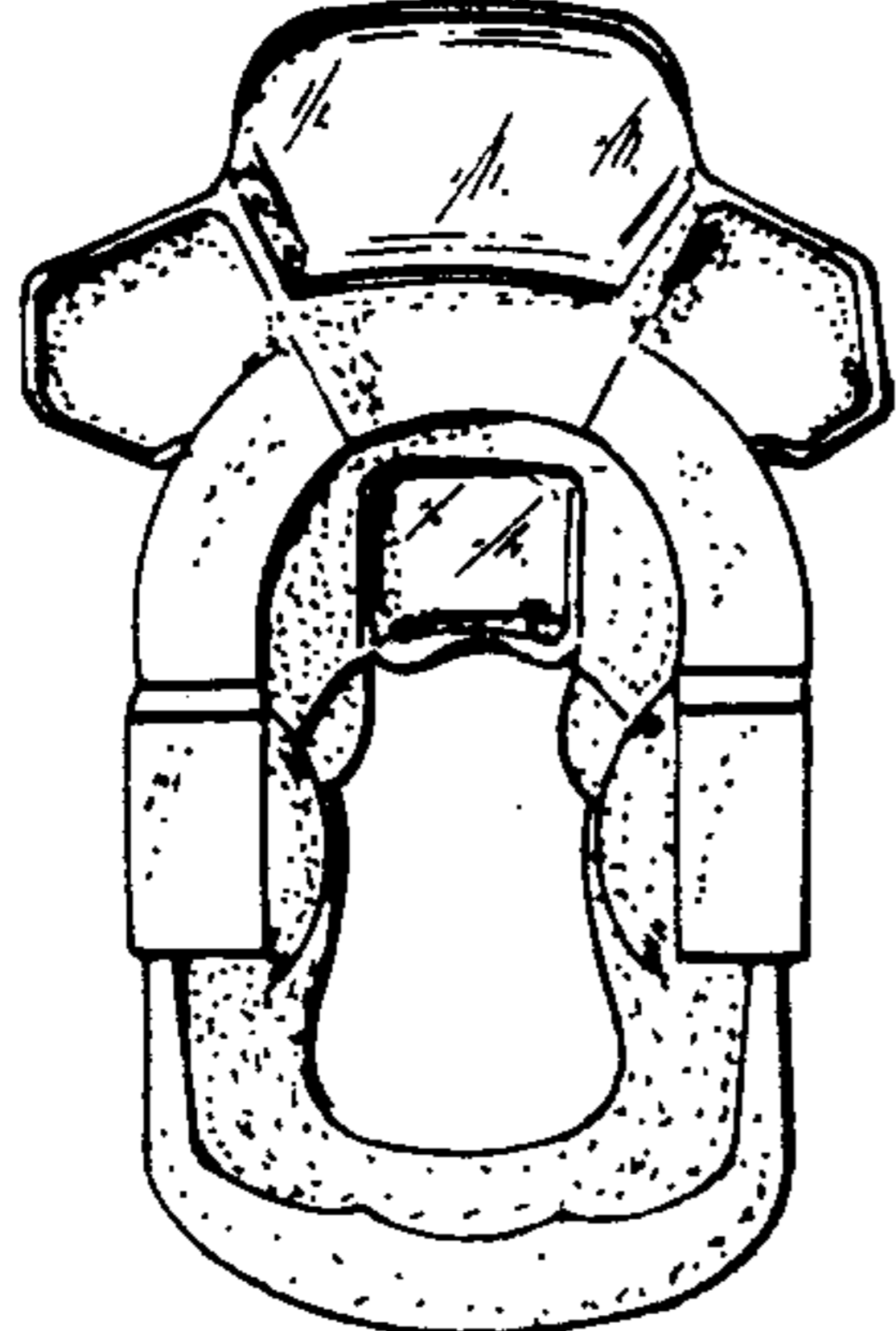

FIG. 6

