

[54] RAILROAD RESTAURANT

[76] Inventor: Gary M. Levin, 940 E. 19 St., Brooklyn, N.Y. 11230

[\*\*] Term: 14 Years

[21] Appl. No.: 928,387

[22] Filed: Jul. 27, 1978

[51] Int. Cl. .... D25-03

[52] U.S. Cl. .... D25/11; D25/17; D25/22; D25/23; D25/33; D25/52

[58] Field of Search .... D25/1, 3, 7, 11, 52, D25/17, 22, 23, 24, 25, 26, 33; 52/73; D12/101, 102, 103

[56] References Cited

U.S. PATENT DOCUMENTS

D. 115,683	7/1939	Bemis .....	D25/11
D. 227,356	6/1973	Winter .....	D25/11
3,673,749	7/1972	Allen .....	52/73
4,098,036	7/1978	Spöler .....	52/73 X

OTHER PUBLICATIONS

Interiors, Oct. 1976, p. 88, Victoria Station Restaurant. Progressive Architecture, Apr. 1977, p. 112, Building at lower right.

Primary Examiner—A. Hugo Word  
Attorney, Agent, or Firm—Howard Alan Taishoff

[57] CLAIM

The ornamental design for a railroad restaurant, as shown and described.

DESCRIPTION

FIG. 1 is a front perspective view of the right side of a railroad restaurant according to my new design; FIG. 2 is a front perspective view of the left side of the railroad restaurant of FIG. 1; FIG. 3 is a top view of the railroad restaurant of FIG. 1; FIG. 4 is an elevational view of the right side shown in FIG. 1; FIG. 5 is an elevational view of the left side shown in FIG. 2; FIG. 6 is an elevational view of the front shown in FIG. 1; FIG. 7 is an elevational view of the rear of the railroad restaurant of FIG. 1.

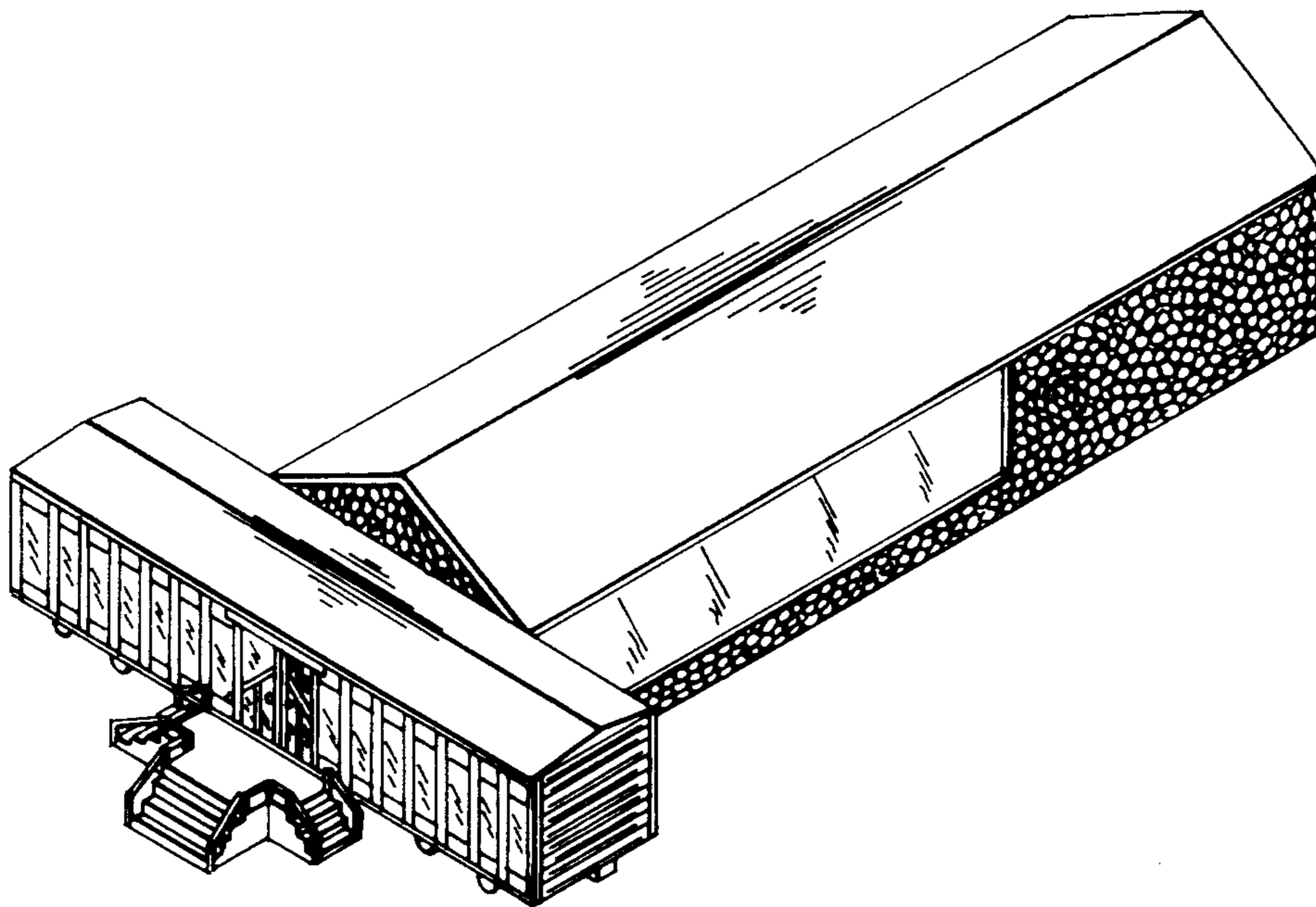

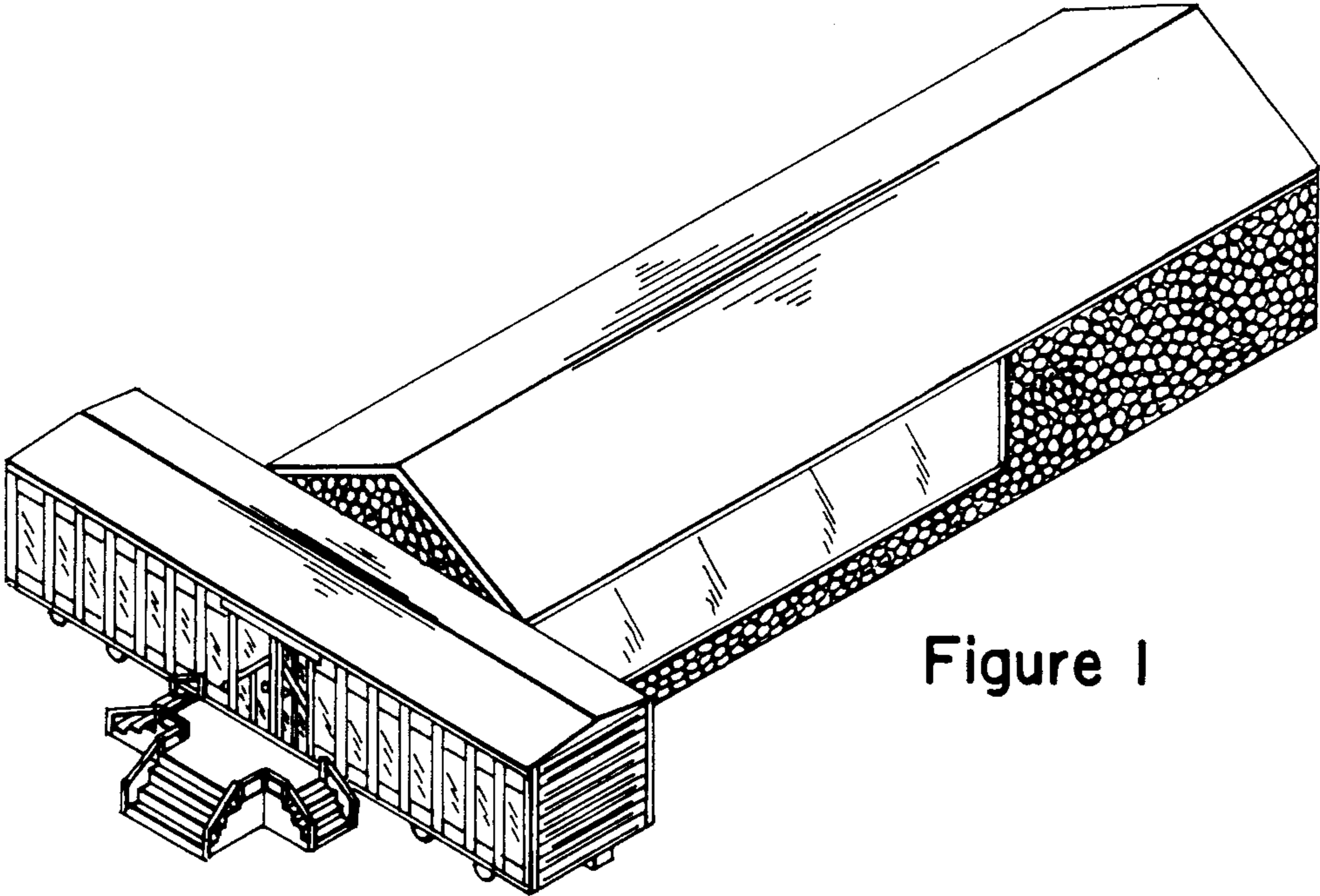

Figure 1

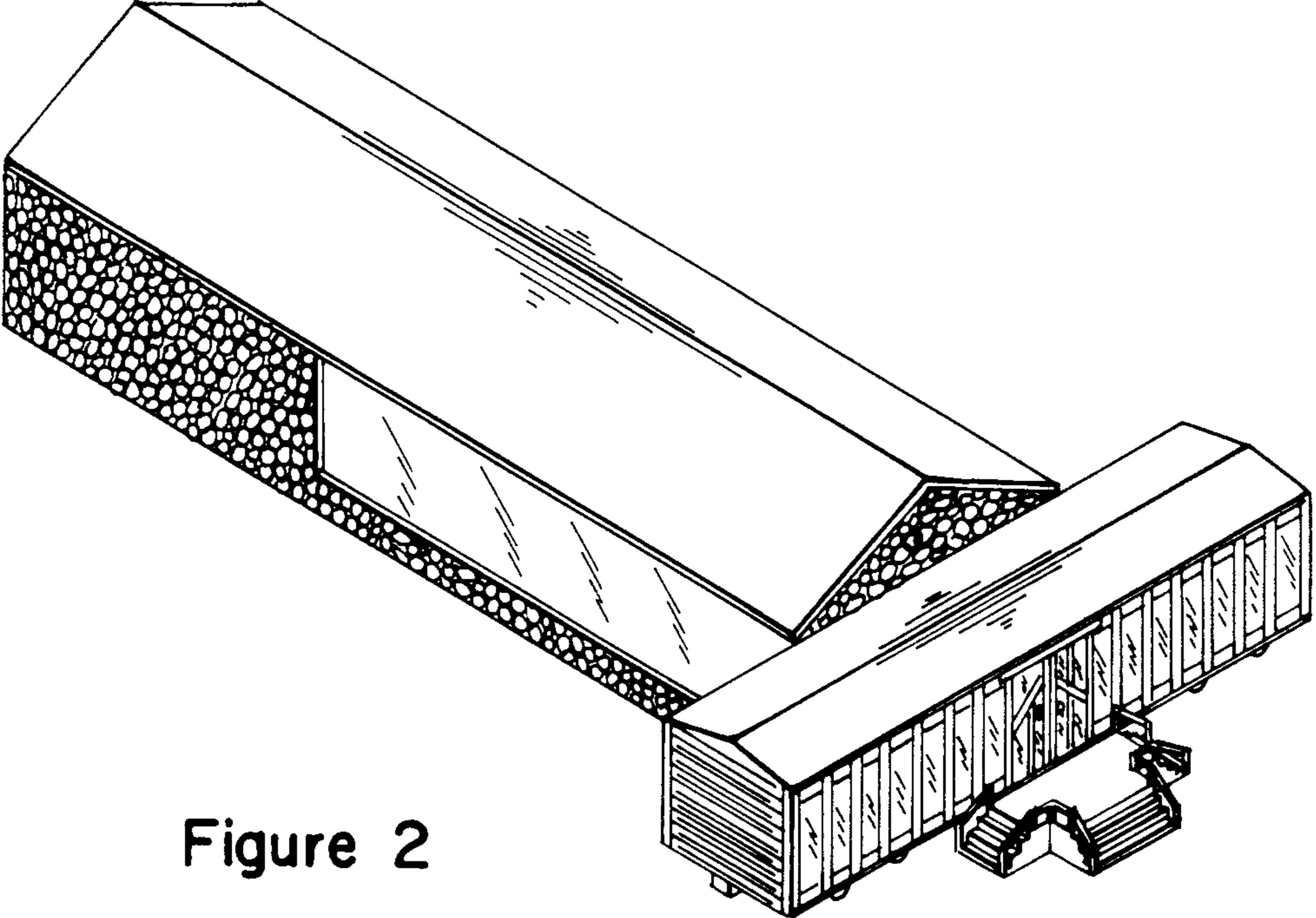

Figure 2

