

[54] AUTOMOBILE

[76] Inventor: **Leslie N. Dunham**, 234 Division St., Boonton, N.J. 07005

[**] Term: **14 Years**

[21] Appl. No.: **961,229**

[22] Filed: **Nov. 10, 1978**

[51] Int. Cl. **D12-08**

[52] U.S. Cl. **D12/92**

[58] Field of Search **D12/91, 92; D21/78, D21/131, 137; 296/185**

[56] **References Cited**

U.S. PATENT DOCUMENTS

D. 242,912 1/1977 Tedesco **D12/92**

OTHER PUBLICATIONS

1972 Lincoln-Mercury Brochure, p. 2, Continental Mark IV.

Autocar, 11/12/77, p. 20, 1977 Cobra Replica, bottom of page.

Autocar, 5/21/77, p. 1, Jaguar XJ-S, bottom right side of page.

Primary Examiner—James M. Gandy

Attorney, Agent, or Firm—Roy C. Hopgood

[57]

CLAIM

The ornamental design for an automobile, as shown and described.

DESCRIPTION

FIG. 1 is a front perspective view of an automobile showing my new design;

FIG. 2 is a rear perspective view thereof;

FIG. 3 is a top plan view thereof; and

FIG. 4 is a right side perspective view thereof, the left side being substantially a mirror image of the right side shown.

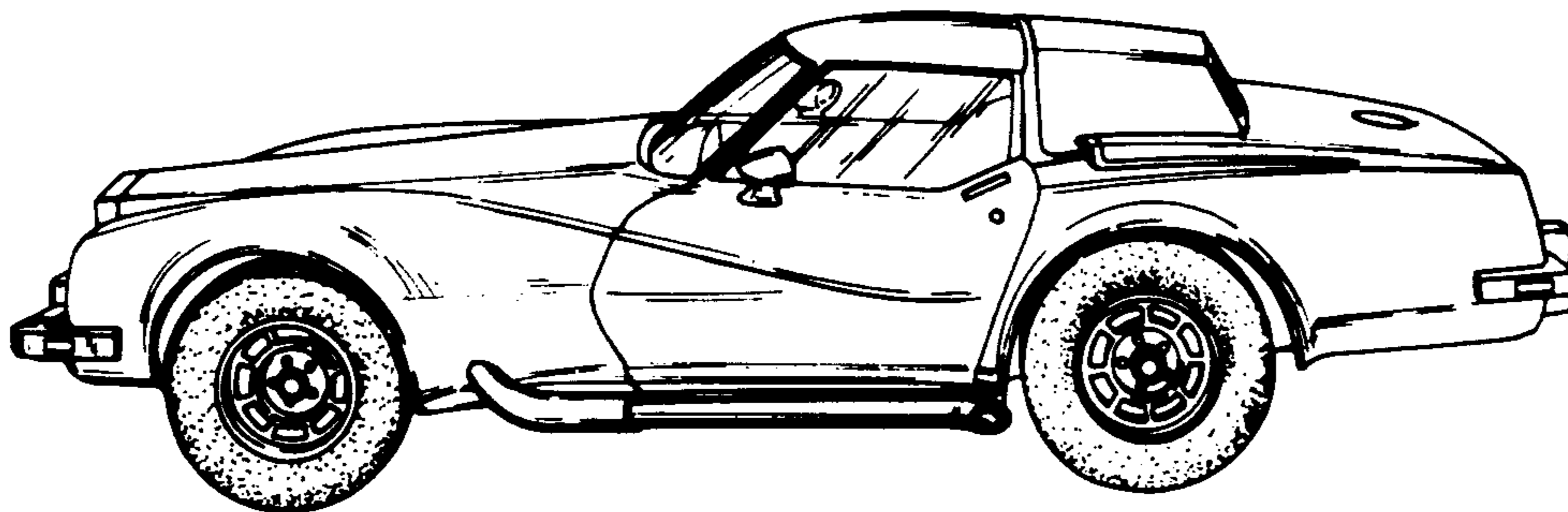

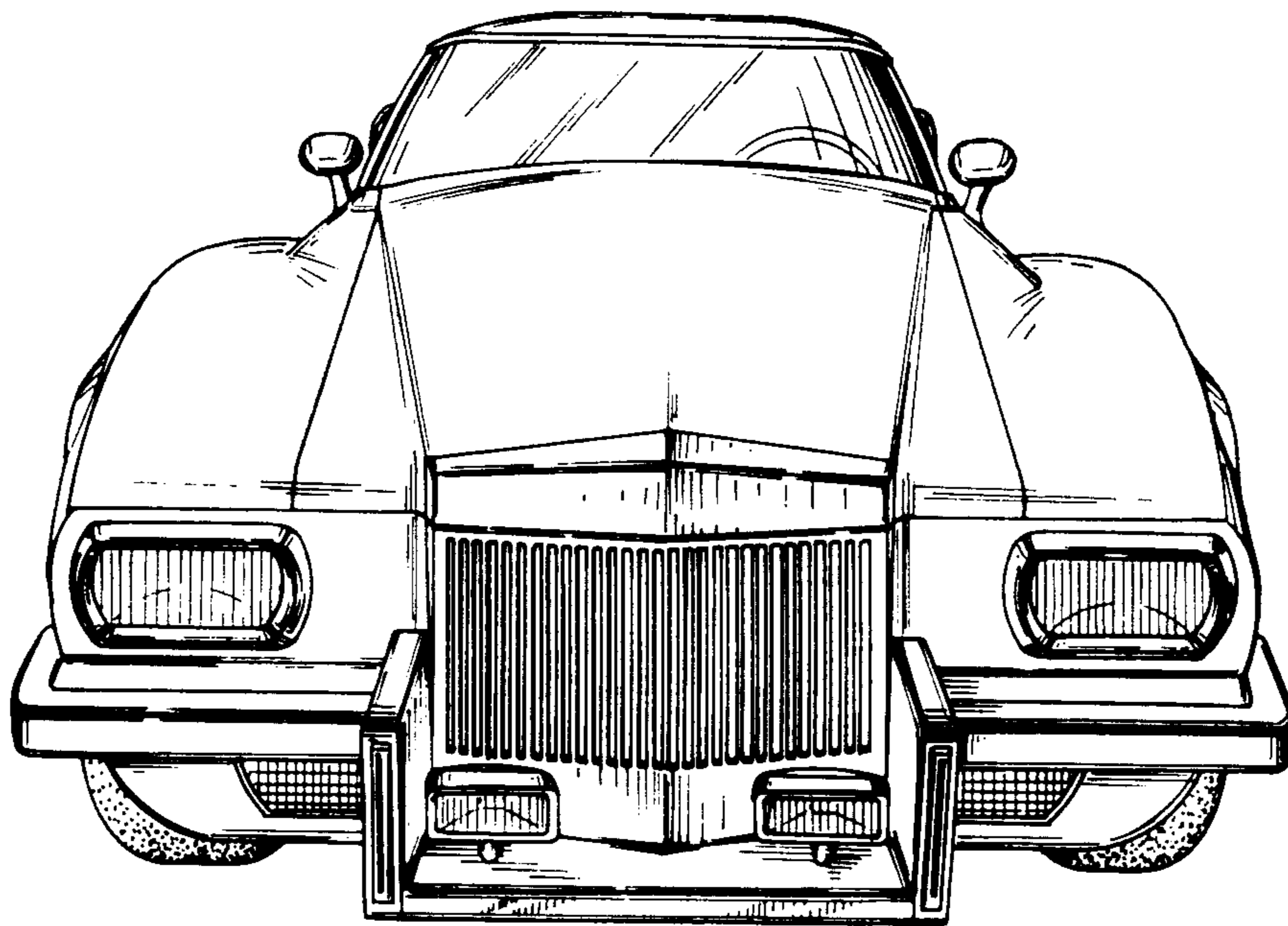

FIG. 1

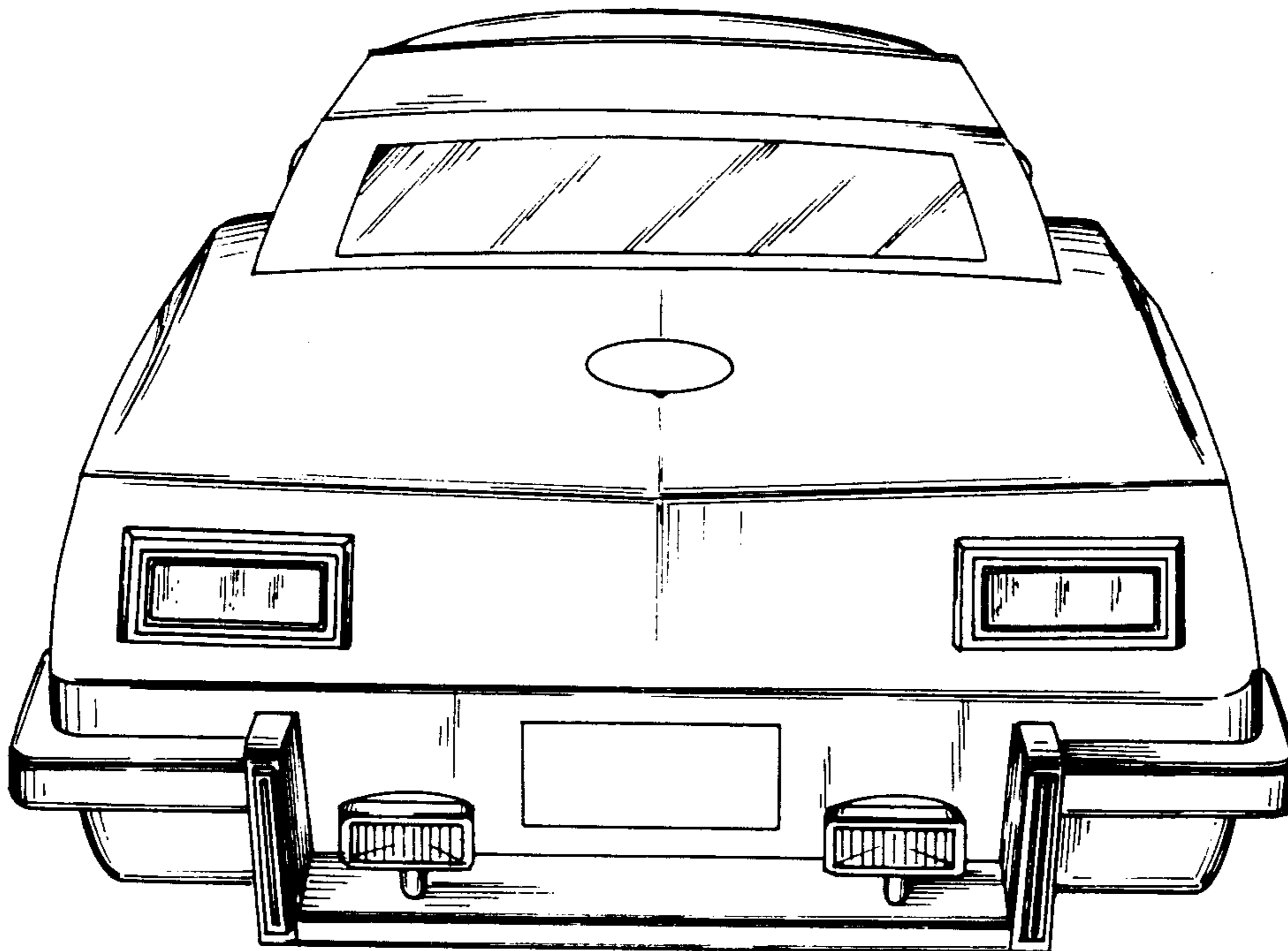

FIG. 2

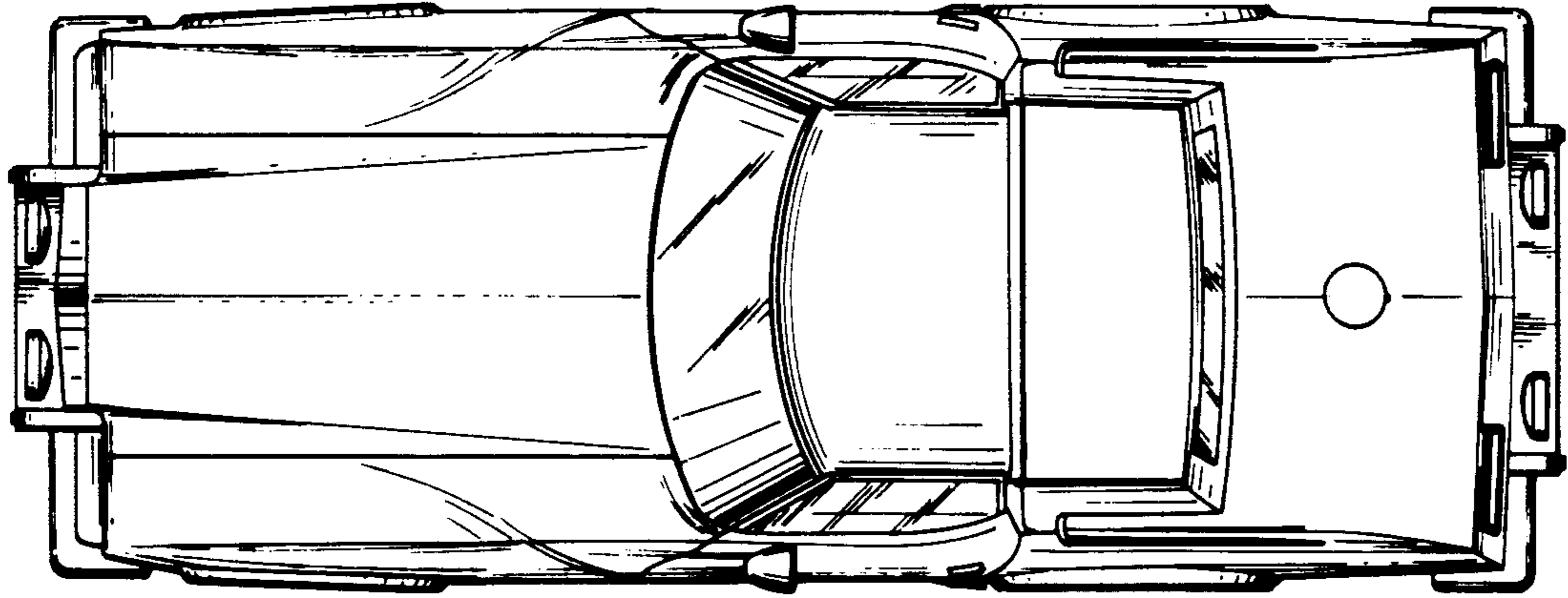

FIG. 3

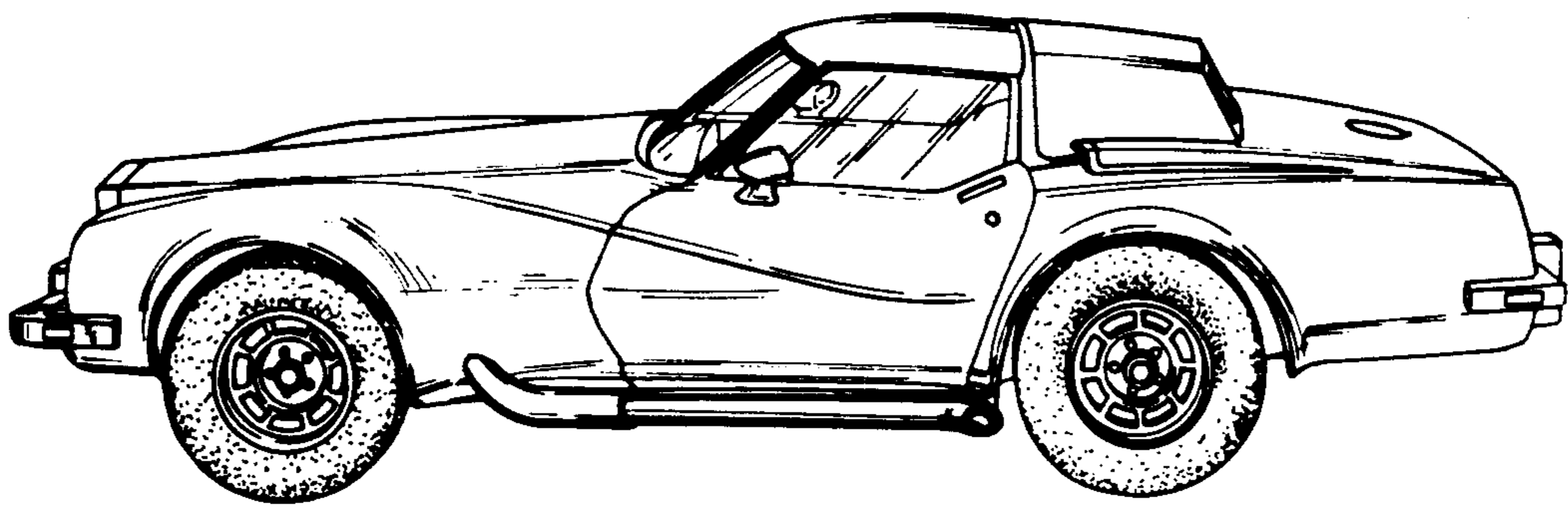

FIG. 4