

[54] WHEEL FOR MOTORCYCLE

[75] Inventor: **Tatsuo Horikoshi**, Tokyo, Japan

[73] Assignee: **Yamaha Hatsudoki Kabushiki Kaisha**, Japan

[**] Term: **14 Years**

[21] Appl. No.: **84,057**

[22] Filed: **Oct. 11, 1979**

[30] **Foreign Application Priority Data**

Apr. 14, 1979 [JP] Japan 54-15193

[51] Int. Cl. **D12-16**

[52] U.S. Cl. **D12/205**

[58] Field of Search D12/205, 206, 209, 211; 301/63 R, 64 R, 64 SD, 65, 66, 73, 54, 58

[56] **References Cited**

U.S. PATENT DOCUMENTS

D. 235,431	6/1975	Scott	D12/205
D. 239,863	5/1976	Kitson	D12/205
1,826,815	10/1931	O'Connor	D12/205

OTHER PUBLICATIONS

Cycle World, 6/76, P.66, Lester Cast Alloy Wheels, top left side of page.

Primary Examiner—James M. Gandy
Attorney, Agent, or Firm—Ostrolenk, Faber, Gerb & Soffen

[57] **CLAIM**

The ornamental design for a wheel for motorcycle, as shown.

DESCRIPTION

FIG. 1 is a front elevational view of a wheel for a motorcycle showing my new design; FIG. 2 is a side elevational view thereof; and FIG. 3 is a cross-sectional view thereof, along the line 3—3 in FIG. 1.

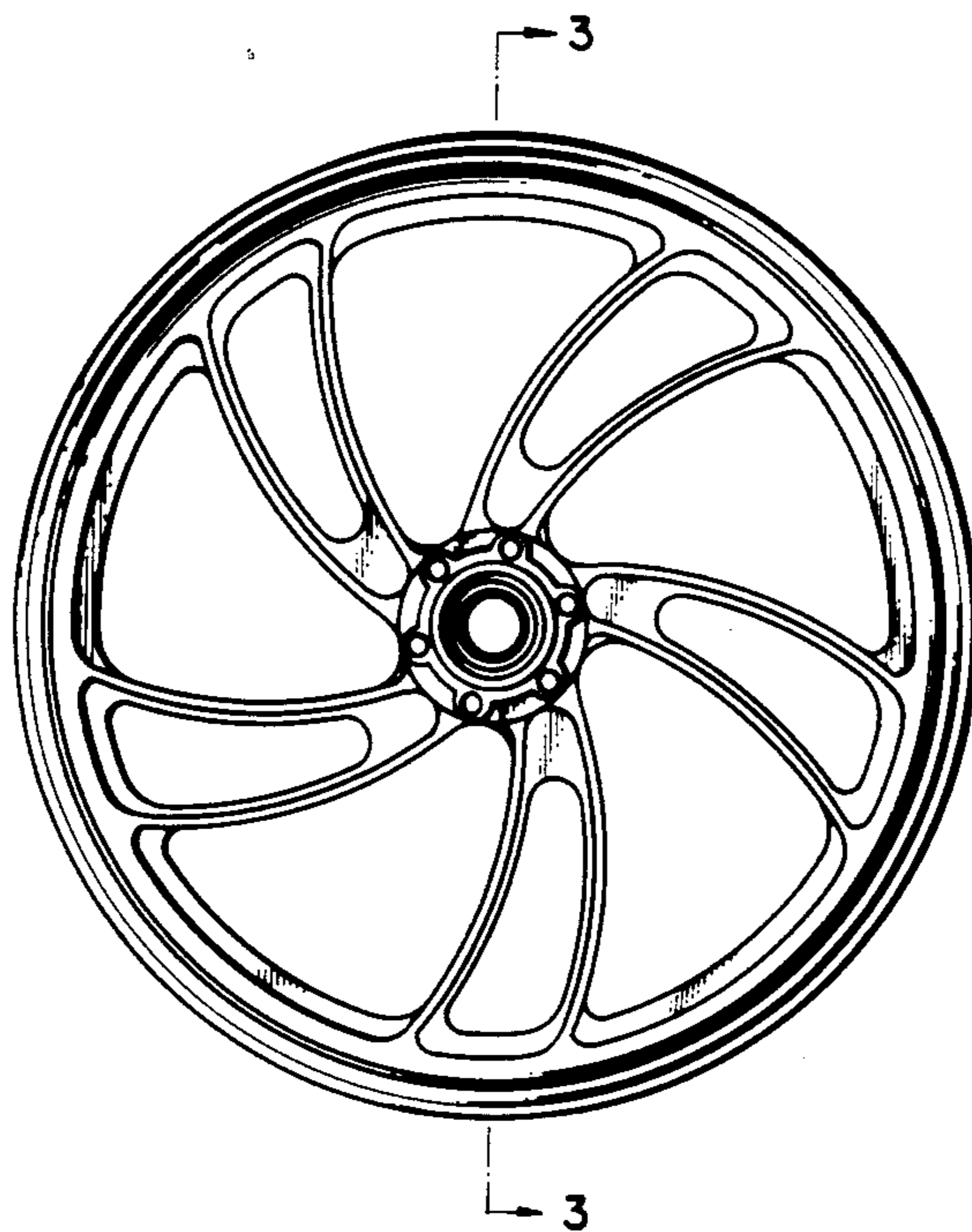

FIG.1

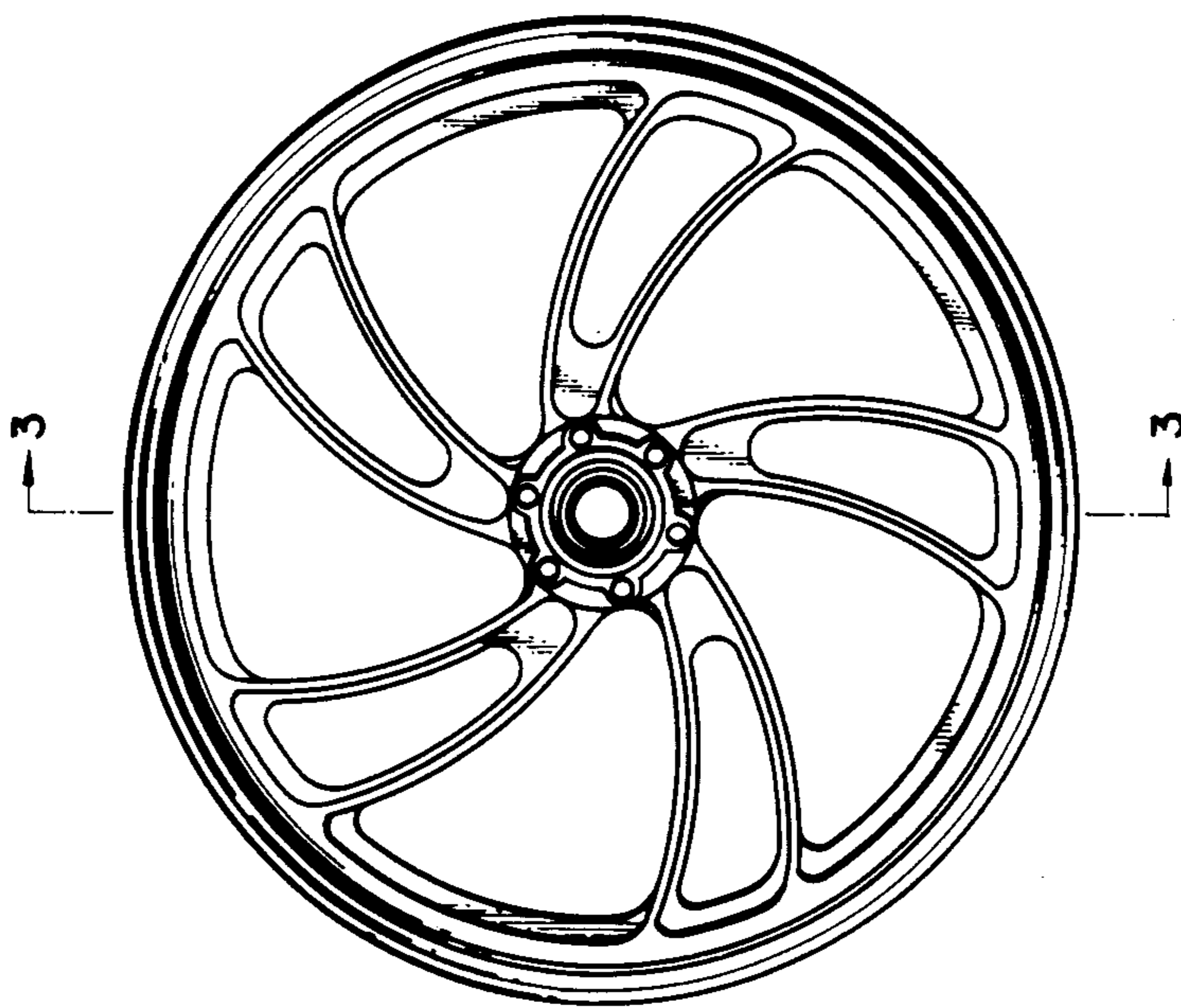

FIG.2

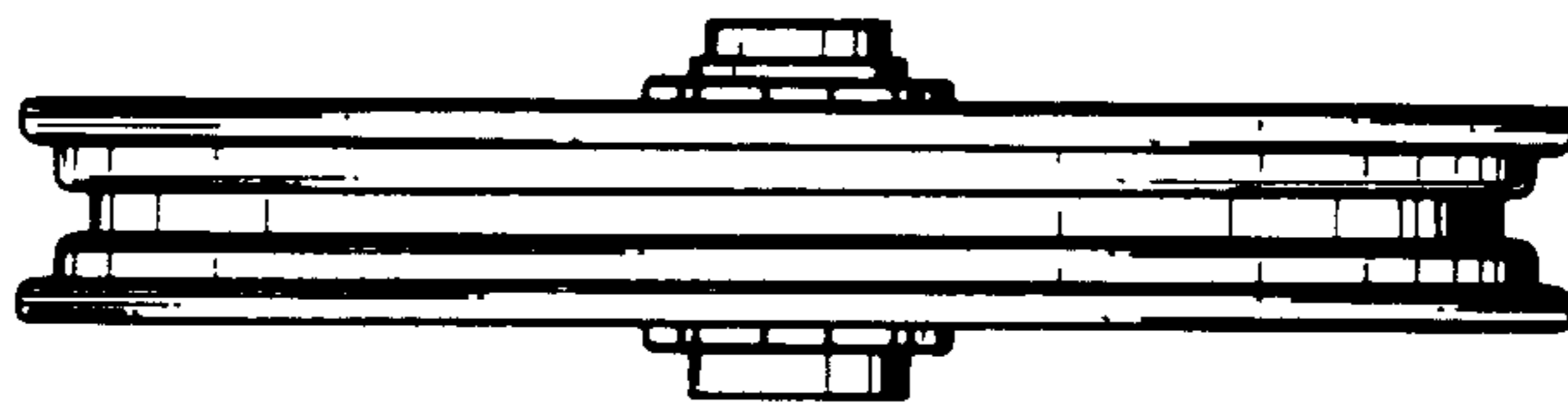

FIG.3

