

[54] VEHICLE WHEEL

[56]

References Cited

U.S. PATENT DOCUMENTS

D. 244,845	6/1977	Woodward	D12/211
D. 247,808	5/1978	Woodward	D12/211
2,670,995	3/1954	Lyon	D12/209

Primary Examiner—James M. Gandy

[57]

CLAIM

The ornamental design for a vehicle wheel, as shown and described.

DESCRIPTION

FIG. 1 is a front elevational view of a vehicle wheel; FIG. 2 is a sectional view taken generally along the plane indicated by line 2—2 of FIG. 1; and FIG. 3 is a fragmentary perspective view thereof, it being understood that a portion of the wheel has been omitted for convenience of illustration.

[76] Inventor: David S. McIntosh, 30187 Pierce, Southfield, Mich. 48076

[**] Term: 7 Years

[21] Appl. No.: 42,065

[22] Filed: May 24, 1979

[51] Int. Cl. D12—16

[52] U.S. Cl. D12/211; D12/212

[58] Field of Search D12/204, 206, 209—212; 301/63 R, 64 R, 64 SD, 65, 66

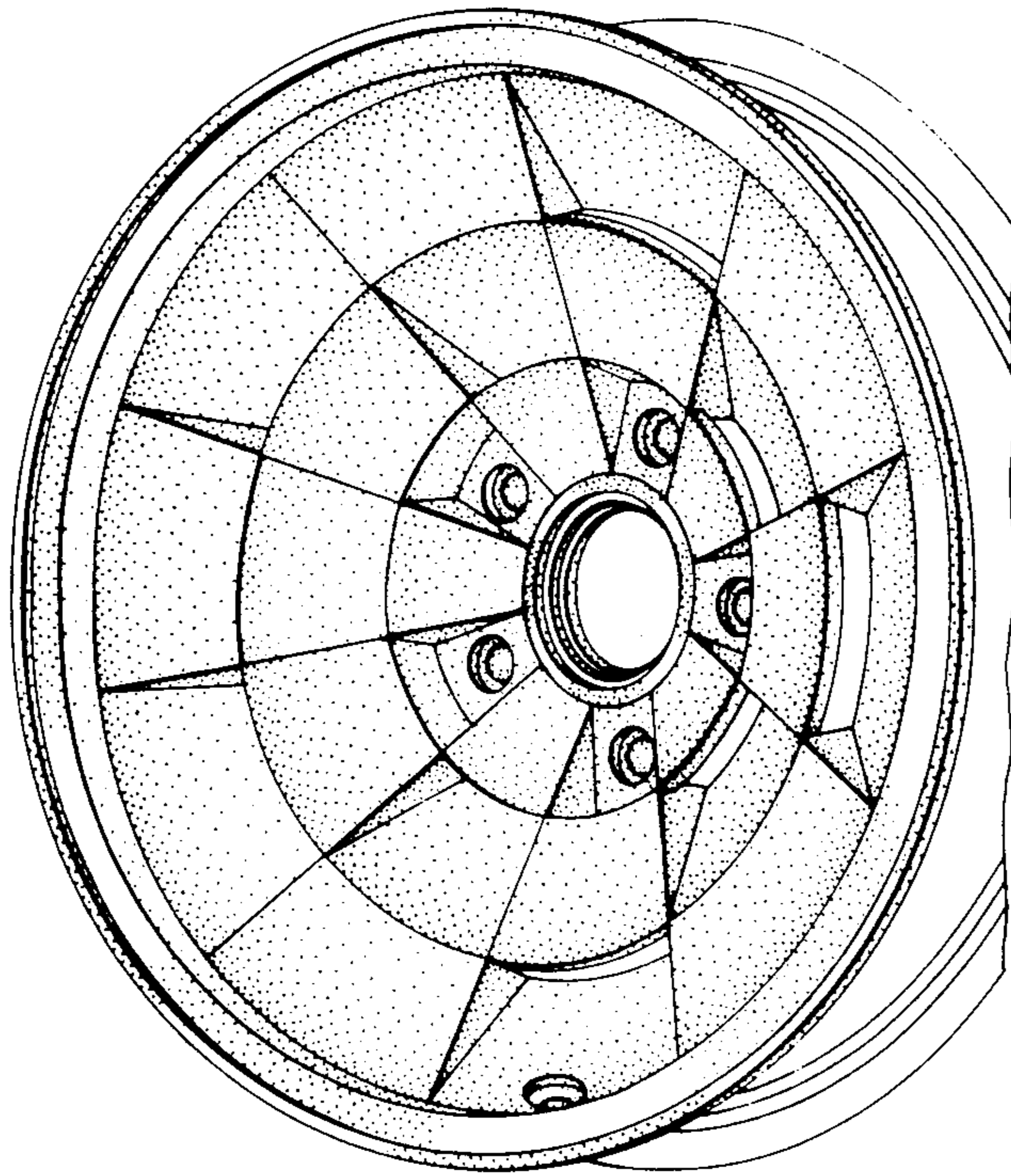

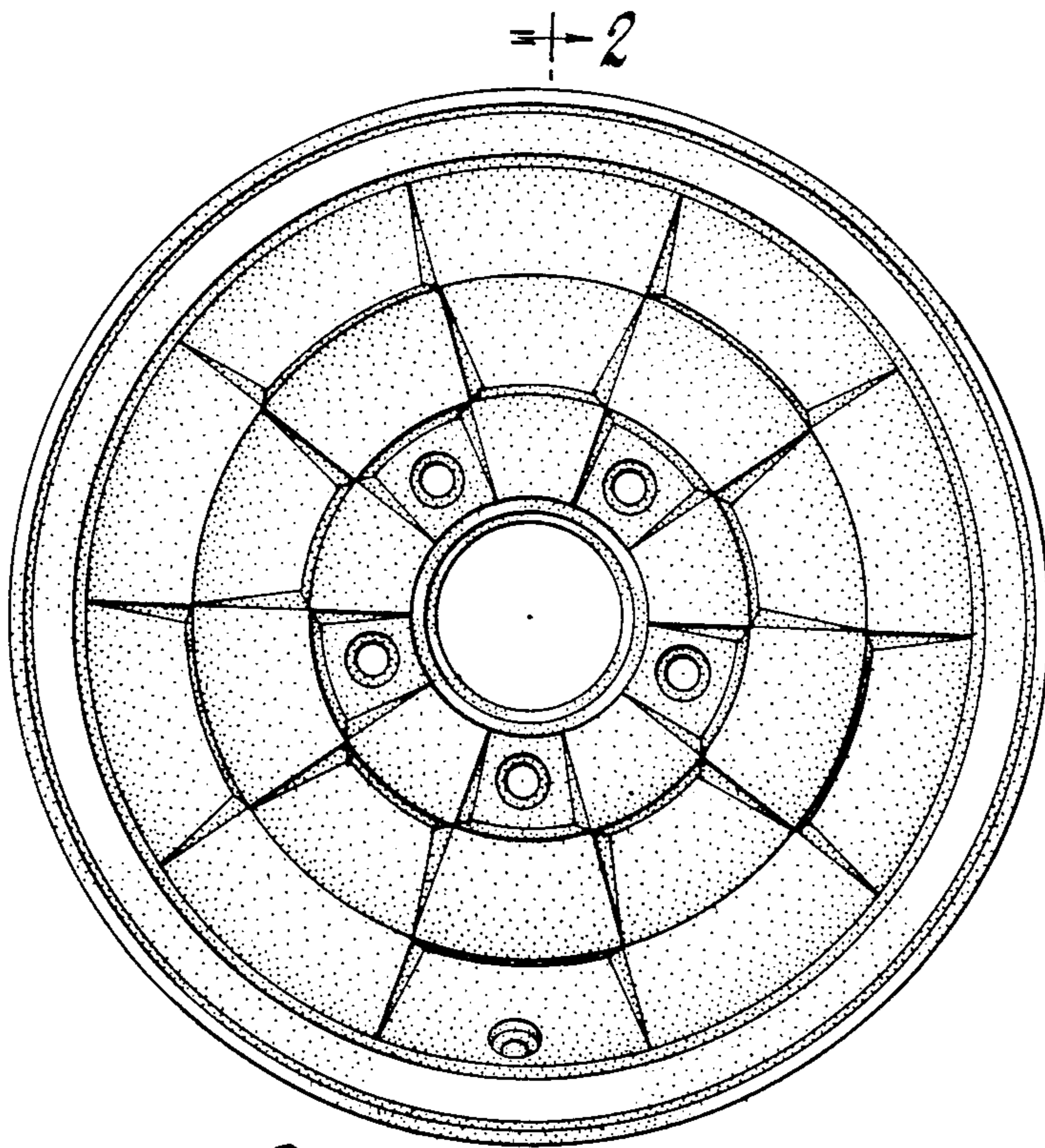

Fig. 1 =+2

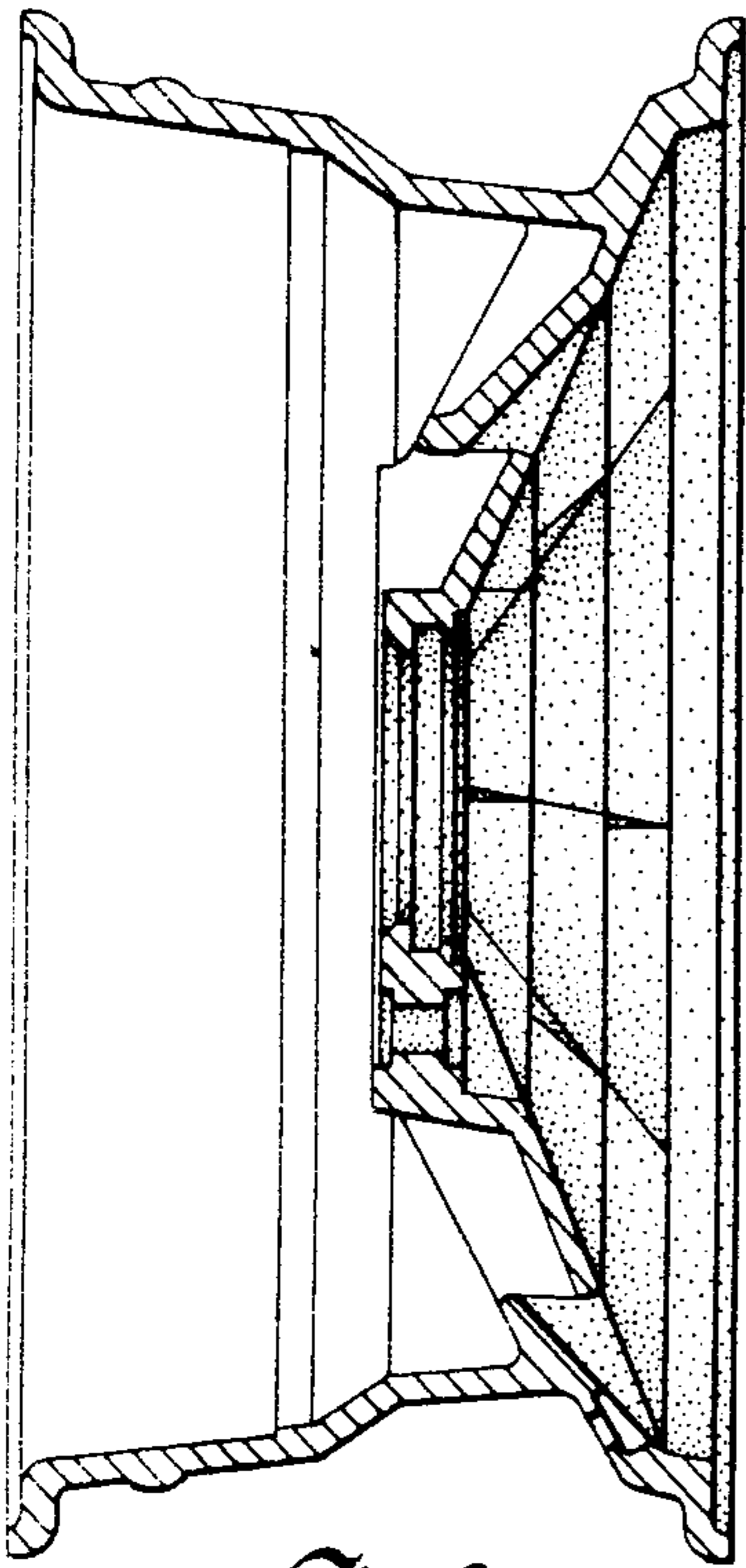

Fig. 2

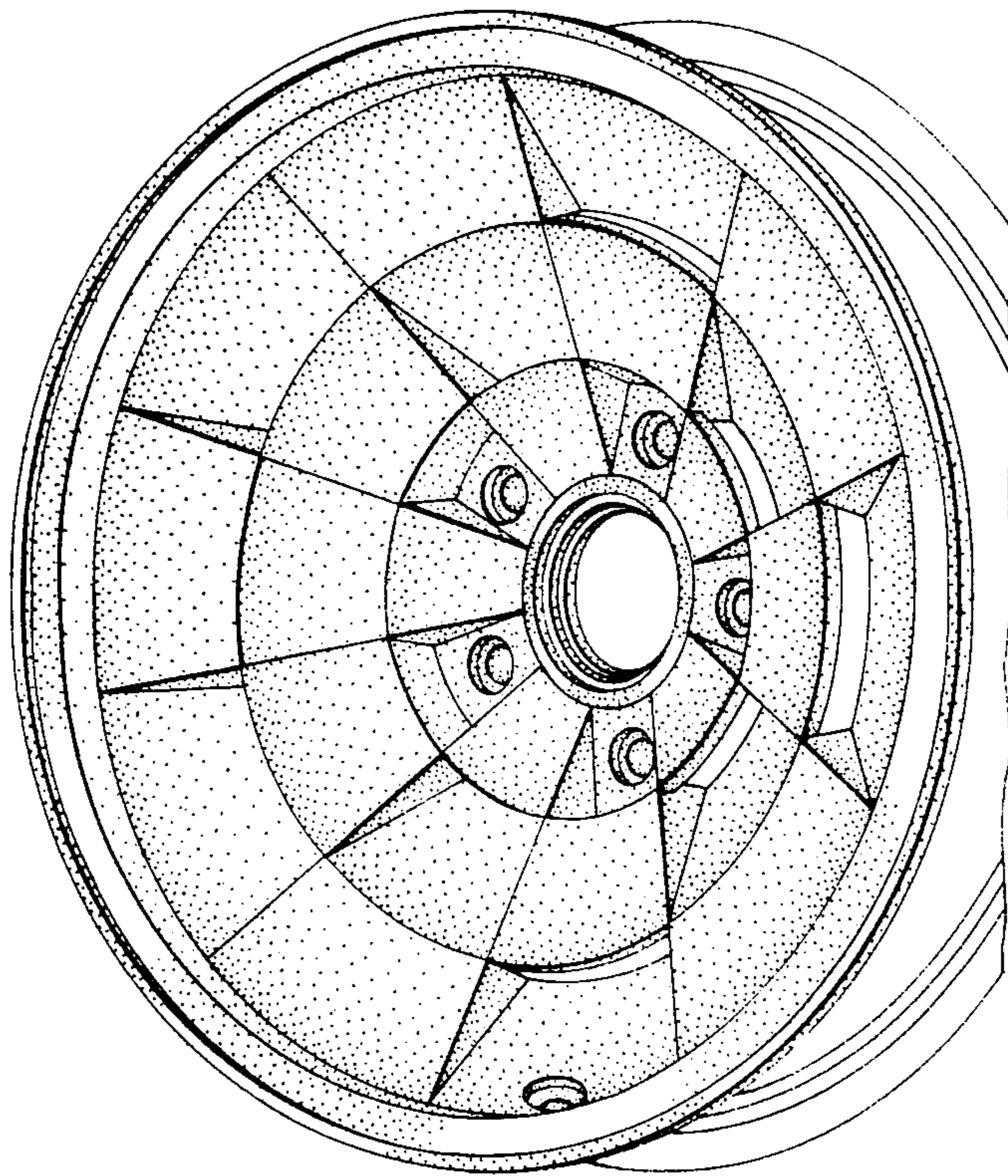

Fig. 3