

[54] TOY VEHICLE

[75] Inventor: Goro Imura, Tateishi, Japan

[73] Assignee: Tomy Kogyo Co., Inc., Tokyo, Japan

[**] Term: 14 Years

[21] Appl. No.: 958,946

[22] Filed: Nov. 8, 1978

[30] Foreign Application Priority Data

Jun. 10, 1978 [JP] Japan 53-24238

[51] Int. Cl. D21-01

[52] U.S. Cl. D21/87; D21/129

[58] Field of Search D21/76, 78, 79, 80, D21/129; 280/1.11 R, 1.202, 1.208, 200, 481, 87.01; D12/108, 112

[56] References Cited

U.S. PATENT DOCUMENTS

D. 58,255 6/1921 Phillips D21/76

D. 252,829	9/1979	Nakao et al.	D21/74
672,620	4/1901	Horton	280/1.11 R
696,315	3/1902	Cooper	280/1.11 R
3,804,427	4/1974	Lohr et al.	280/1.11 R

Primary Examiner—Charles A. Rademaker
Attorney, Agent, or Firm—Edward D. O'Brian

[57] CLAIM

The ornamental design for a toy vehicle, substantially as shown and described.

DESCRIPTION

FIG. 1 is a perspective view of a toy vehicle showing my new design;
FIG. 2 is a rear elevational view thereof;
FIG. 3 is a side elevational view thereof;
FIG. 4 is a bottom plan view thereof;
FIG. 5 is a rear perspective view of a modified form of the design shown in FIGS. 1 through 4, shown partially in fragment; and,
FIG. 6 is a rear perspective view of another modified form of the design shown in FIGS. 1 through 4, shown partially in fragment.

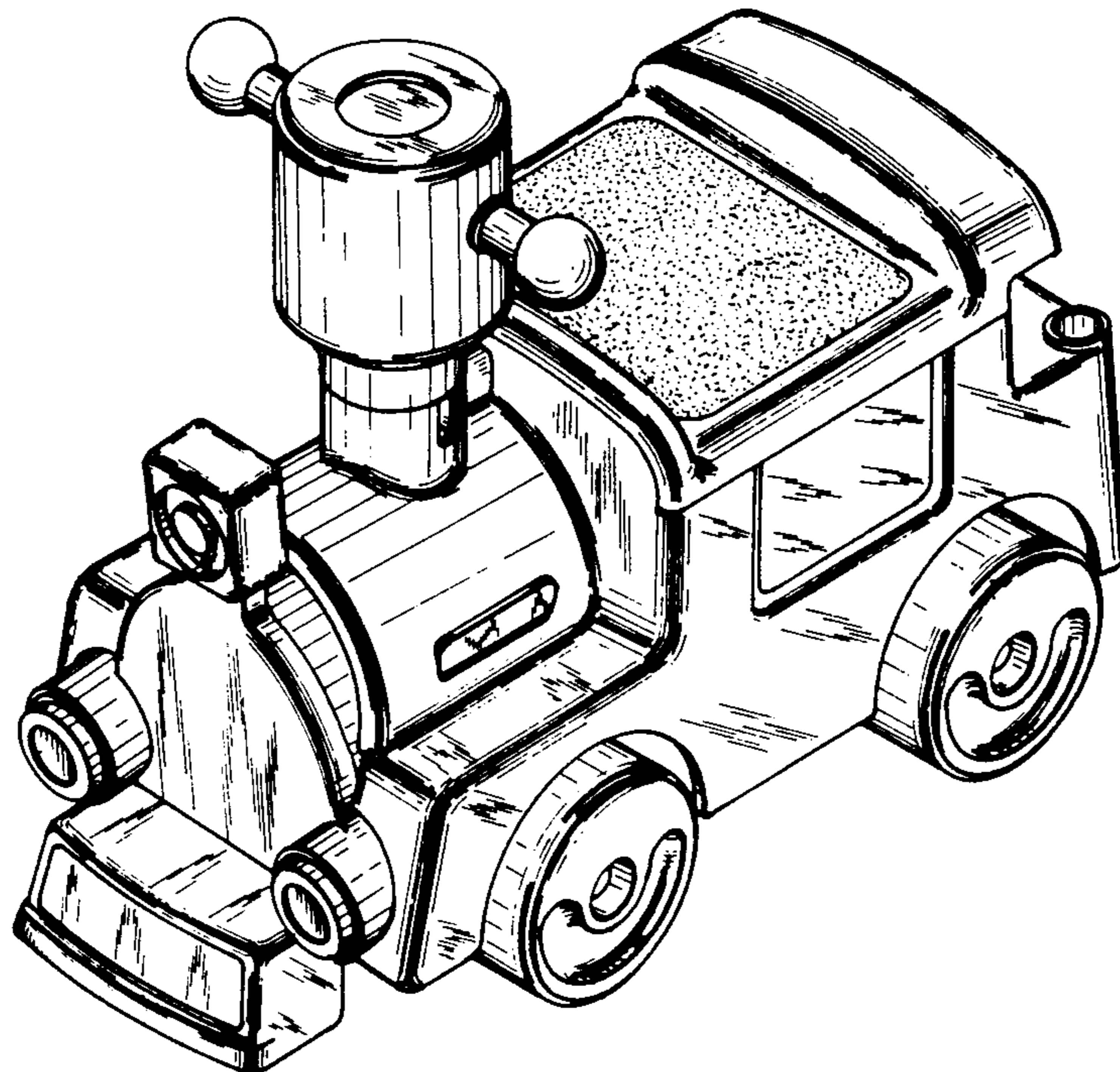

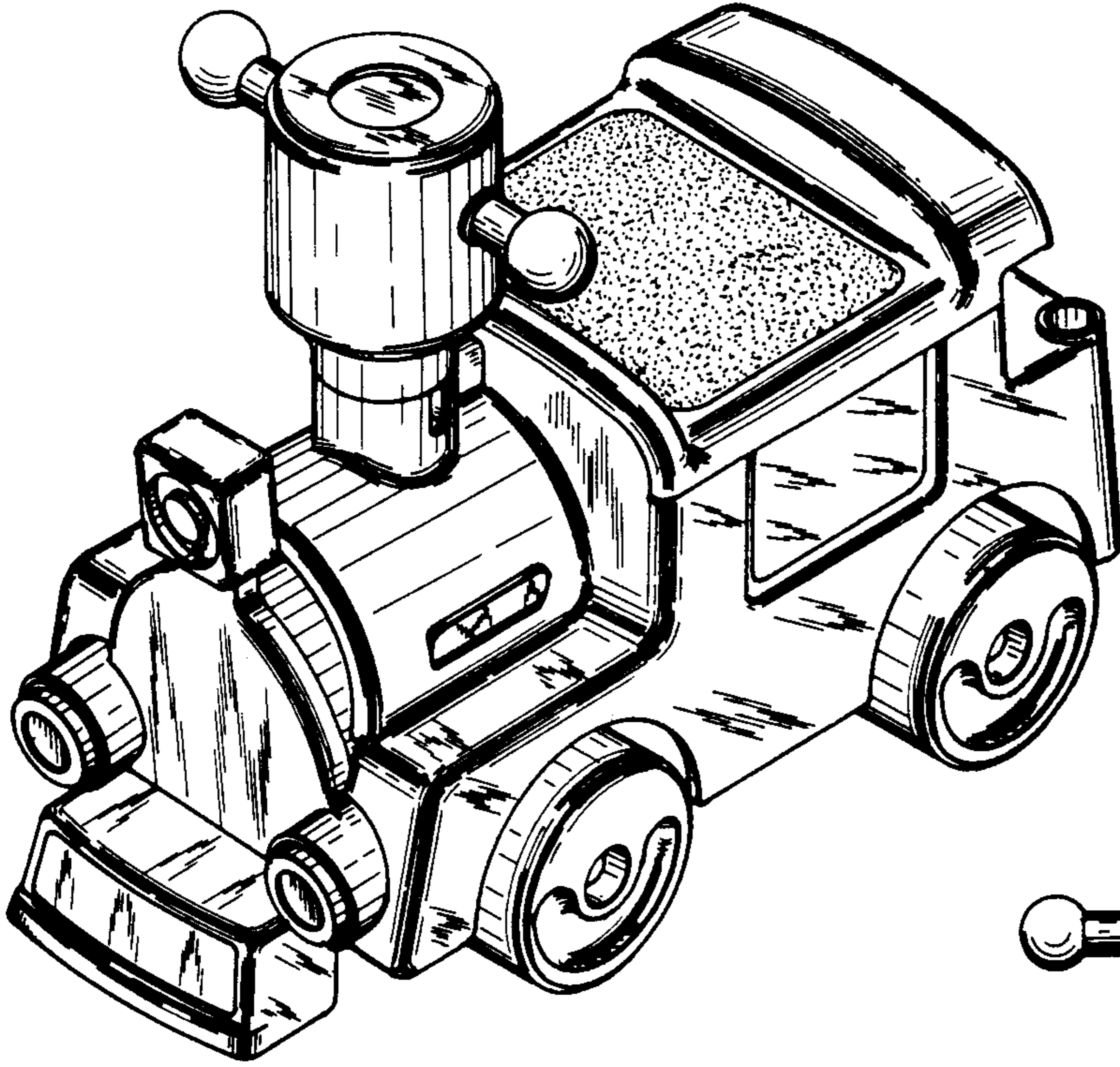

Fig. 1

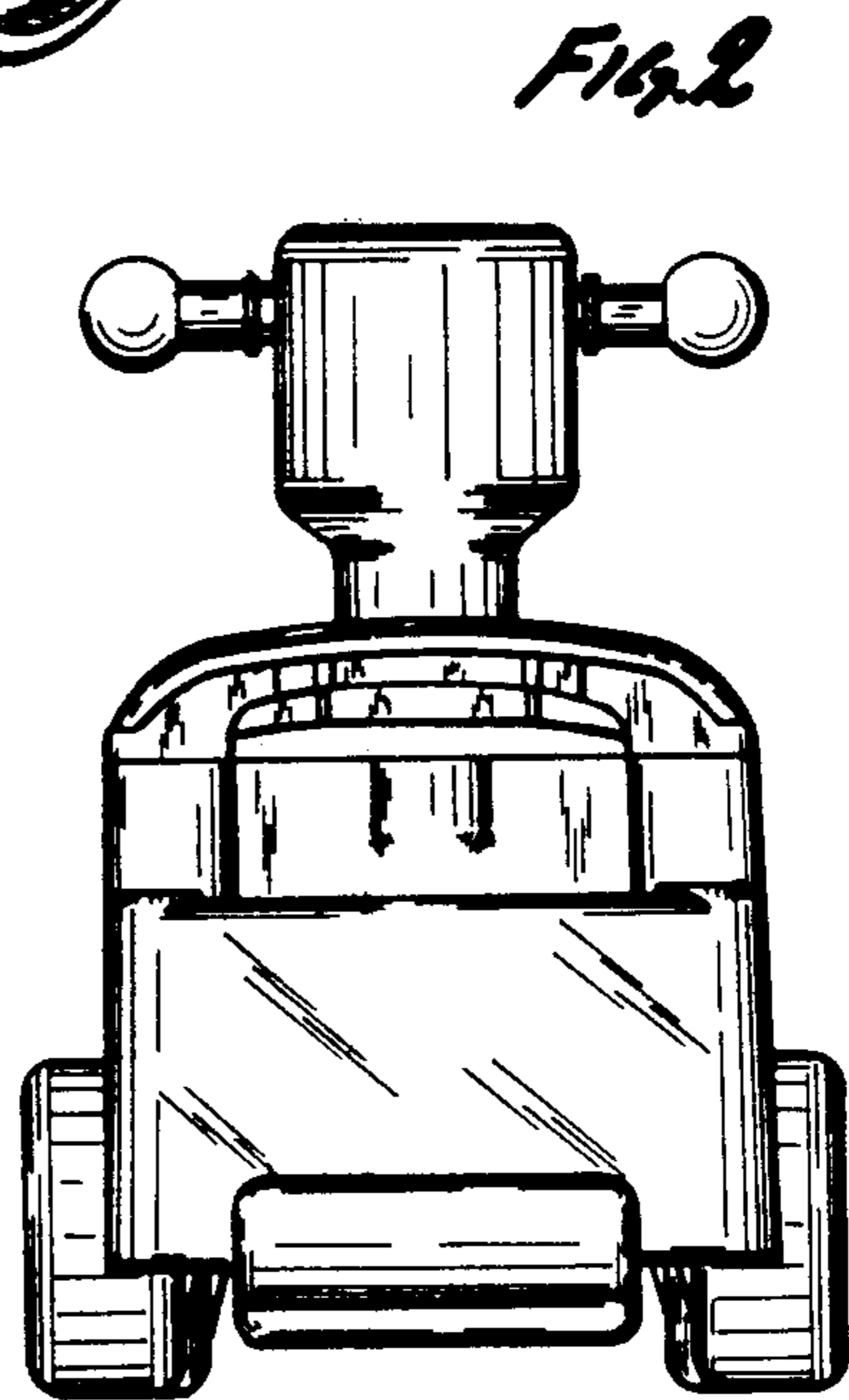

Fig. 2

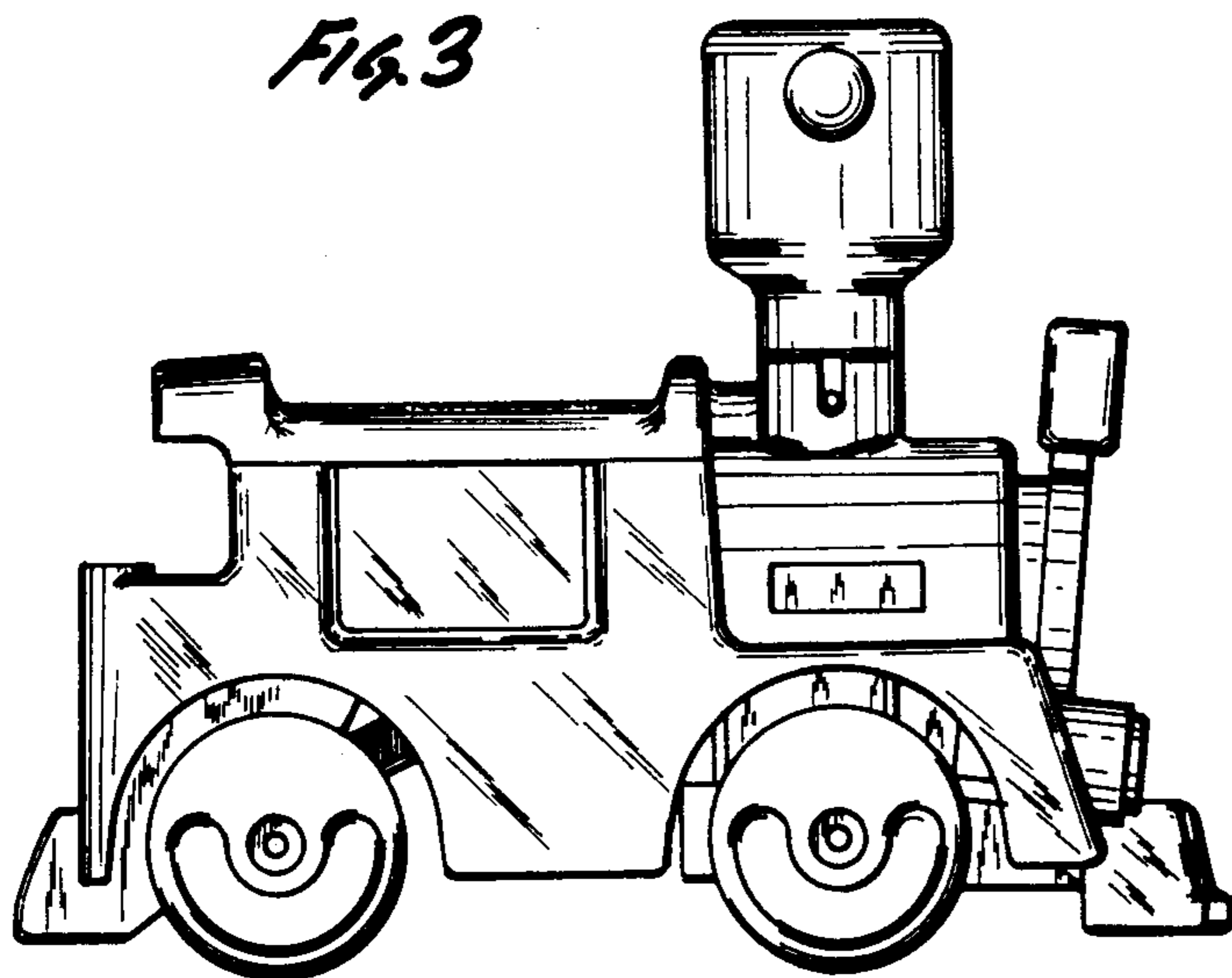

Fig. 3

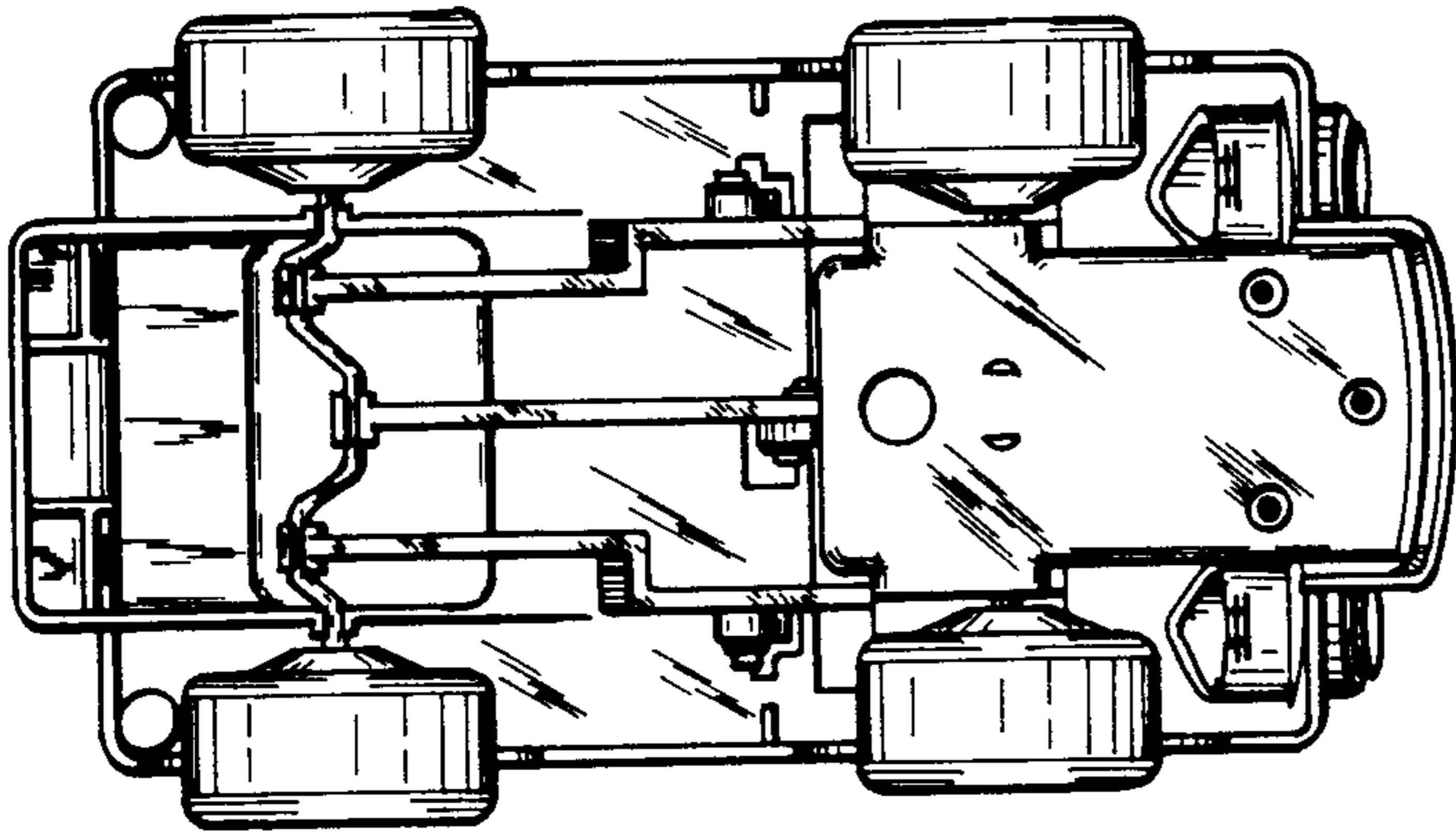

Fig. 4

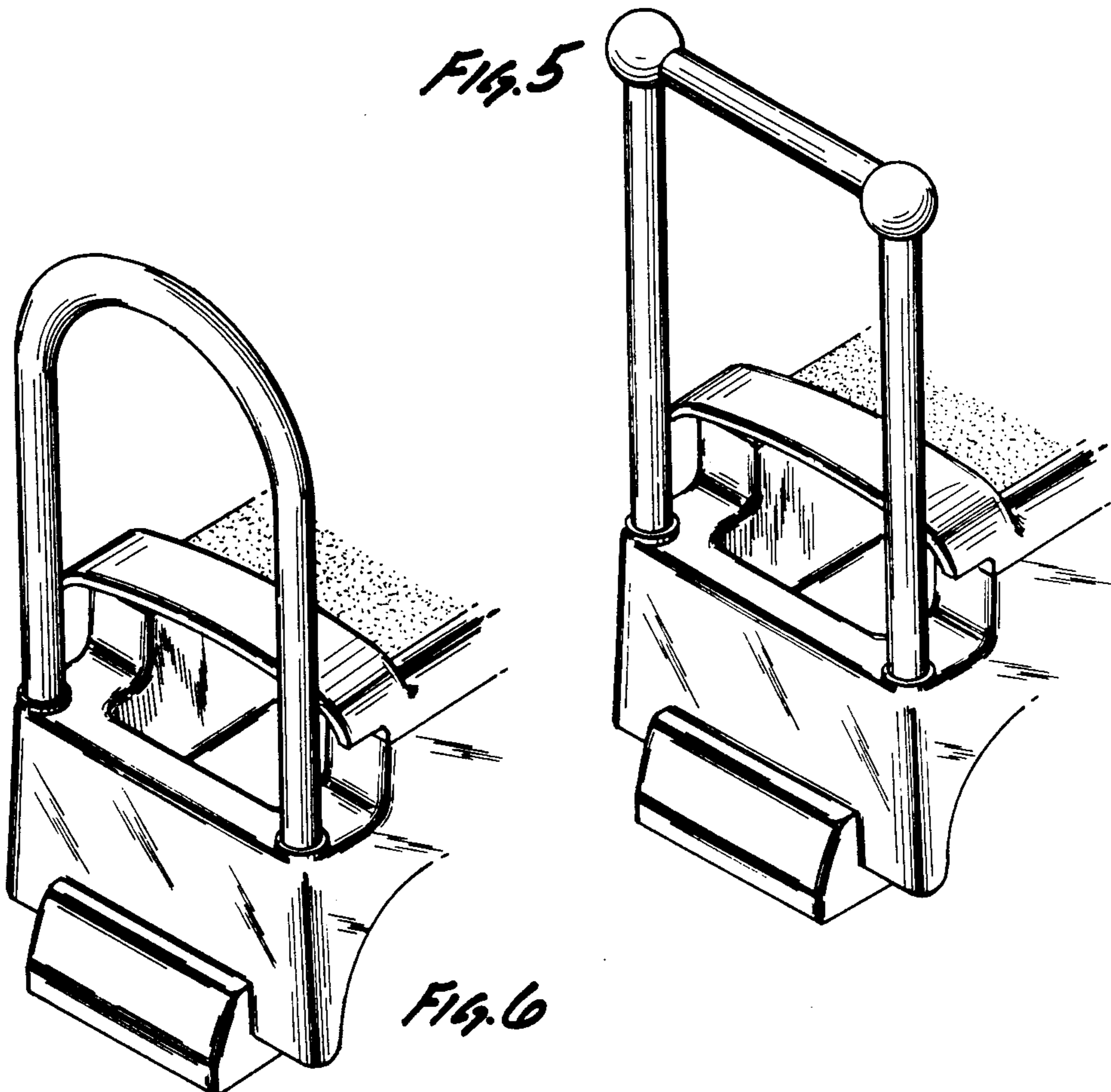

Fig. 5

Fig. 6