

[54] AUTOMOTIVE WHEEL CENTER

[76] Inventor: Richard G. Weld, 933 Mulberry, Kansas City, Mo. 64101

[**] Term: 14 Years

[21] Appl. No.: 6,192

[22] Filed: Jan. 24, 1979

Related U.S. Application Data

[63] Continuation-in-part of Ser. No. 896,912, Apr. 17, 1978, abandoned.

[51] Int. Cl. D12-16

[52] U.S. Cl. D12/205

[58] Field of Search D12/205; 301/95, 95 B, 301/95 C, 37 SS, 63 R, 63 DD, 63 DT, 63 PW, 55, 58, 59, 64 R, 65, 66, 64 SH, 64 SD, 73, 74, 79

[56] References Cited

U.S. PATENT DOCUMENTS

1,959,007 5/1934 Schweitzer 301/58
2,019,120 10/1935 Cunningham et al. D12/205

Primary Examiner—James M. Gandy
Attorney, Agent, or Firm—Claude A. Fishburn

[57] CLAIM

The ornamental design for an automotive wheel center, as shown and described.

DESCRIPTION

FIG. 1 is a perspective view of the design for an automotive wheel center, it being understood that the broken lines are for illustrative purposes only. FIG. 2 is a front elevational view thereof. FIG. 3 is a rear elevational view thereof.

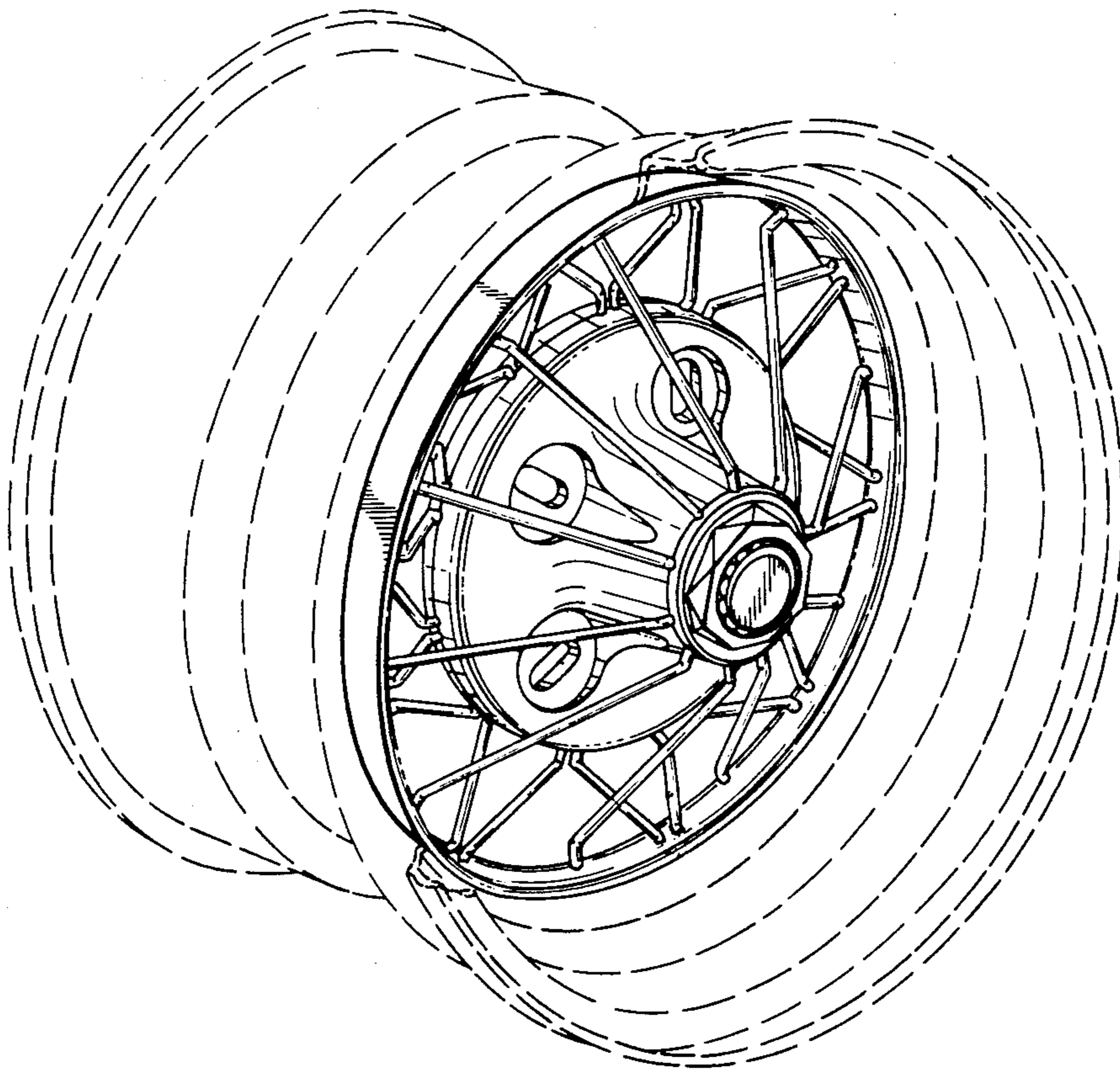

Fig. 1.

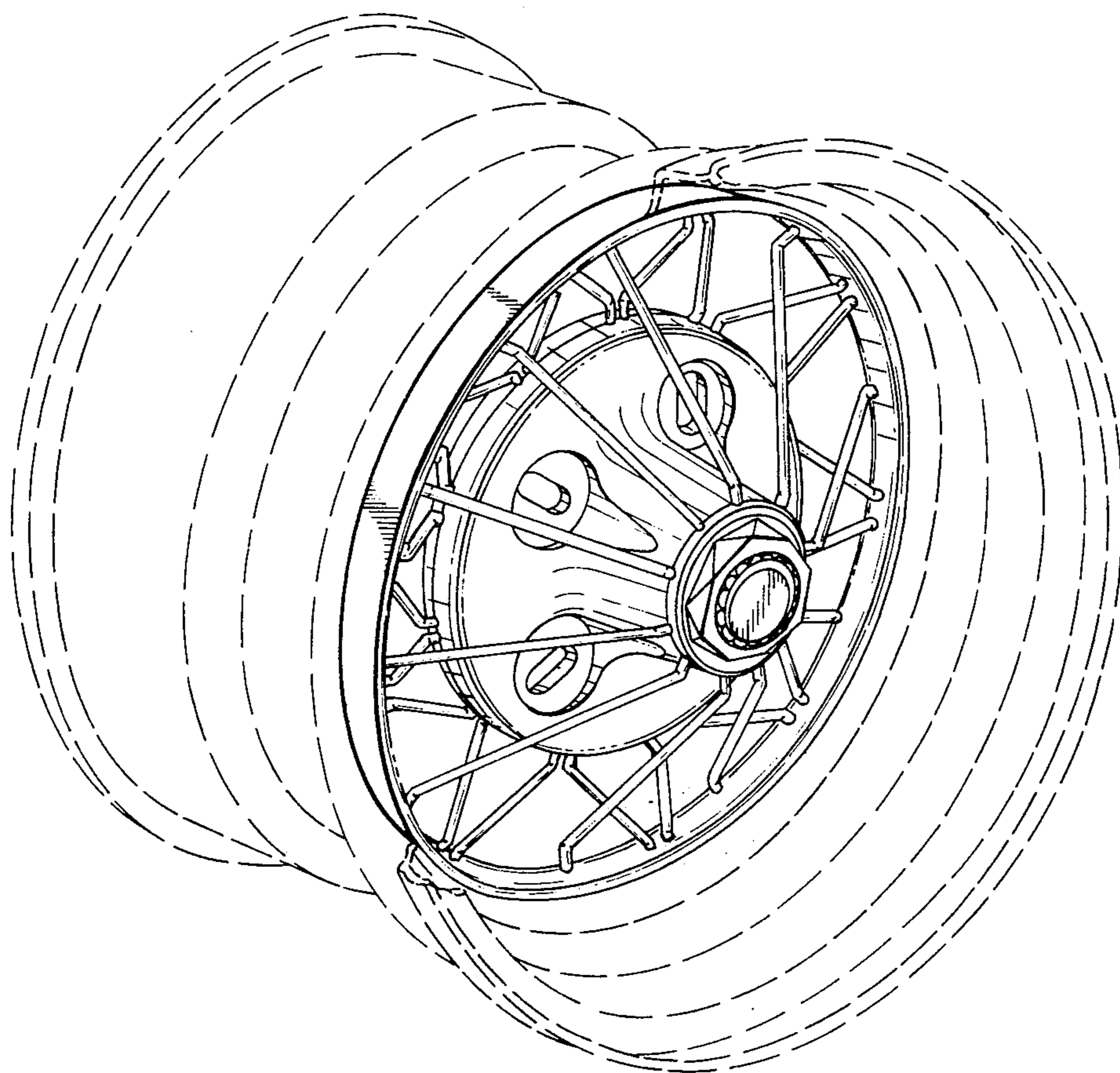

Fig. 2.

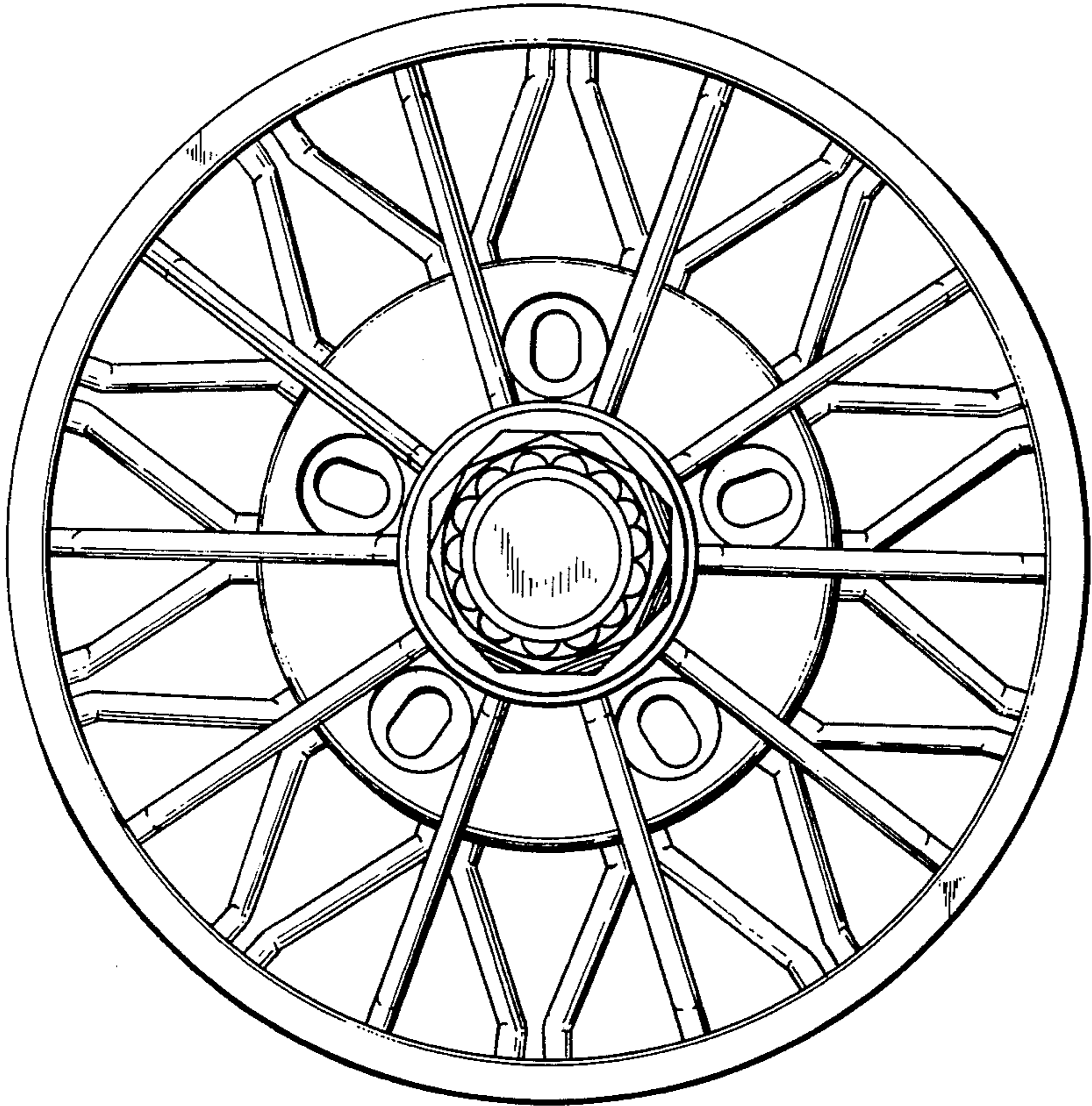

Fig. 3.

