

[54] **AUTOMOBILE WHEEL**

[75] Inventor: **Philip G. Patch**, Mission Viejo, Calif.

[73] Assignee: **Keystone Products, Inc.**, Ontario, Calif.

[**] Term: **14 Years**

[21] Appl. No.: **57,425**

[22] Filed: **Jul. 13, 1979**

[51] Int. Cl. **D12-16**

[52] U.S. Cl. **D12/209**

[58] Field of Search **D12/209, 210; 301/63, 301/64 R, 64 SD, 65, 66**

[56] **References Cited**

U.S. PATENT DOCUMENTS

- | | | | | |
|------------|---------|----------|-------|---------|
| D. 225,989 | 1/1973 | Chadwick | | D12/209 |
| D. 246,239 | 11/1977 | Kozloski | | D12/209 |

OTHER PUBLICATIONS

Competition Press & Autoweek, 5/29/71, p. 39, Sportstar wheel, upper left side of page.

Primary Examiner—James M. Gandy

[57] **CLAIM**

The ornamental design for an automobile wheel, as shown.

DESCRIPTION

FIG. 1 is a front elevational view of an automobile wheel showing my new design;
FIG. 2 is a rear elevational view thereof;
FIG. 3 is a side elevational view thereof;
FIG. 4 is a perspective view thereof on a reduced scale;
FIG. 5 is a cross-sectional view thereof, taken along lines 5—5 of FIG. 1; and
FIG. 6 is a cross-sectional view thereof, taken along lines 6—6 of FIG. 1.

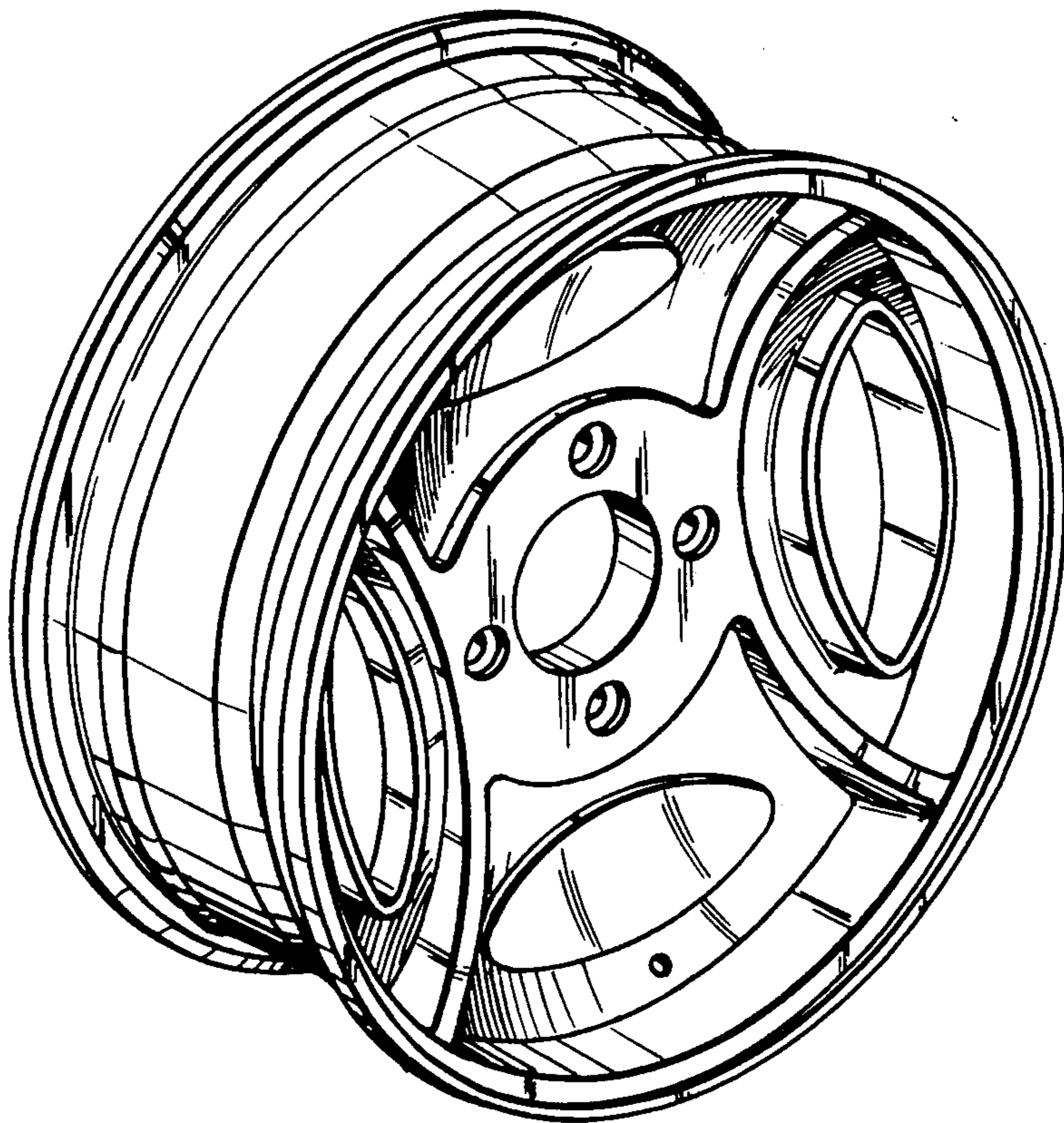

Fig. 1

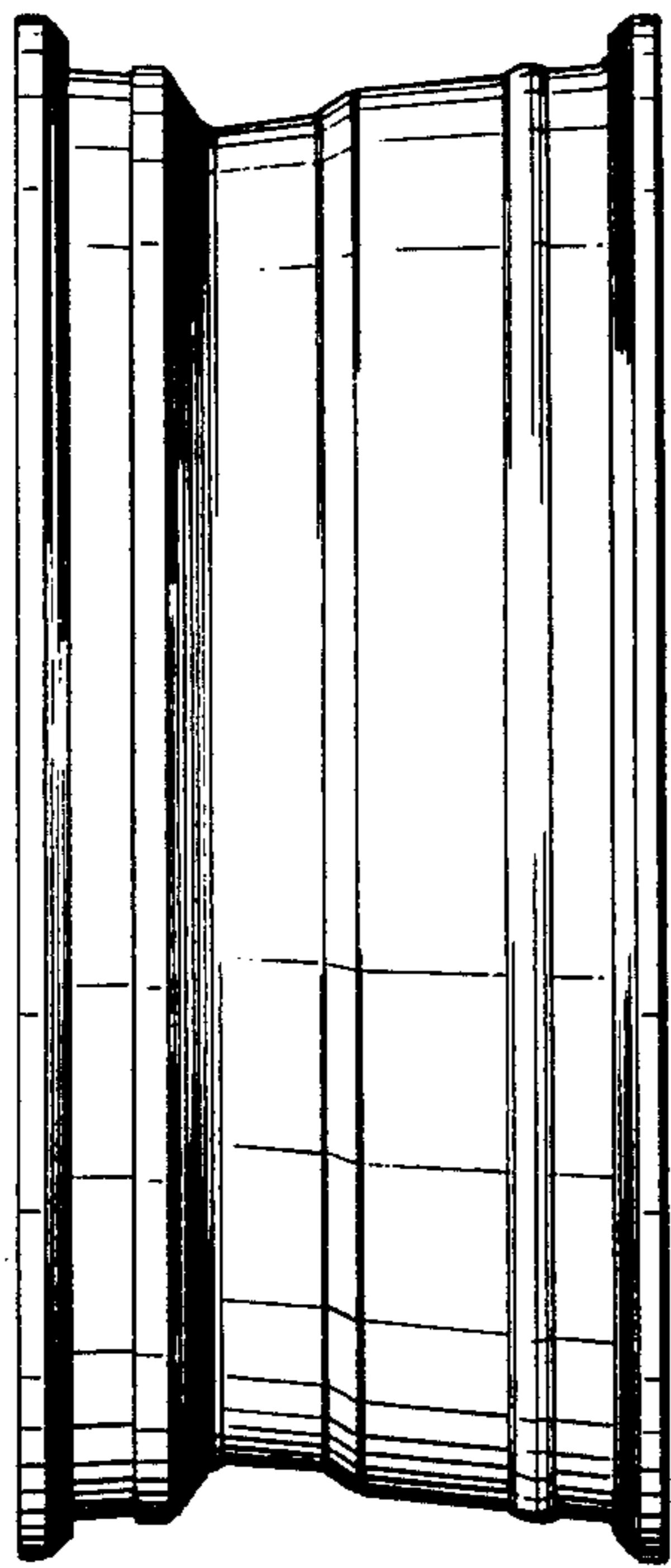
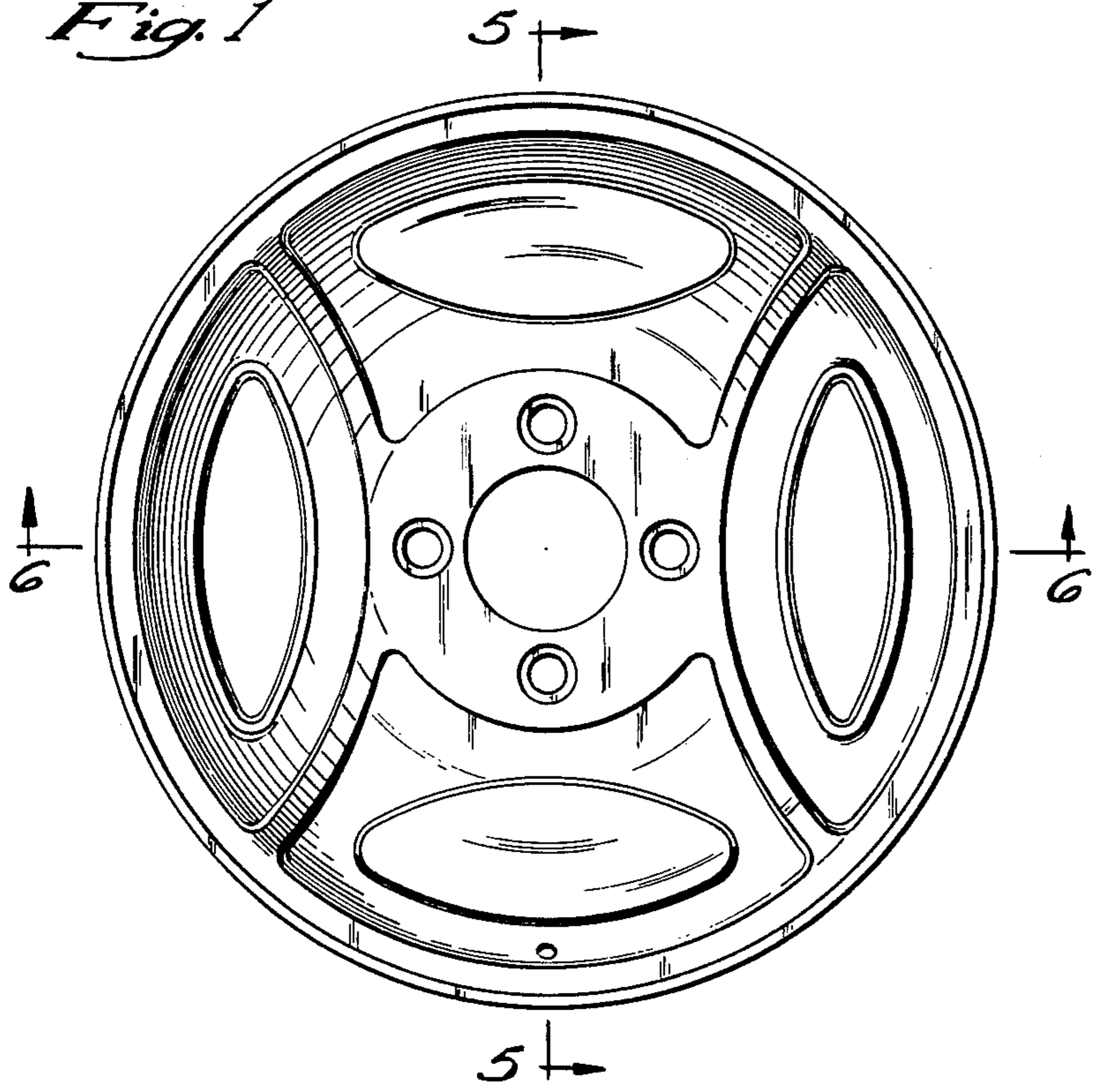

Fig. 3

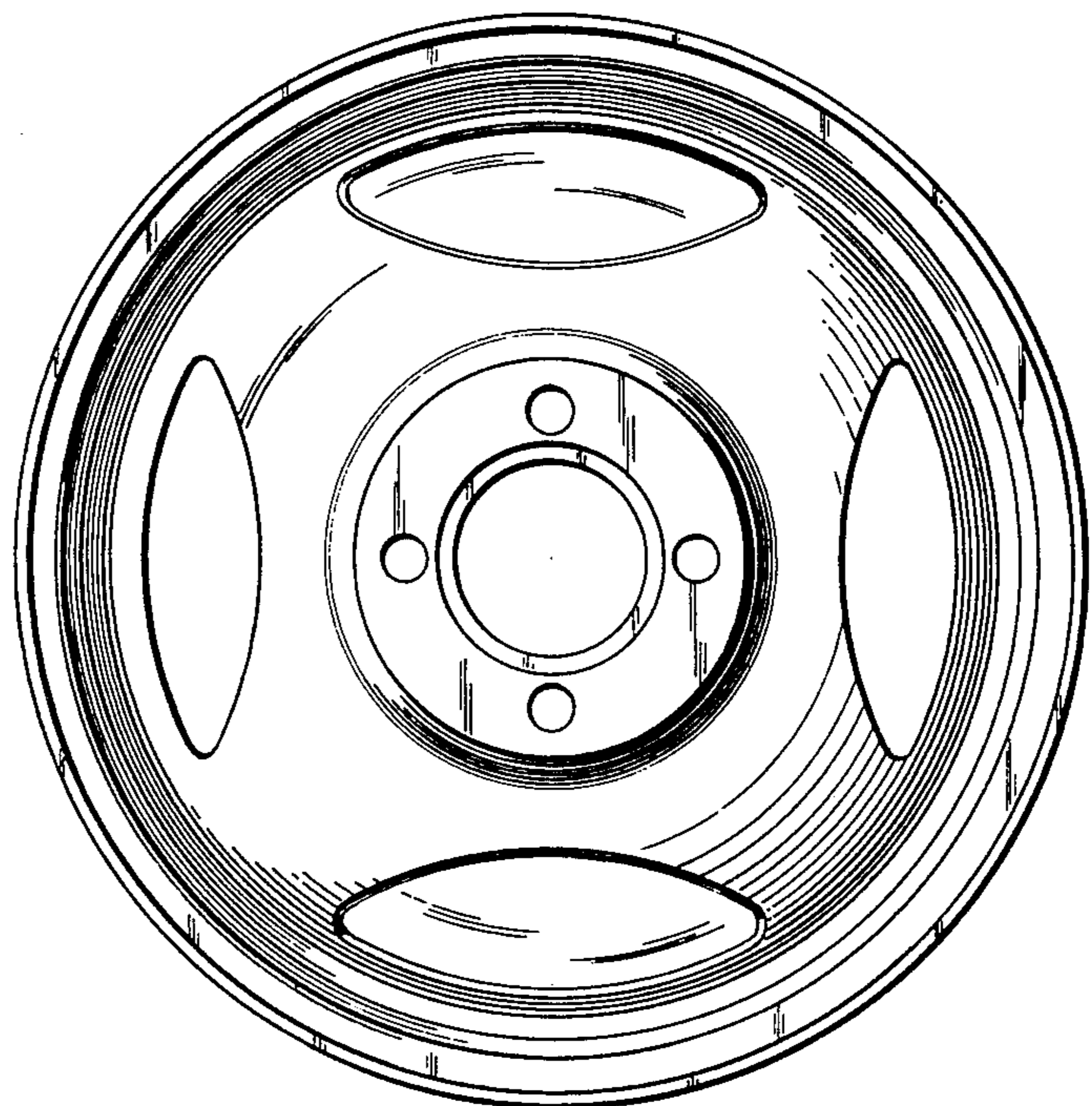

Fig. 2

Fig. 4

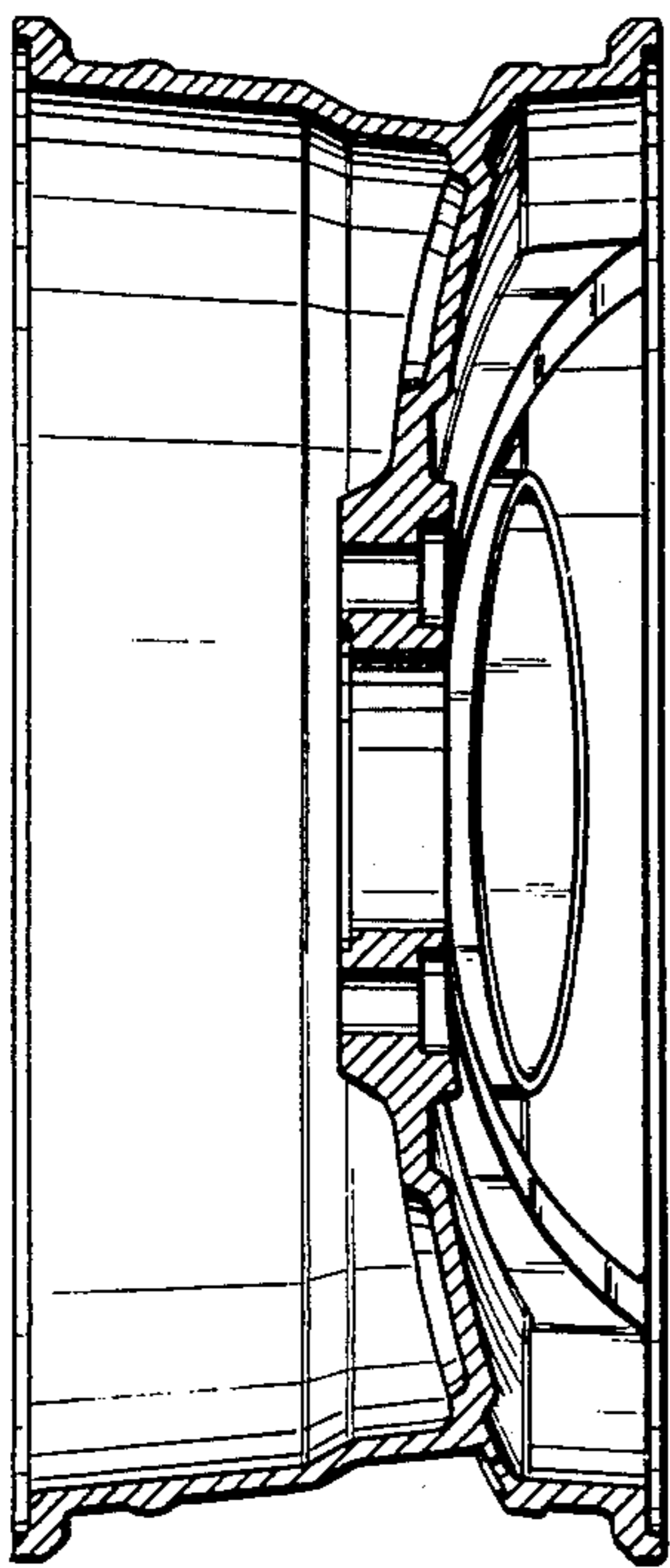
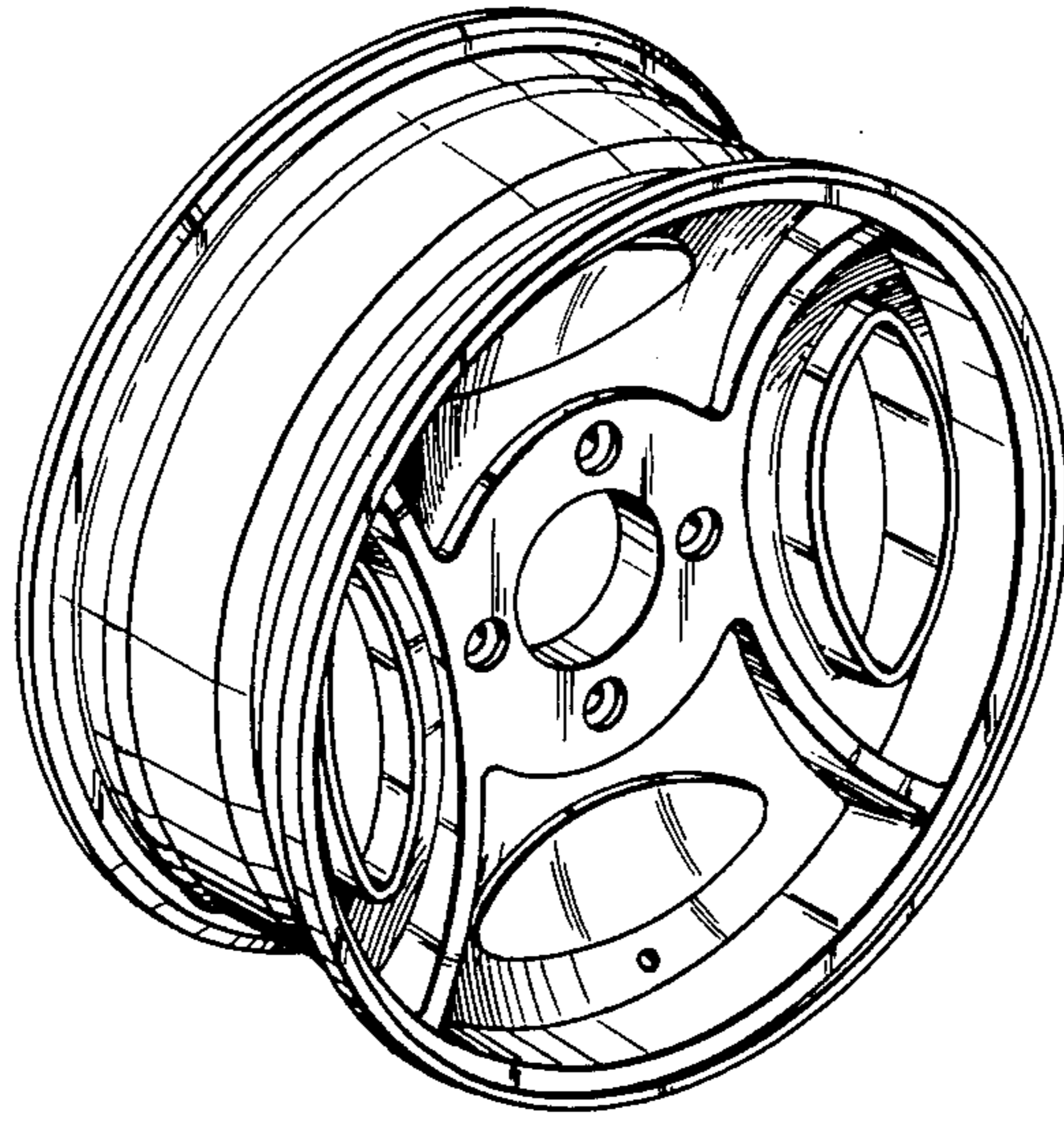

Fig. 5

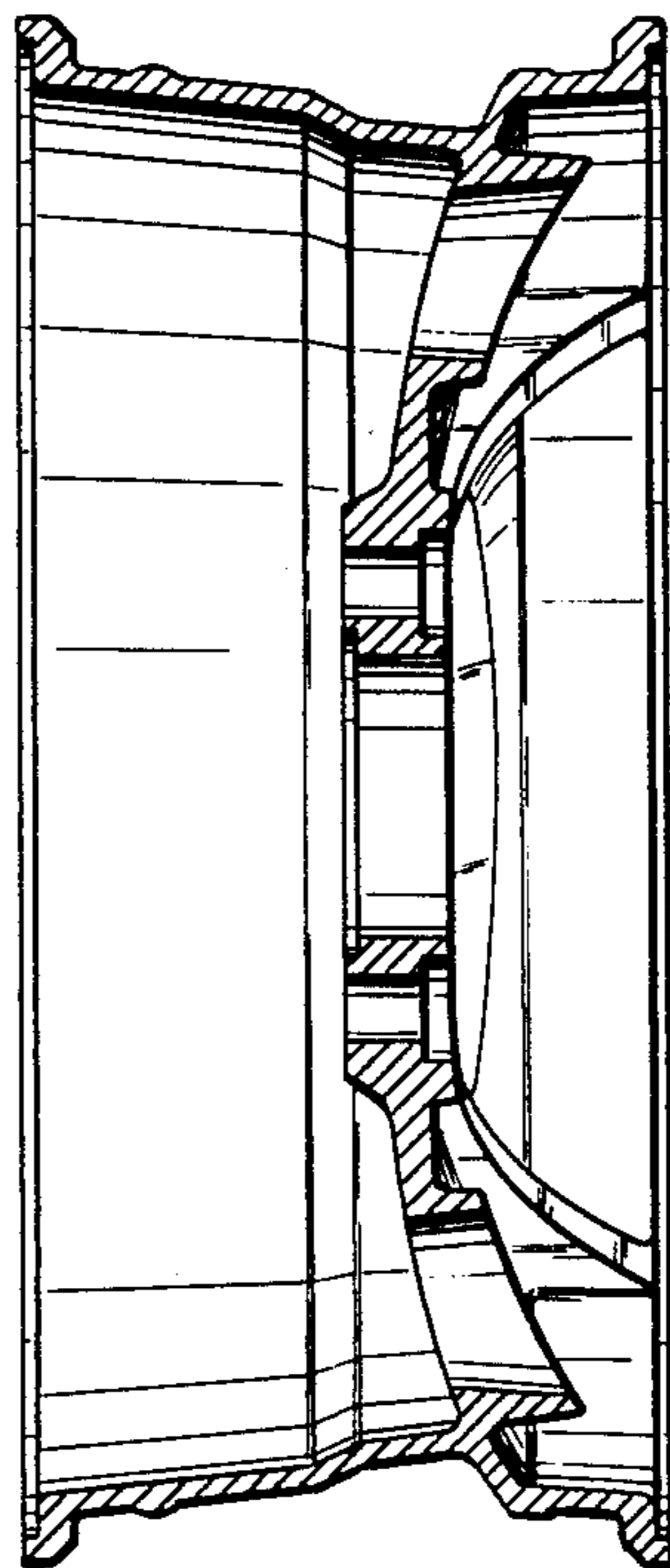

Fig. 6