

[54] COMBINED TABLE AND MULTIPLE SEAT UNIT

3,120,405 2/1964 Soszynski ..... 297/174 X  
3,542,420 11/1970 Priewe ..... 297/157

[75] Inventor: Gordon W. Shumaker, St. Paul, Minn.

Primary Examiner—Bruce W. Dunkins  
Attorney, Agent, or Firm—Clayton R. Johnson

[73] Assignee: Space Tables, Inc.

[\*\*] Term: 14 Years

[57] CLAIM

[21] Appl. No.: 955,028

The ornamental design for a combined table and multiple seat unit, substantially as shown and described.

[22] Filed: Oct. 26, 1978

DESCRIPTION

[51] Int. Cl. .... D6-05

FIG. 1 is a top plan view of a combined table and multiple seat unit showing my design;

[52] U.S. Cl. .... D6/45

FIG. 2 is a side elevational view; and

[58] Field of Search ..... D6/27, 42-45,  
D6/177, 178, 179, 146; 297/157, 174

FIG. 3 is an end elevational view thereof;

[56] References Cited

U.S. PATENT DOCUMENTS

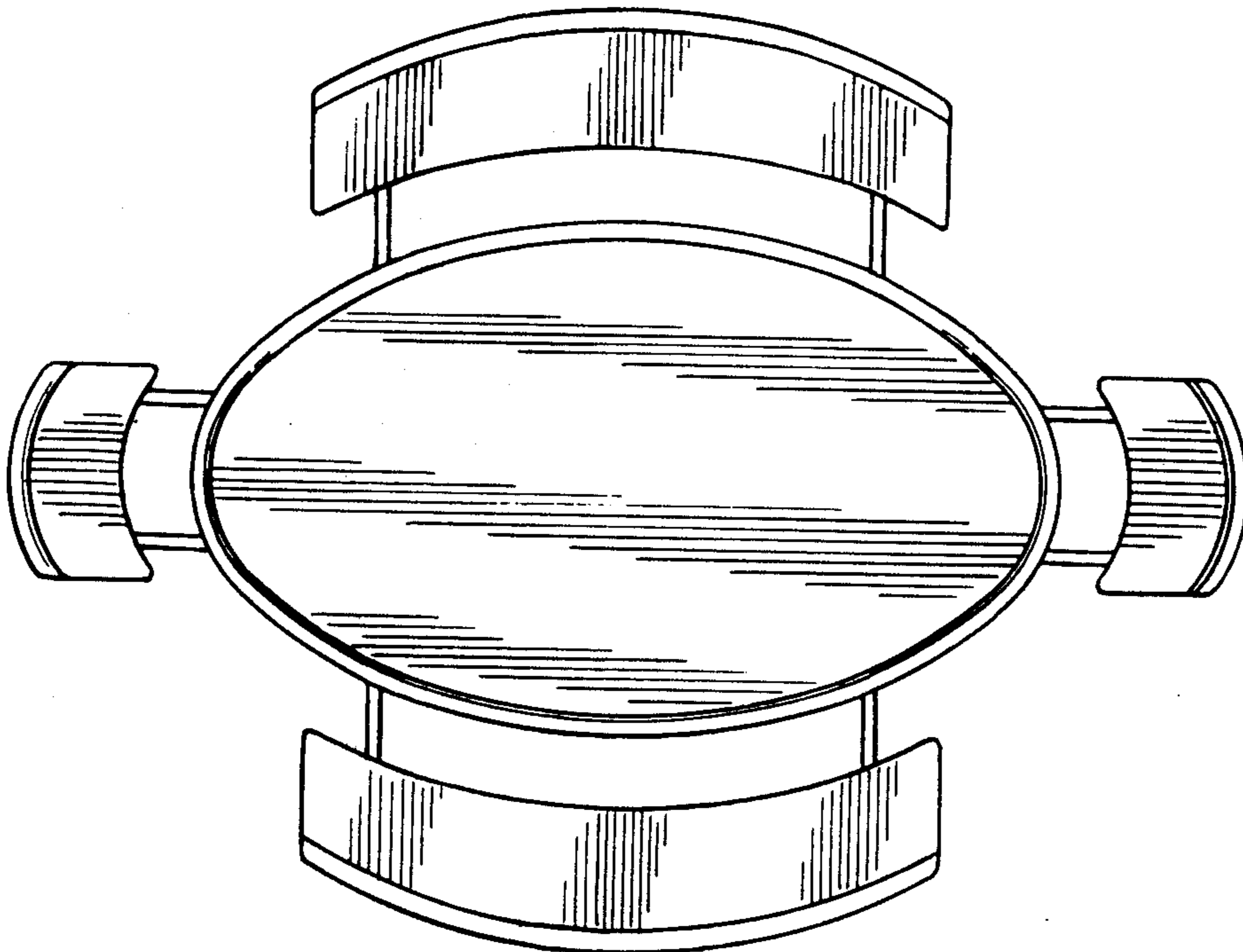
- D. 242,306 11/1976 Campbell et al. .... D6/45
- D. 244,409 5/1977 Arnold ..... D6/45
- 2,367,011 1/1945 Demmien ..... 297/157

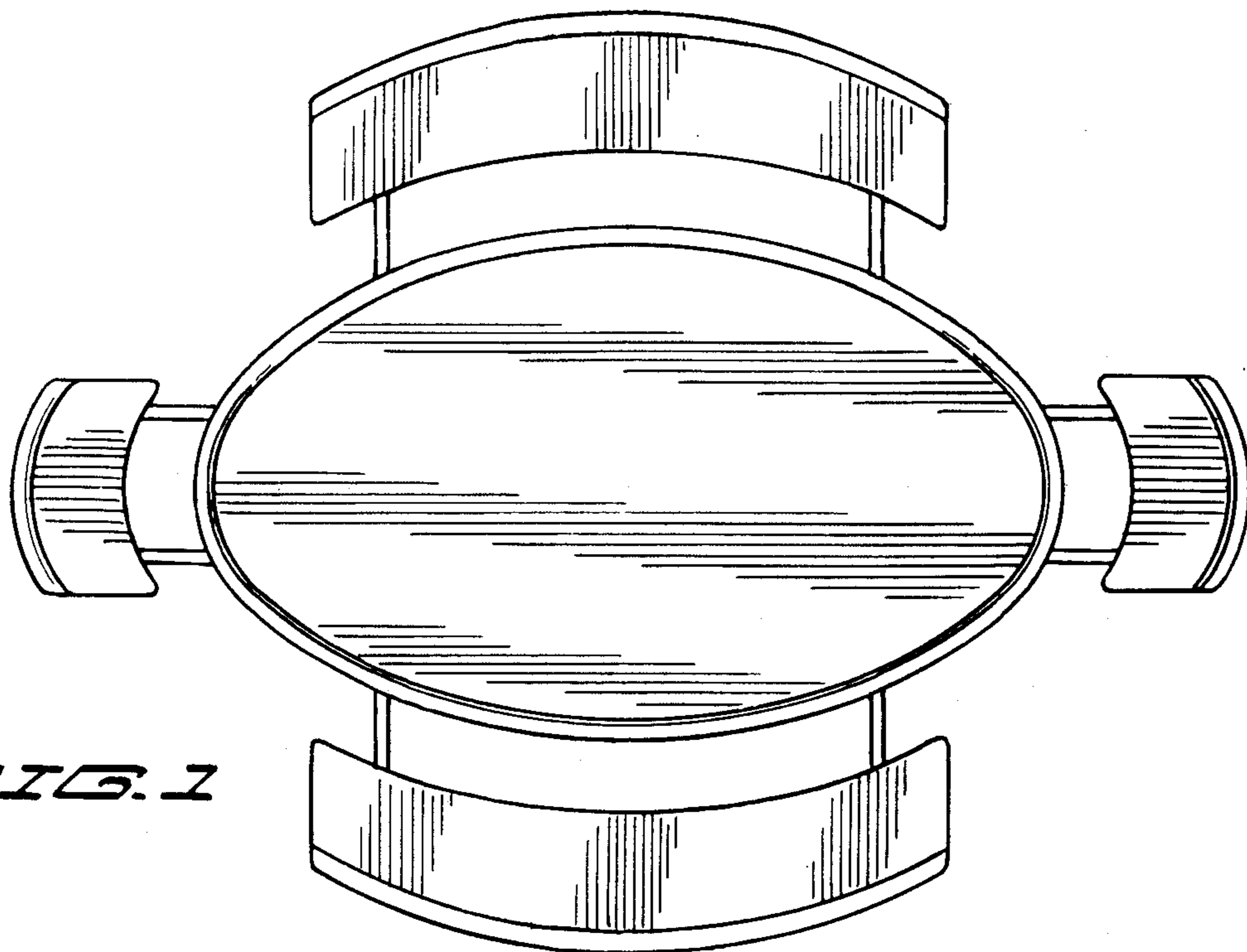
FIG. 4 is a top plan view of a modified form of the combined table and multiple seat unit shown in FIG. 1;

FIG. 5 is a side elevational view; and

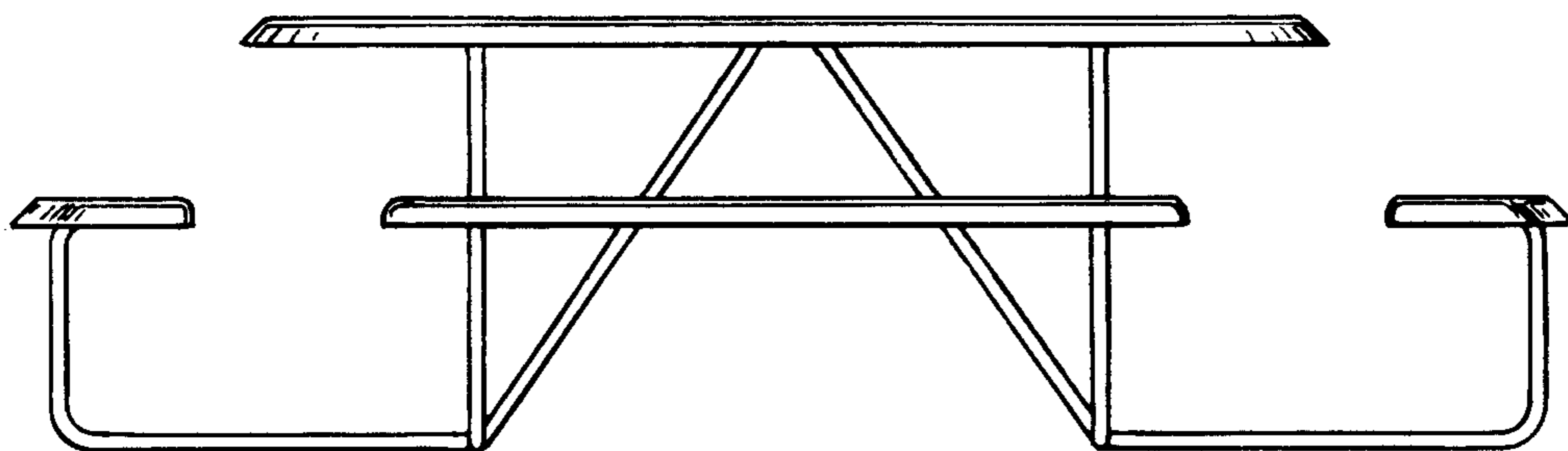
FIG. 6 is an end elevational view thereof.

The sides and ends not shown are mirror images of the sides and ends shown in FIGS. 2, 3, 5 and 6 respectfully.

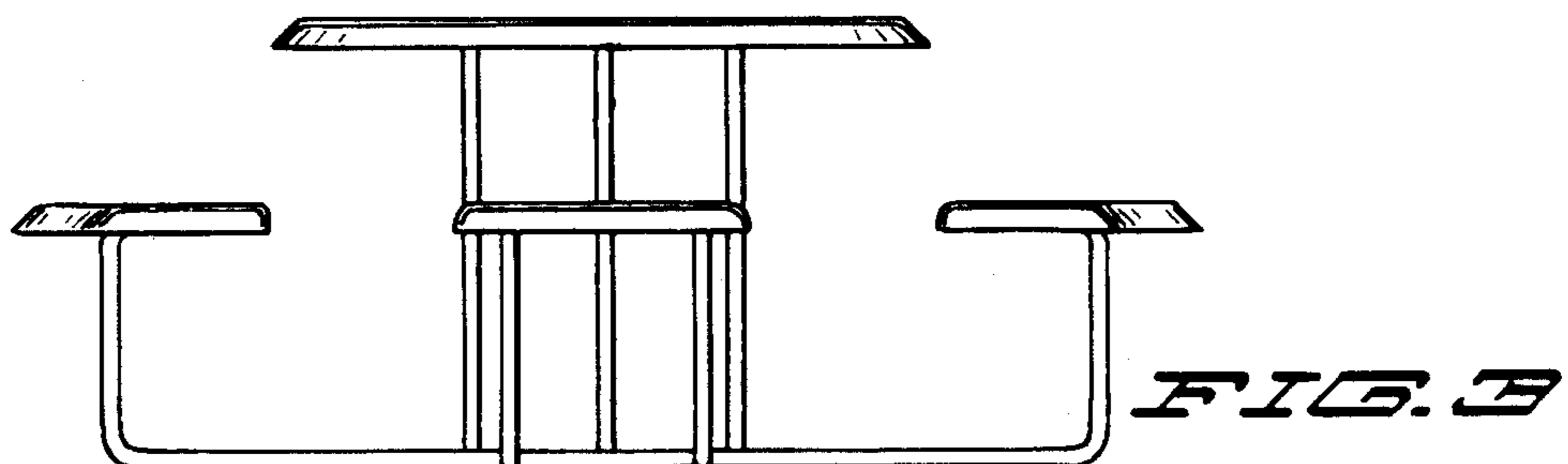




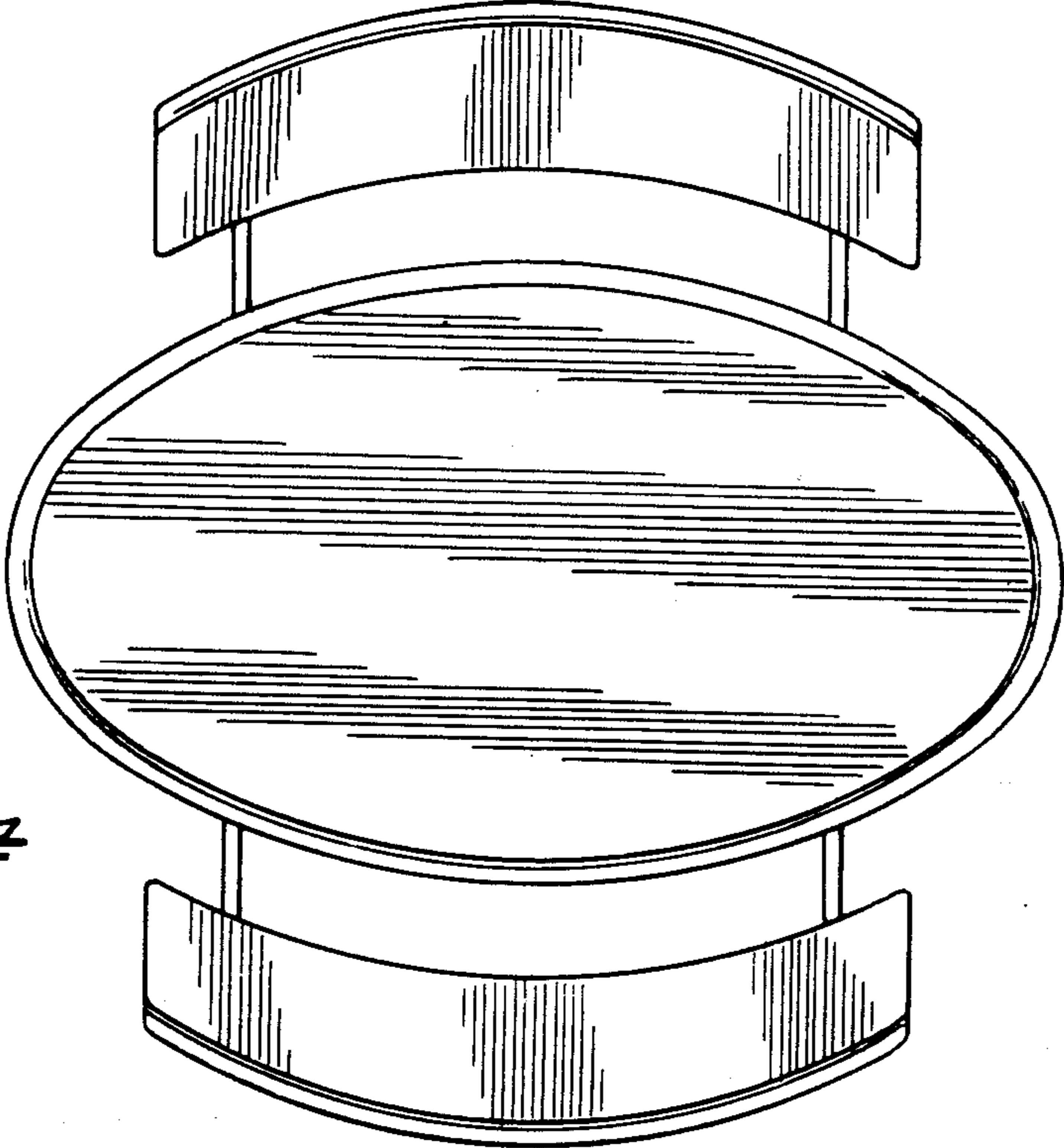
*FIG. 1*



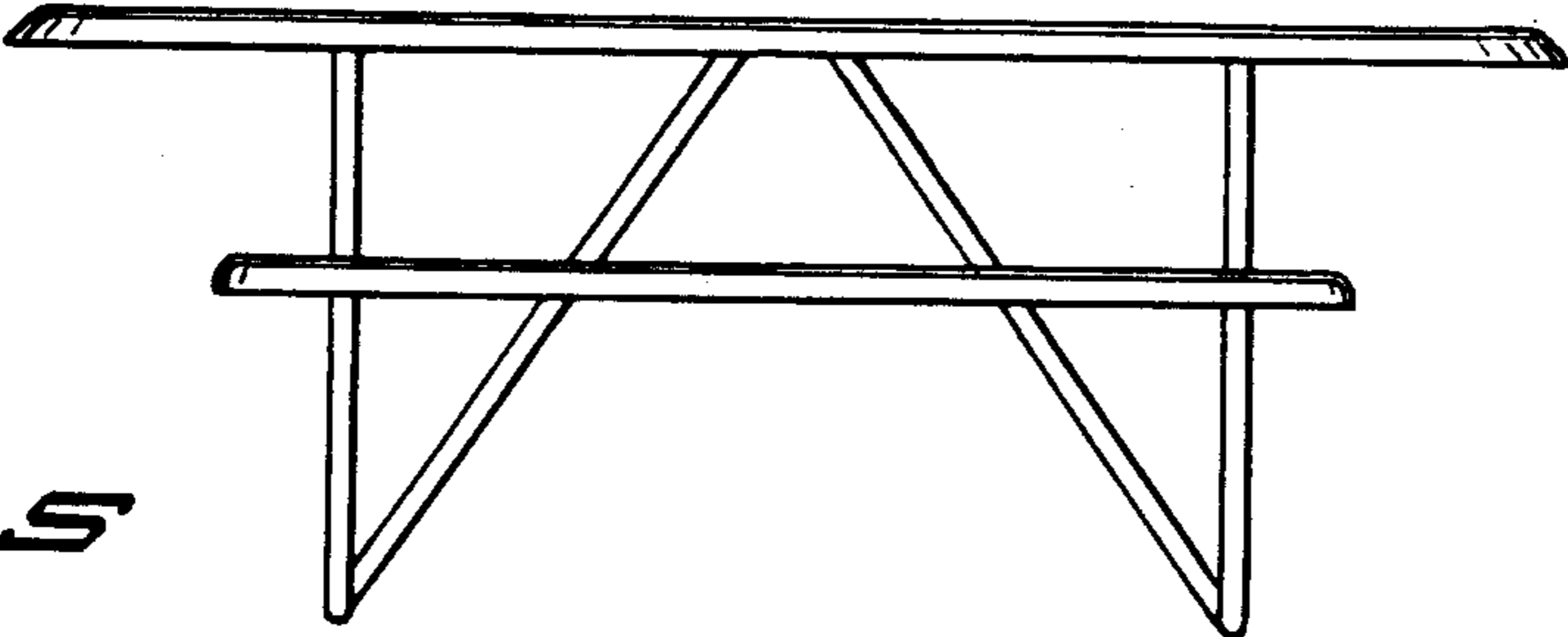
*FIG. 2*



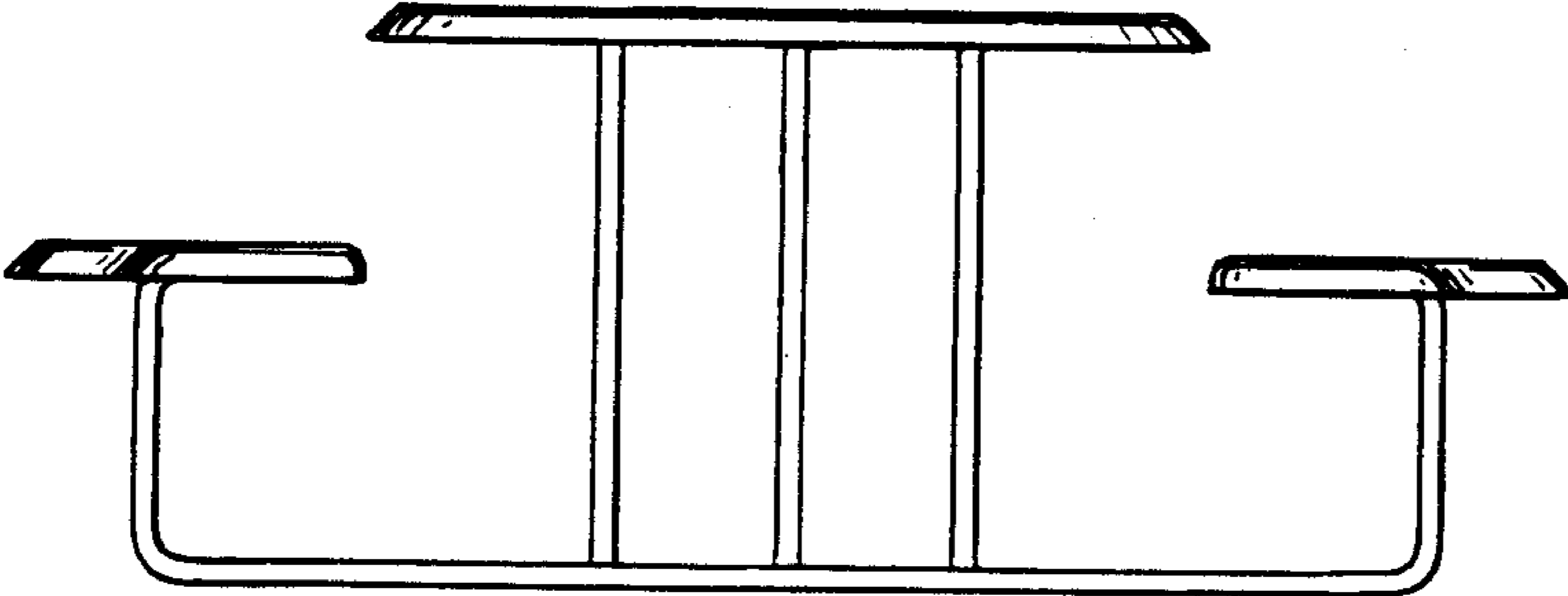
*FIG. 3*



*FIG. 4*



*FIG. 5*



*FIG. 6*