

[54] WASHER SPIN TUBE PULLER

[76] Inventor: Grant F. Hintze, P.O. Box 4951, El Monte, Calif. 91733

[**] Term: 3 1/2 Years

[21] Appl. No.: 875,766

[22] Filed: Feb. 7, 1978

[51] Int. Cl. D08-05

[52] U.S. Cl. D8/51; 29/256; 29/259

[58] Field of Search D8/51; 29/256, 259

[56] References Cited

U.S. PATENT DOCUMENTS

3,902,236 9/1975 Deem 29/256

Primary Examiner—W. Stallard
Attorney, Agent, or Firm—John H. Crowe

[57] CLAIM

The ornamental design for a washer spin tube puller, substantially as shown and described.

DESCRIPTION

FIG. 1 is a perspective view of an embodiment of a washer spin tube puller showing my new design with an L-shaped head plate.

FIG. 2 is a top plan view thereof.

FIG. 3 is a bottom view thereof.

FIG. 4 is a top plan view of an alternative embodiment of a washer spin tube puller showing my new design with a triangular shaped head plate, the washer spin tube puller being otherwise similar to the FIG. 1 embodiment.

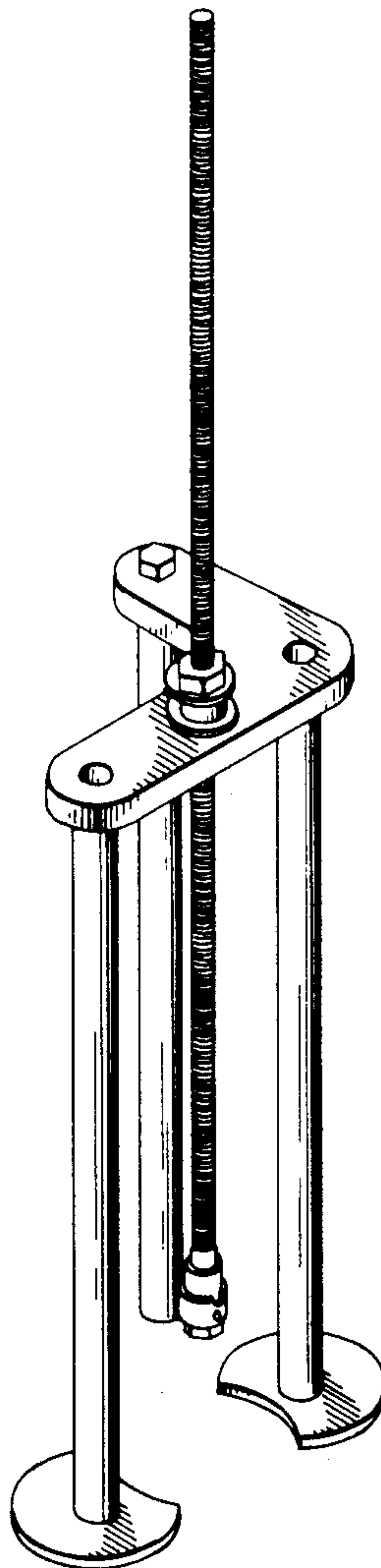

FIG.1.

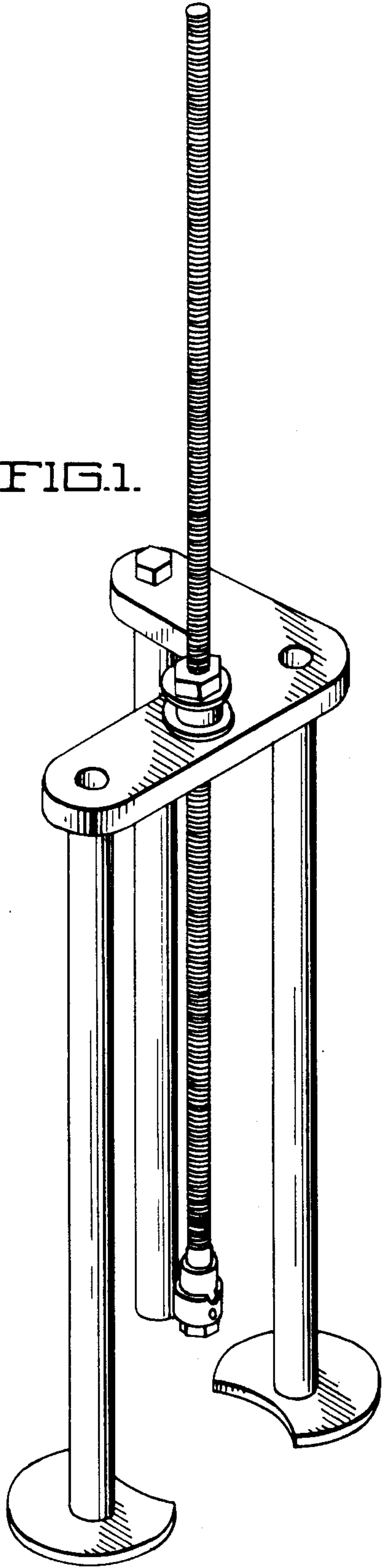

FIG.2.

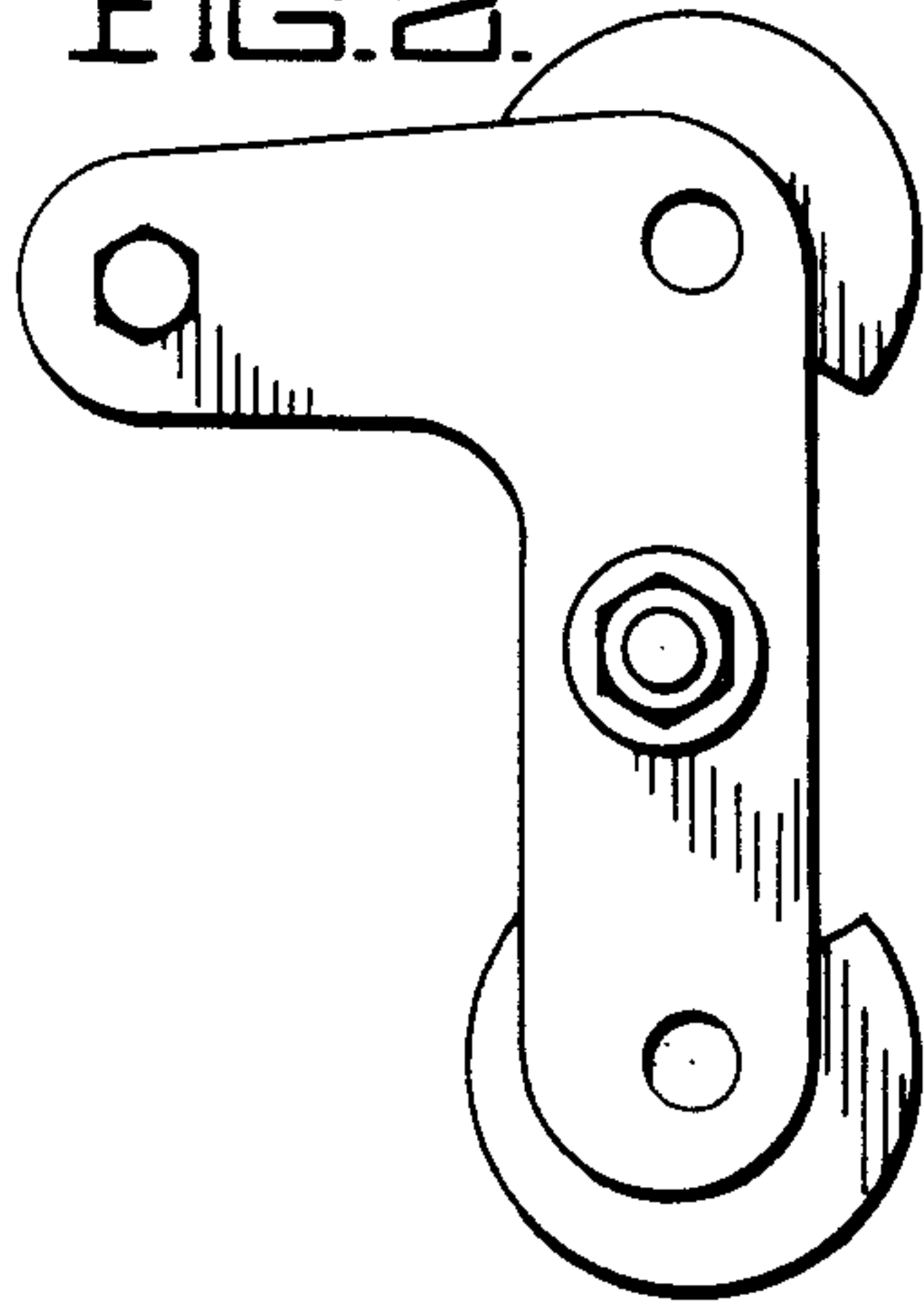

FIG.3.

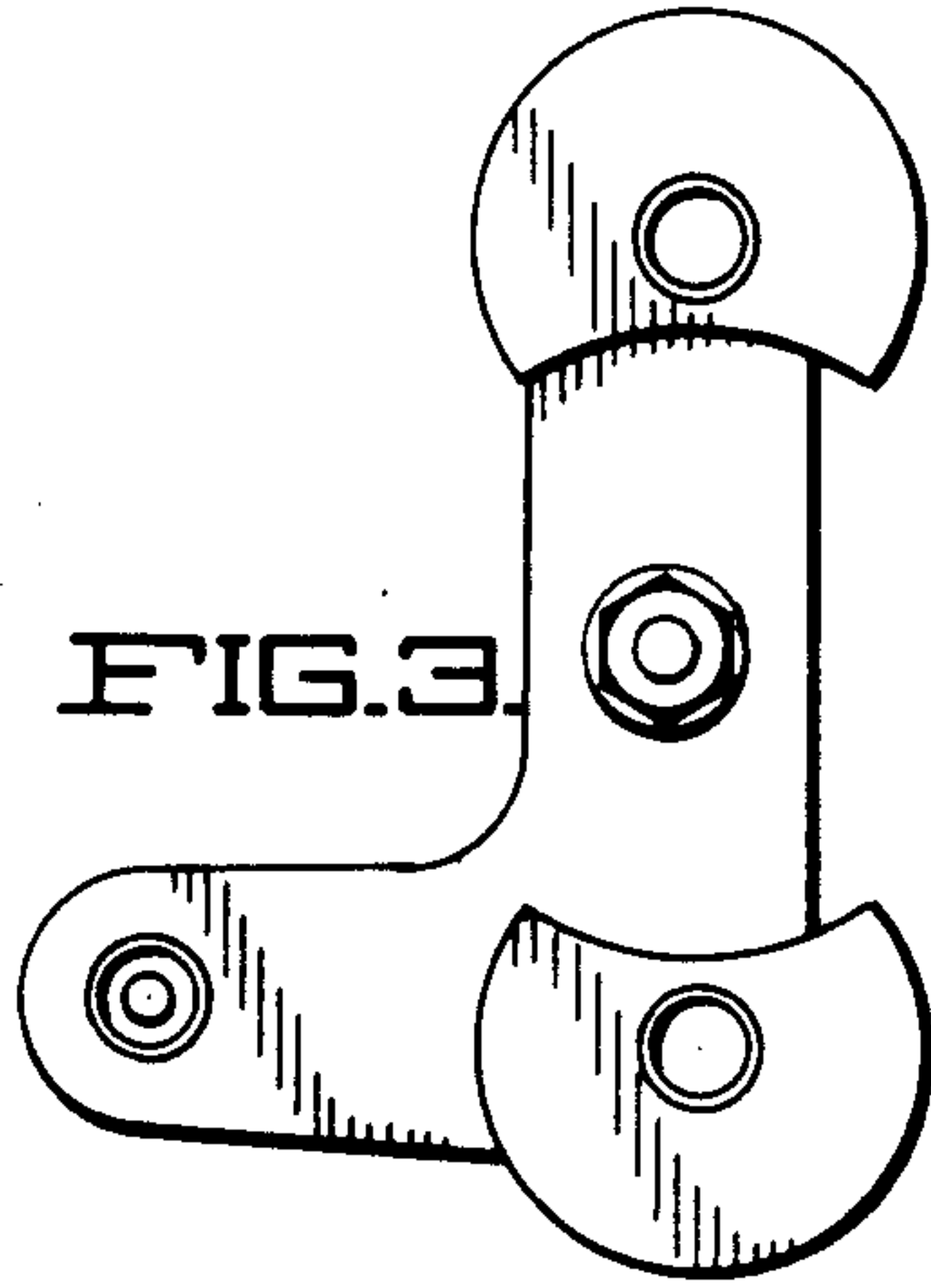

FIG.4.

