

[54] **AMPHIBIOUS PEOPLE POWERED VEHICLE**

[76] **Inventor:** Alton Hudnall, 1720 Lexington Pl., Bedford, Tex. 76021

[\*\*] **Term:** 14 Years

[21] **Appl. No.:** 959,491

[22] **Filed:** Nov. 13, 1978

[51] **Int. Cl.** ..... D12-14  
[52] **U.S. Cl.** ..... D12/3; D12/10  
[58] **Field of Search** ..... D12/3, 10; 115/2

[56] **References Cited**

**U.S. PATENT DOCUMENTS**

D. 225,106 11/1972 Maijala ..... D12/10  
3,954,079 5/1976 Gof ..... 115/2

*Primary Examiner*—Alan P. Douglas  
*Attorney, Agent, or Firm*—Robert A. Felsman

[57] **CLAIM**

The ornamental design for an amphibious people powered vehicle, as shown.

**DESCRIPTION**

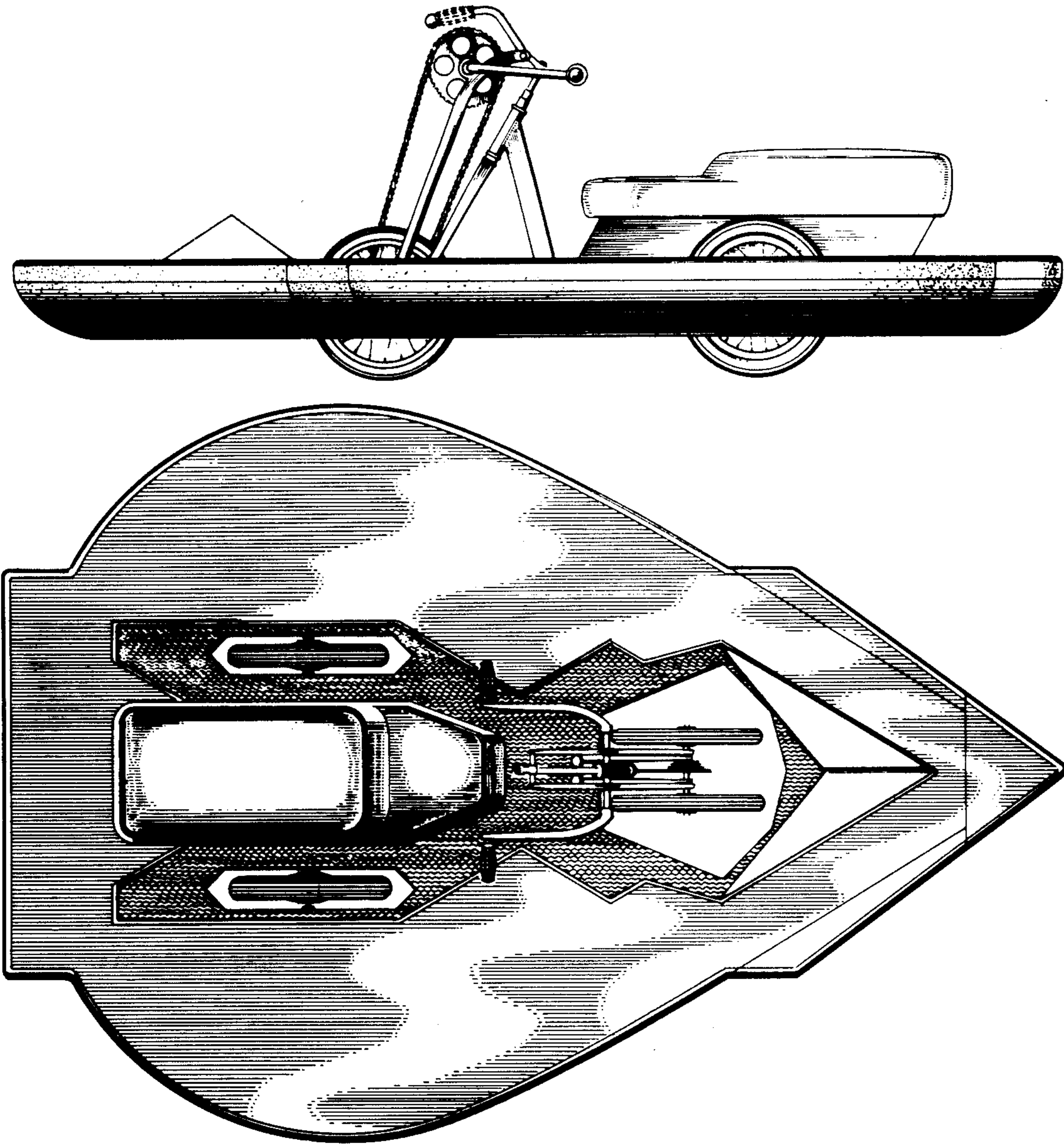
FIG. 1 is a side elevational view of an amphibious people powered vehicle that embodies my new and ornamental design.

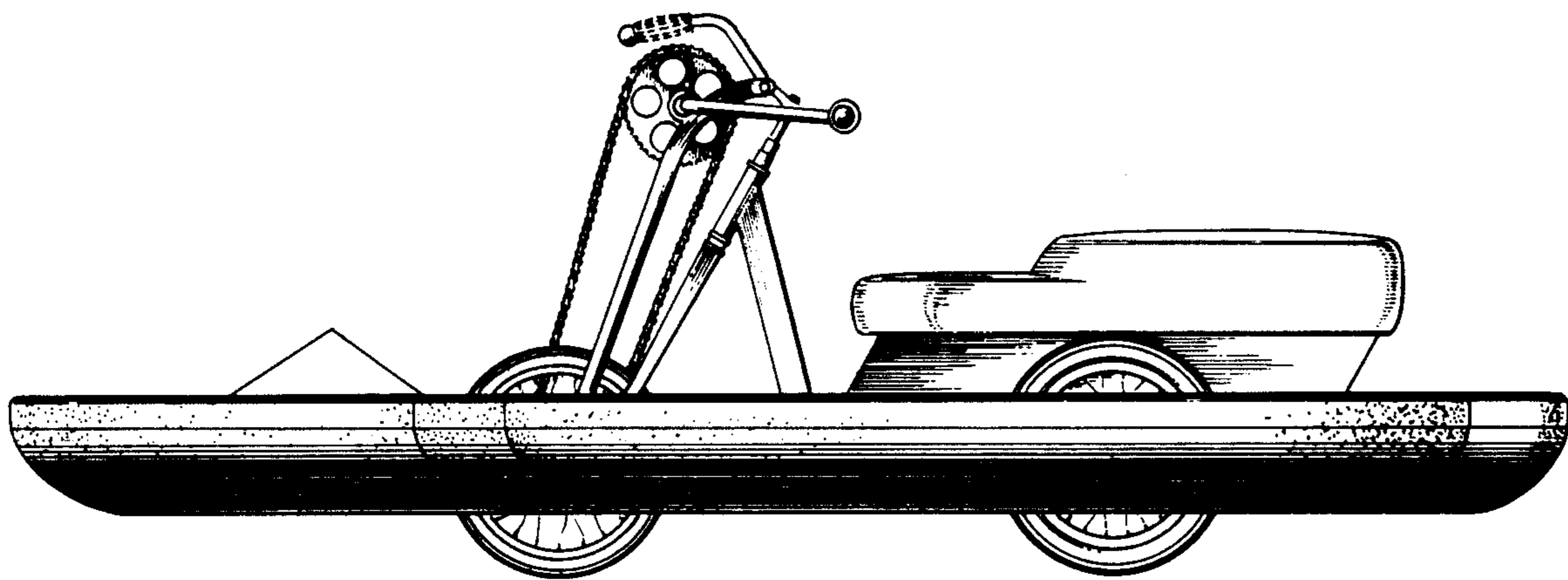
FIG. 2 is a front view of said vehicle.

FIG. 3 is a rear view of said vehicle.

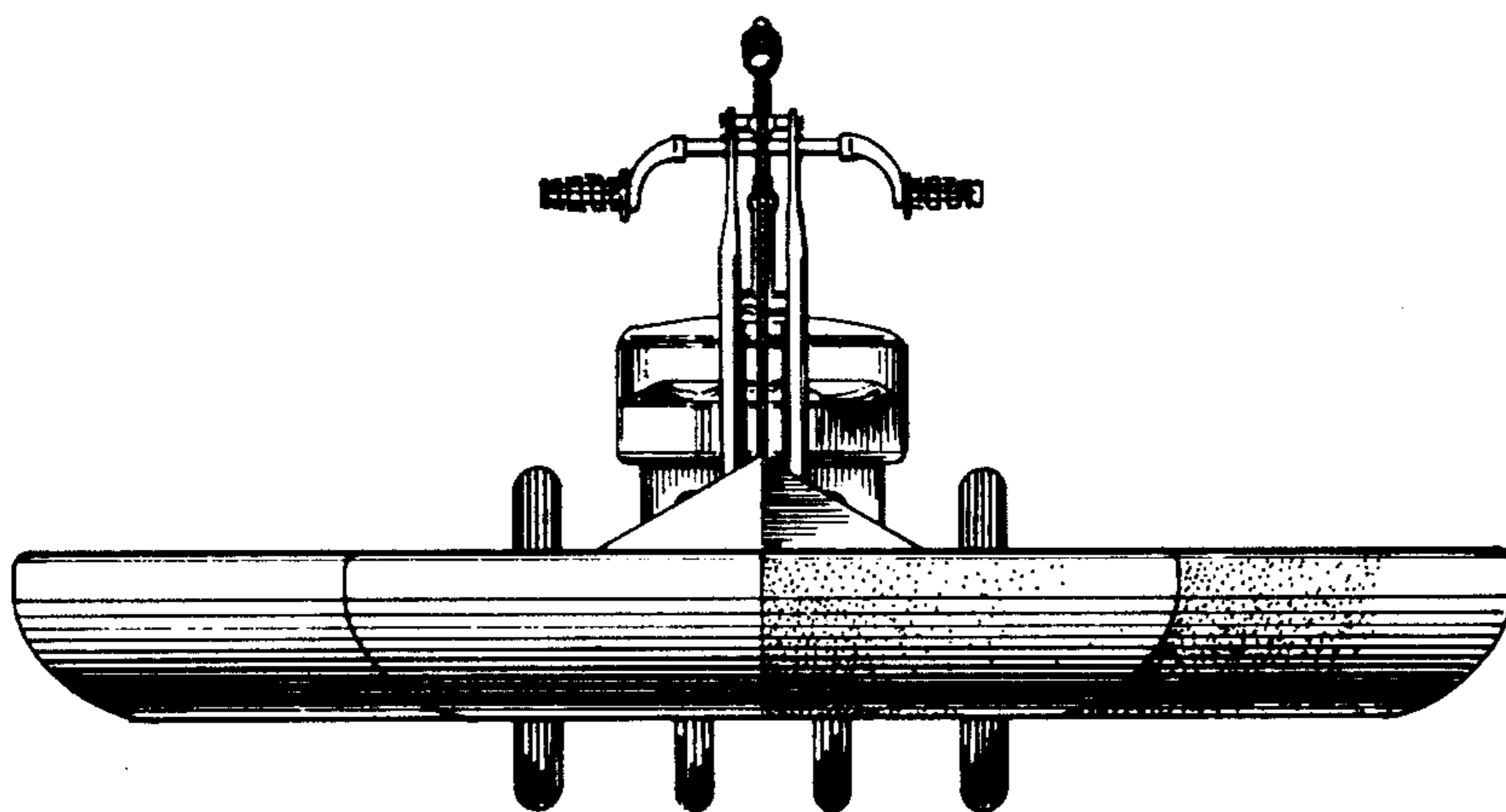
FIG. 4 is a top view of said vehicle.

FIG. 5 is a bottom view of said vehicle.

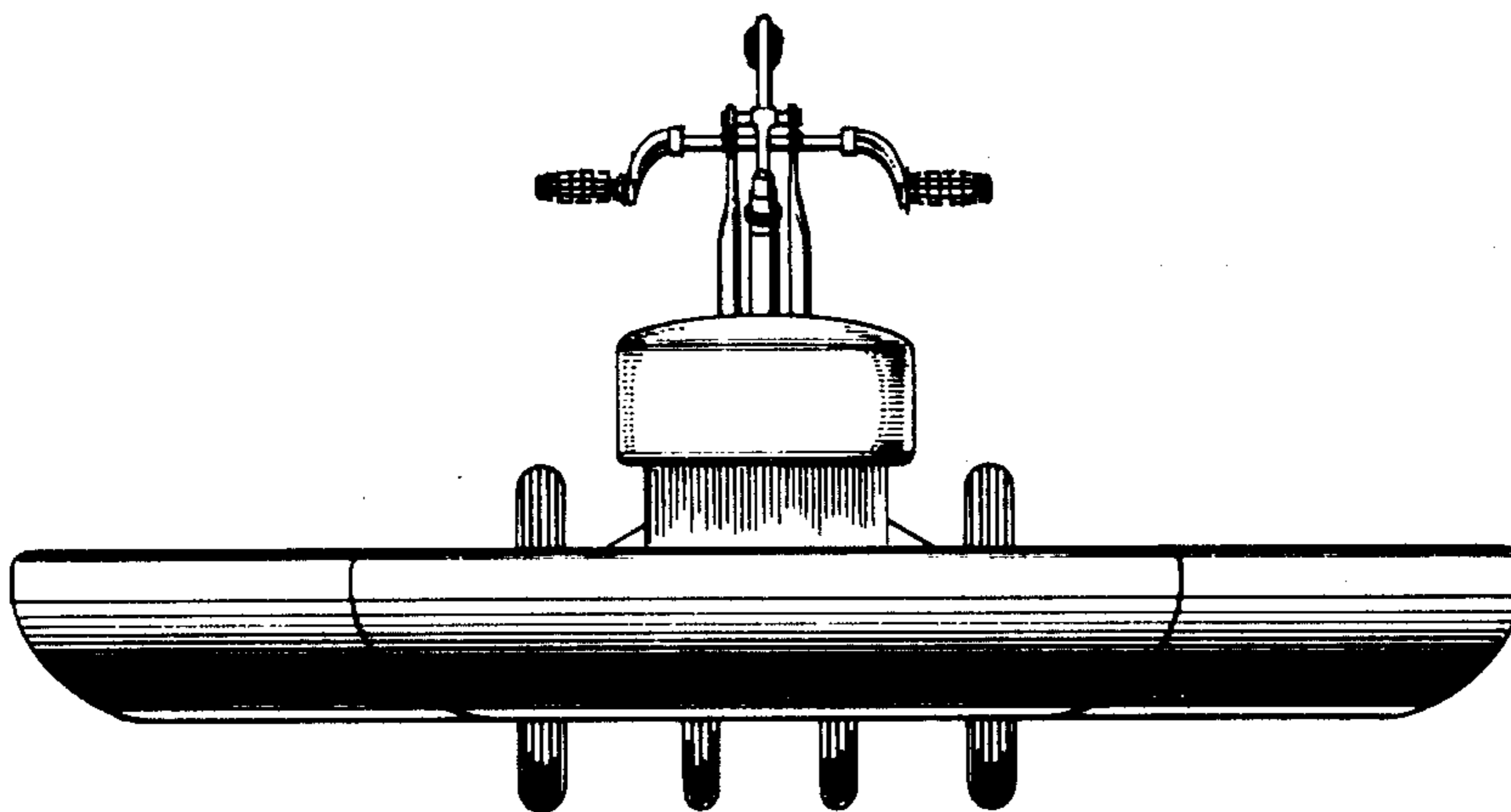




*Fig. 1*

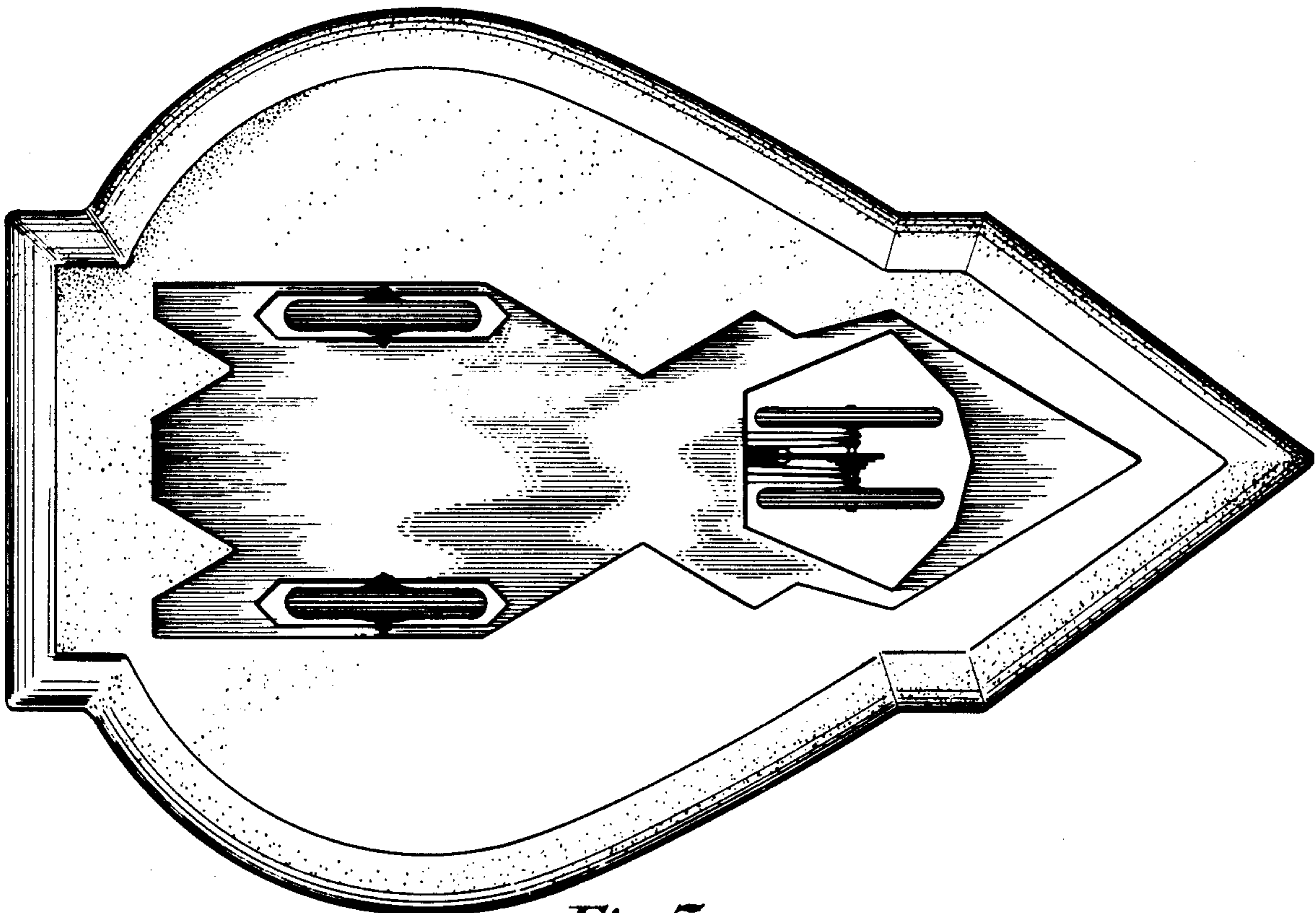
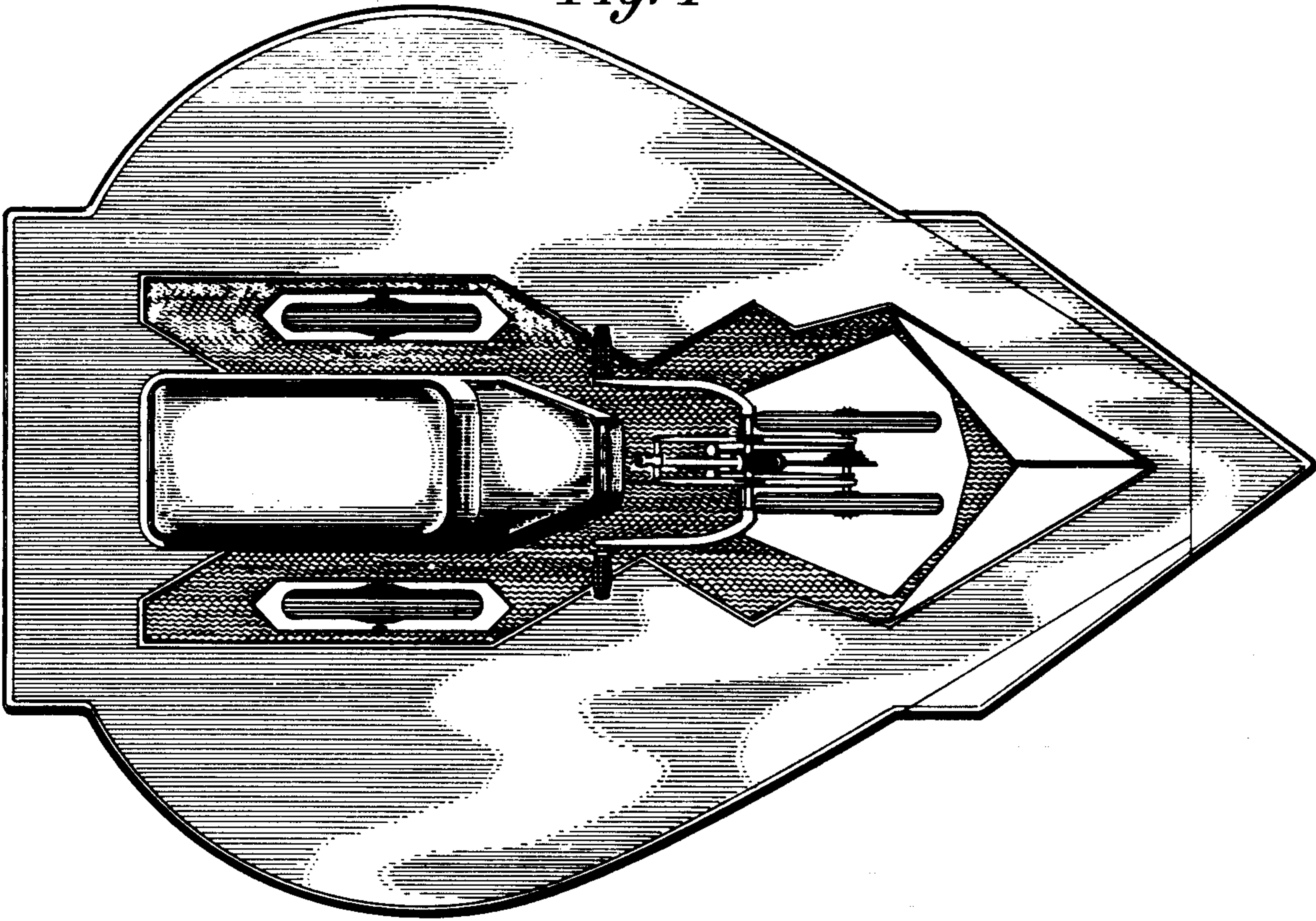


*Fig. 2*



*Fig. 3*

*Fig. 4*



*Fig. 5*