

[54] **TRANSCUTANEOUS ELECTRICAL NERVE STIMULATOR PULSE GENERATOR AND POWER SUPPLY**

D. 246,173	10/1977	Levin .....	D24/36
3,822,708	7/1974	Zilber .....	128/419 R
3,841,305	10/1974	Hallgren .....	128/419 R X
4,066,085	1/1978	Hess .....	128/419 P X

[75] Inventors: **Richard L. Walus**, Columbia Heights; **Ronald N. Kannas**; **Michael H. Cave**, both of Minneapolis, all of Minn.

*Primary Examiner*—Bernard Ansher  
*Attorney, Agent, or Firm*—Leonard P. Prusak

[73] Assignee: **Stimtech, Inc.**, Minneapolis, Minn.

[57] **CLAIM**

[\*\*] Term: **14 Years**

An ornamental design for a transcutaneous electrical nerve stimulator pulse generator and power supply, as shown and described.

[21] Appl. No.: **917,712**

**DESCRIPTION**

[22] Filed: **Jun. 21, 1978**

[51] Int. Cl. .... **D24-02**

[52] U.S. Cl. .... **D24/41; D24/8; D24/36**

[58] Field of Search ..... 128/419 R, 419 P, 419 E, 128/419 PS, 419 PG; D24/8, 41, 36; D13/32

FIG. 1 is a front elevation of a transcutaneous electrical nerve stimulator pulse generator and power supply showing our new design;  
FIG. 2 is a bottom plan view thereof;  
FIG. 3 is a right end elevation thereof;  
FIG. 4 is a top plan view thereof;  
FIG. 5 is a left end elevation thereof;  
FIG. 6 is a rear elevation thereof;  
FIG. 7 is a front elevation of a modified embodiment of the design illustrated in FIG. 1;  
FIG. 8 is a top plan view thereof; and  
FIG. 9 is a bottom plan view thereof.

[56] **References Cited**

**U.S. PATENT DOCUMENTS**

D. 211,840	7/1968	Leverenz et al. ....	D24/41
D. 229,111	11/1973	Avery .....	D24/8
D. 240,463	7/1976	Jordan .....	D24/8

Fig 1

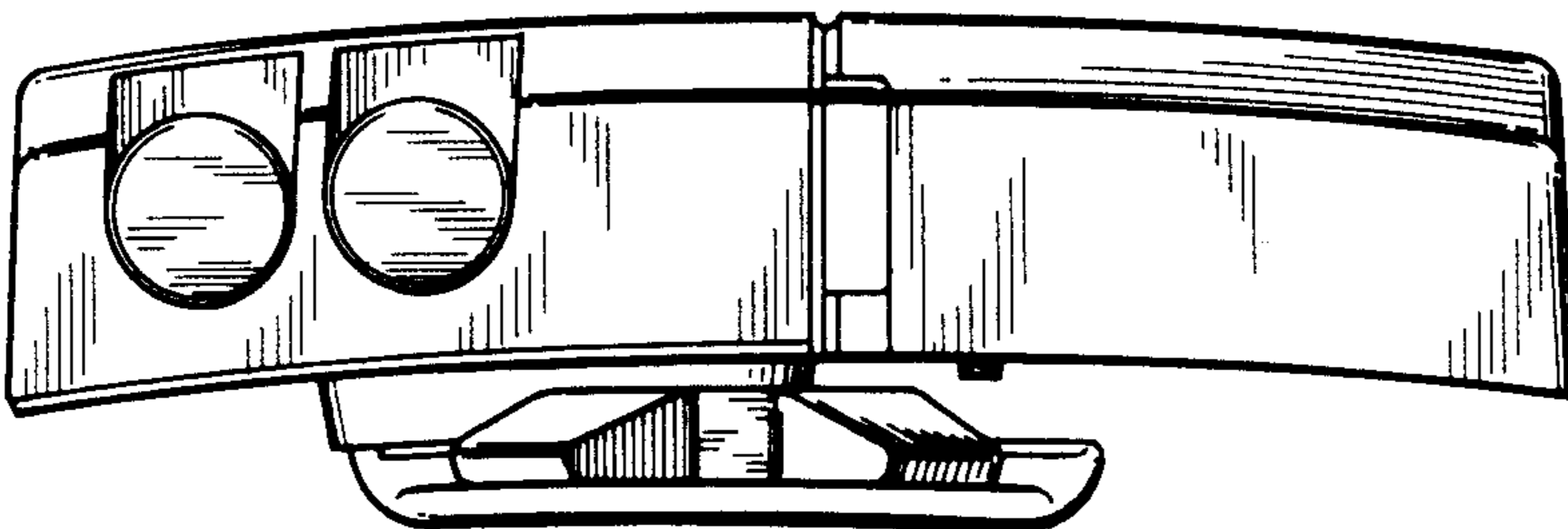
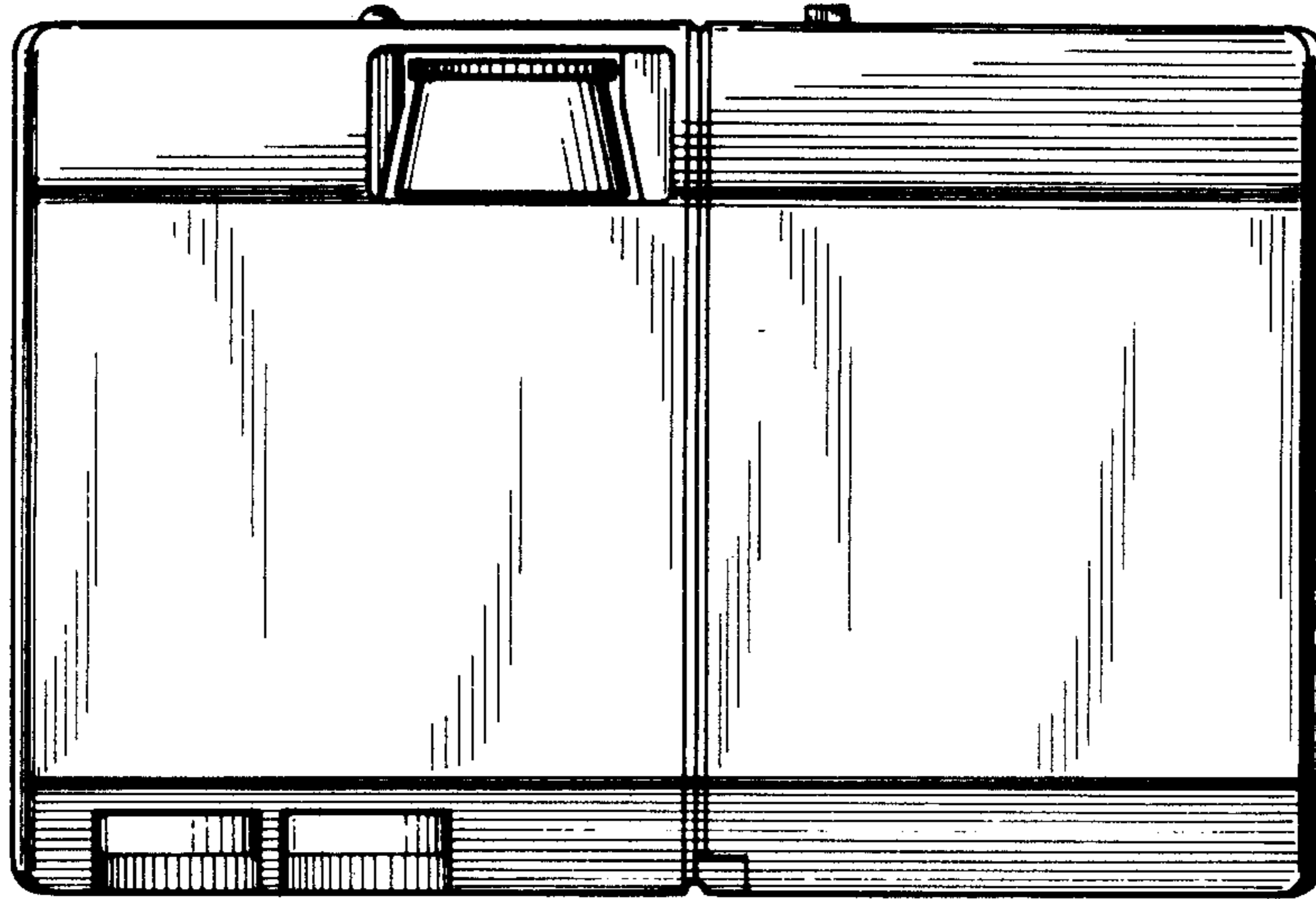

Fig. 3.

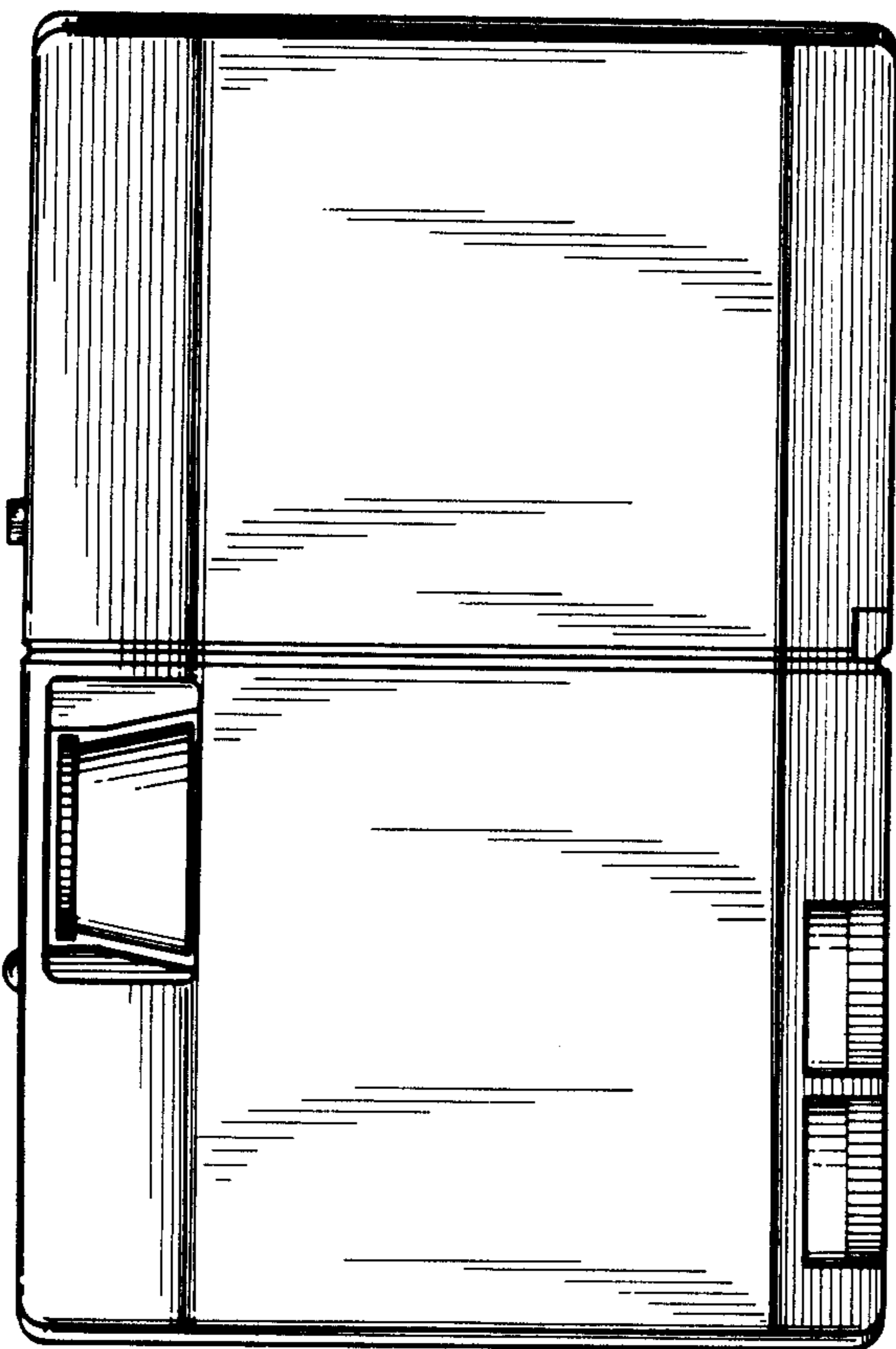
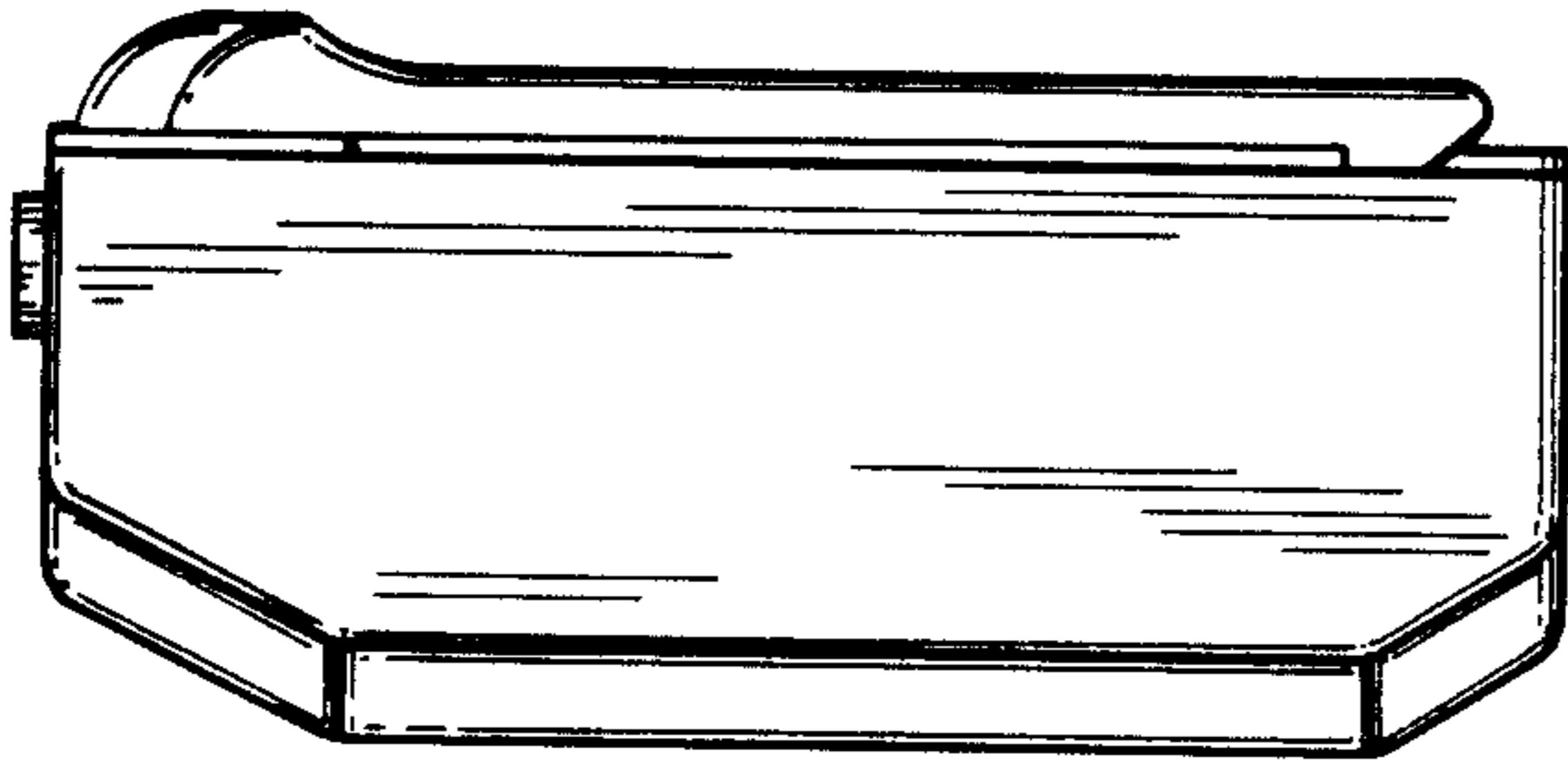

Fig. 1.

Fig. 2.

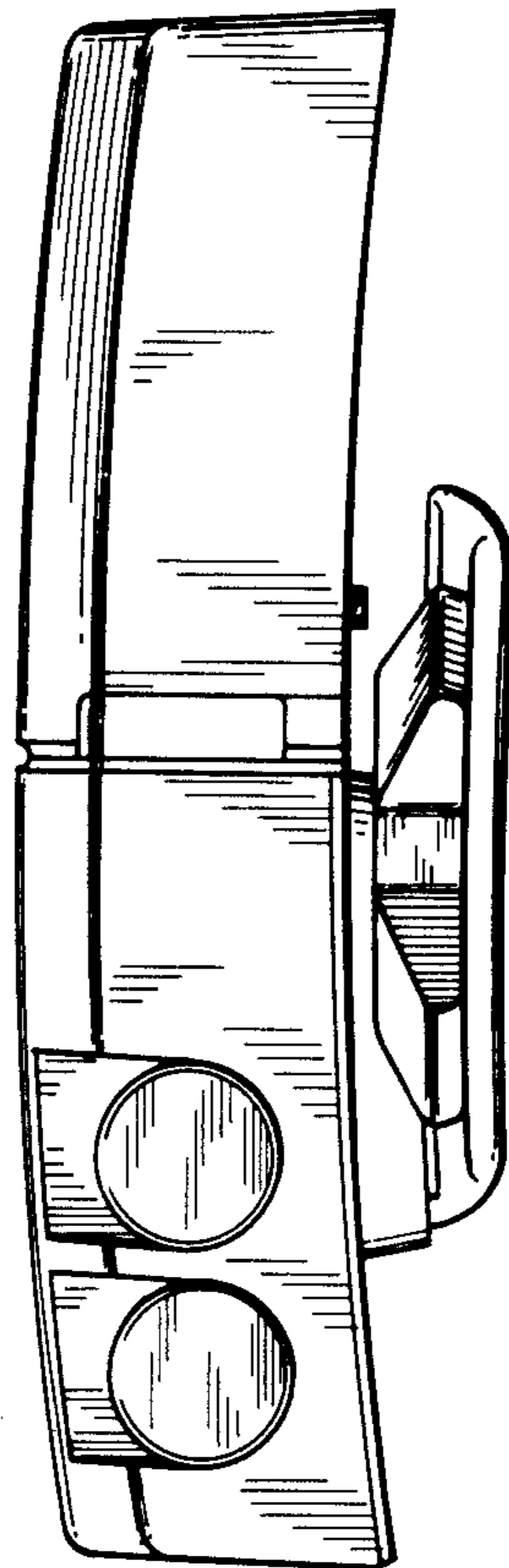

Fig. 4

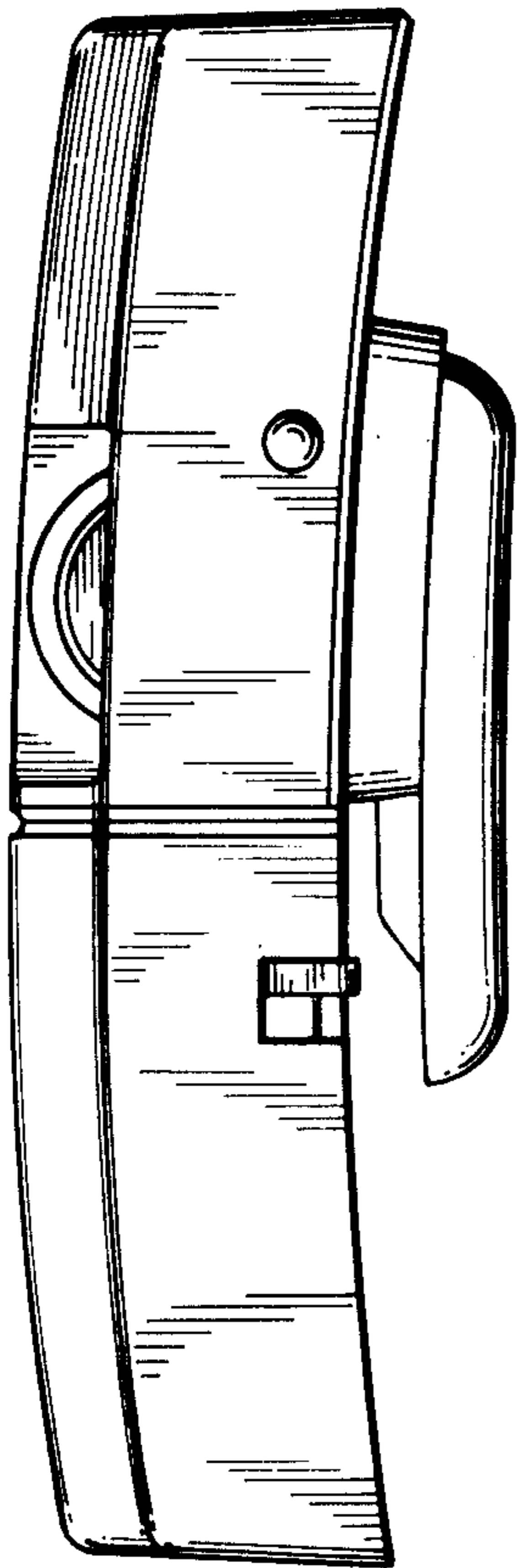

Fig. 5

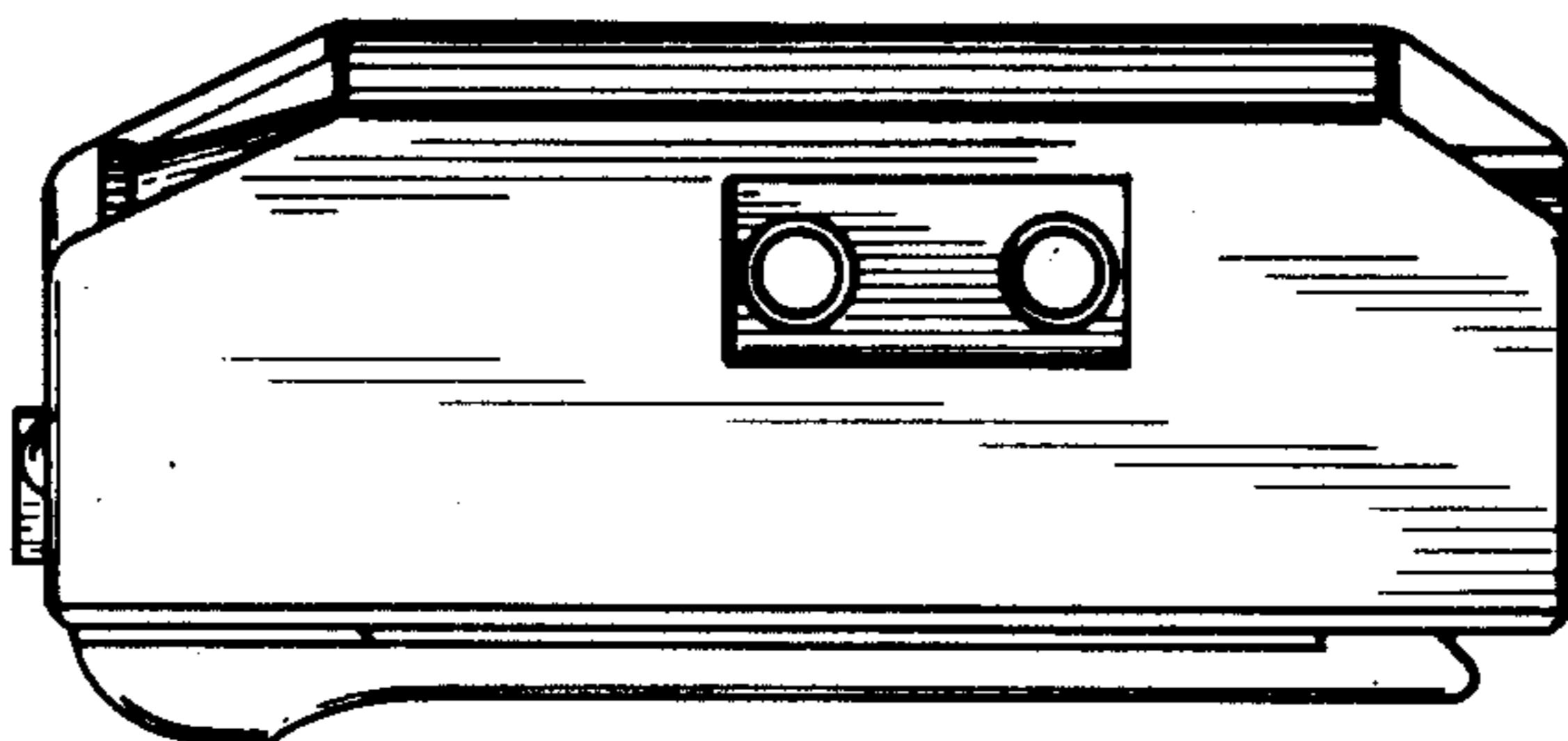

Fig. 6

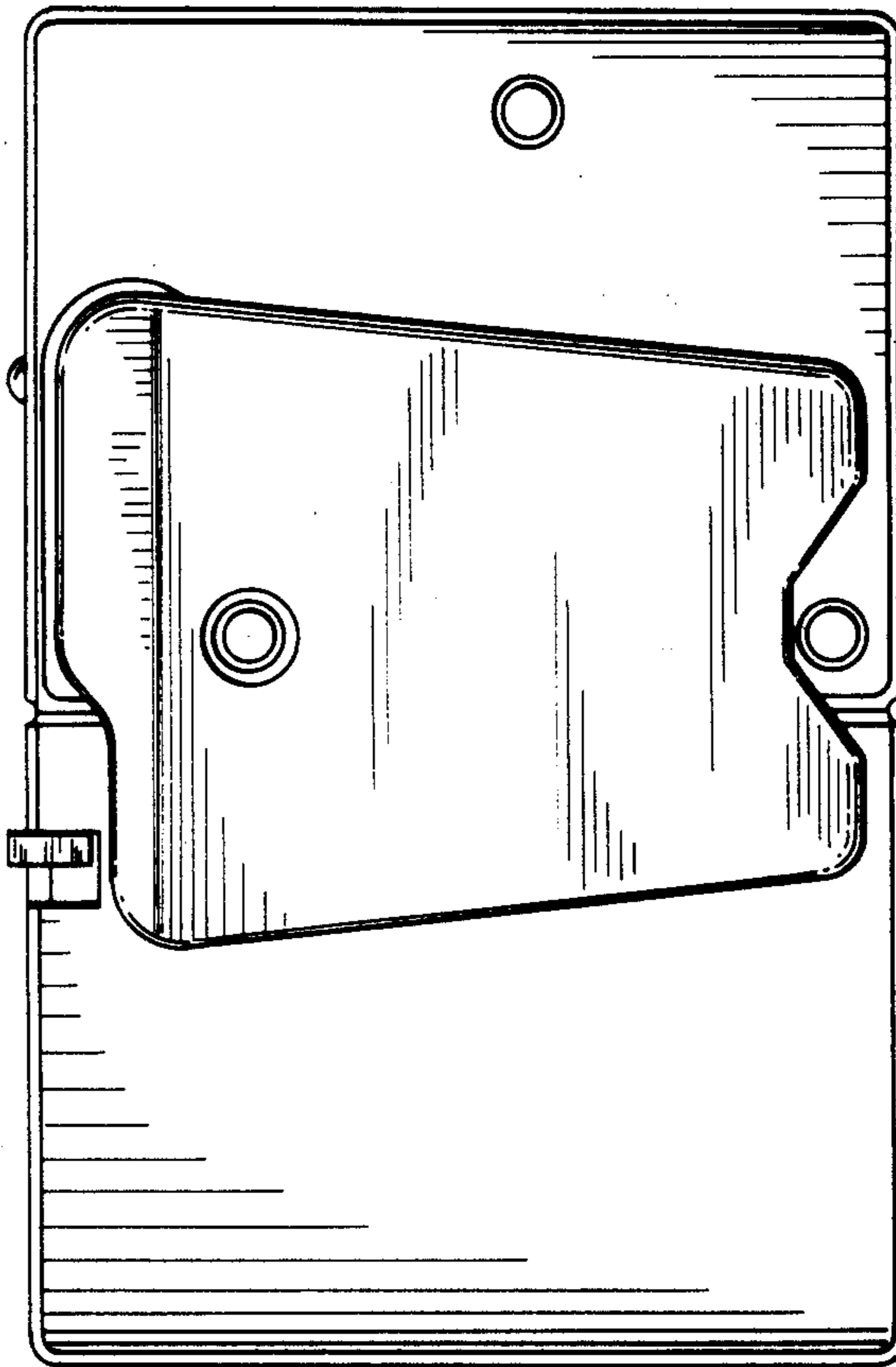

Fig. 7.

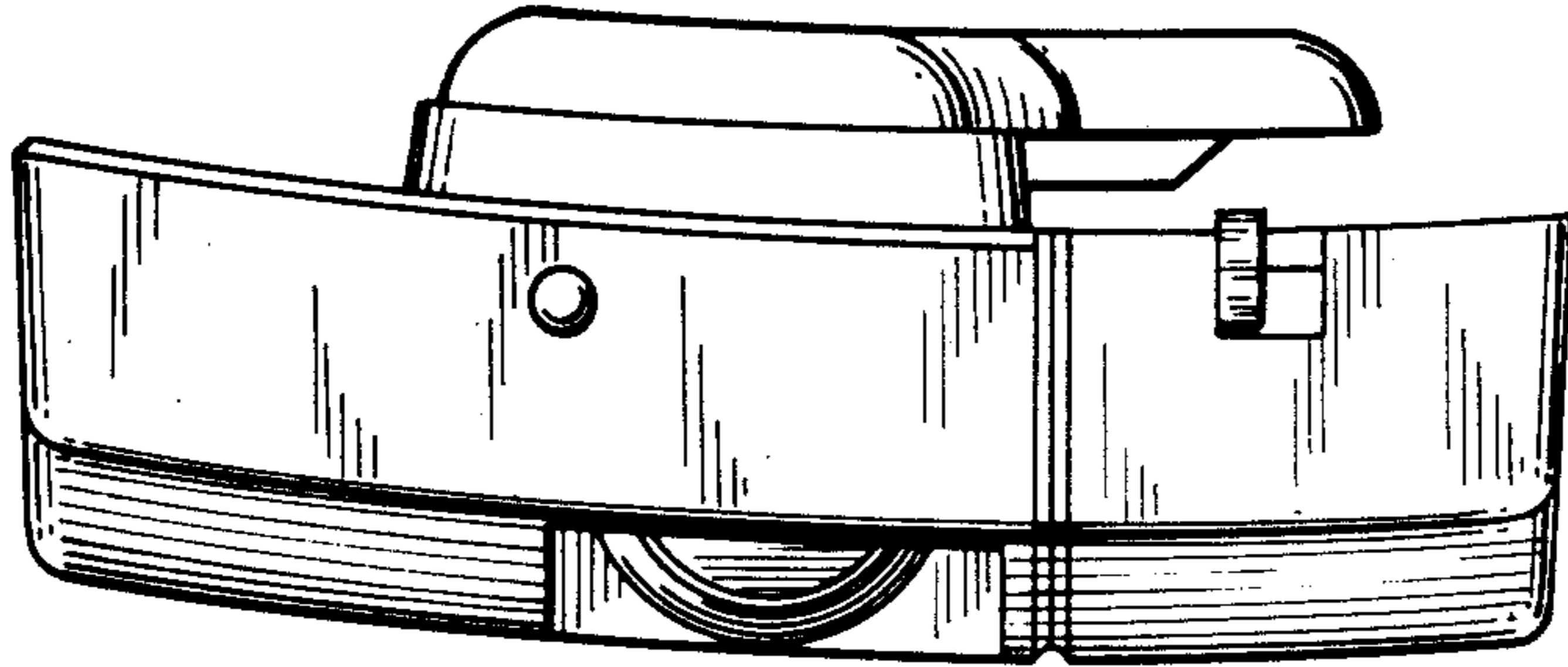

Fig. 8.

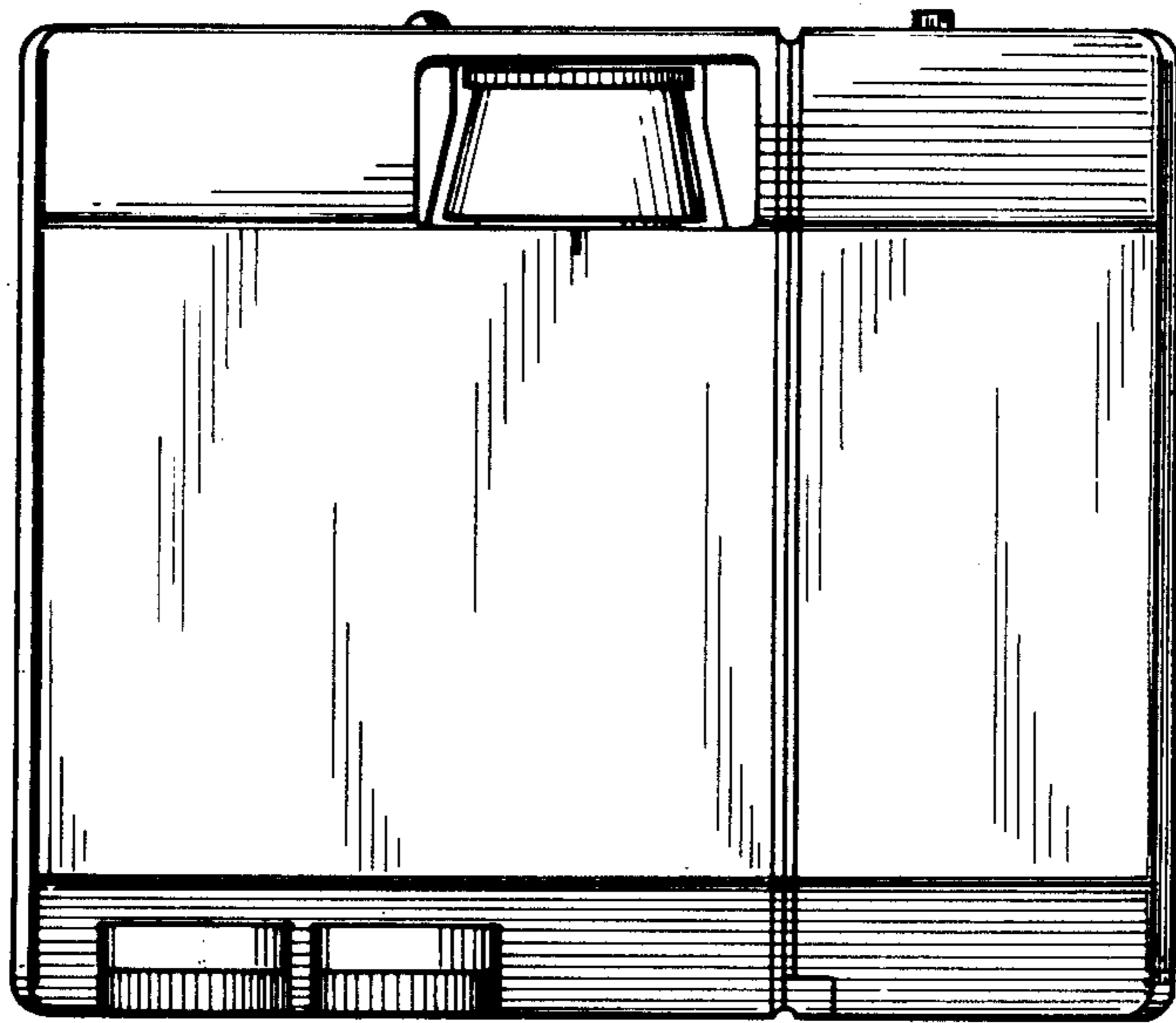

Fig. 9.

