

[54] HYDROPONIC UNIT

[76] Inventor: **Stuart B. Schneck**, 766 Teresita Blvd., San Francisco, Calif. 94127

[\*\*] Term: **14 Years**

[21] Appl. No.: **909,711**

[22] Filed: **May 25, 1978**

[51] Int. Cl. .... **D11-02**

[52] U.S. Cl. .... **D11/156**

[58] Field of Search ..... **D11/143-149, D11/151-156, 164; 47/1 R, 4, 14, 16, 41 R, 41 SS, 33, 55, 61, 66-69, 71, 72, 83, 85-87, 79, 81**

**References Cited**

**U.S. PATENT DOCUMENTS**

D. 243,113	1/1977	Hirsch .....	D11/156
D. 247,357	2/1978	Gray .....	D11/156
3,082,575	3/1963	Schulz .....	D11/156
4,057,930	11/1977	Barham .....	47/61

**OTHER PUBLICATIONS**

"Hydroponics", Brochure—Homeland Industries, p. 3, 2.5 ft. Module Hydroponic Unit.

*Primary Examiner*—Wallace R. Burke

*Assistant Examiner*—B. J. Bullock

*Attorney, Agent, or Firm*—Stephen S. Townsend

[57] **CLAIM**

The ornamental design for a hydroponic unit, as shown and described.

**DESCRIPTION**

FIG. 1 is an enlarged perspective view of a hydroponic unit showing my new design.

FIG. 2 is a top view thereof.

FIG. 3 is a bottom view thereof.

FIG. 4 is a front elevational view thereof.

FIG. 5 is a back elevational view thereof.

FIG. 6 is a side elevational view taken from the left of FIG. 1;

FIG. 7 is a side elevational view taken from the right of FIG. 1.

FIG. 8 is an enlarged sectional view taken in the direction of the arrows on line 8—8 of FIG. 2.

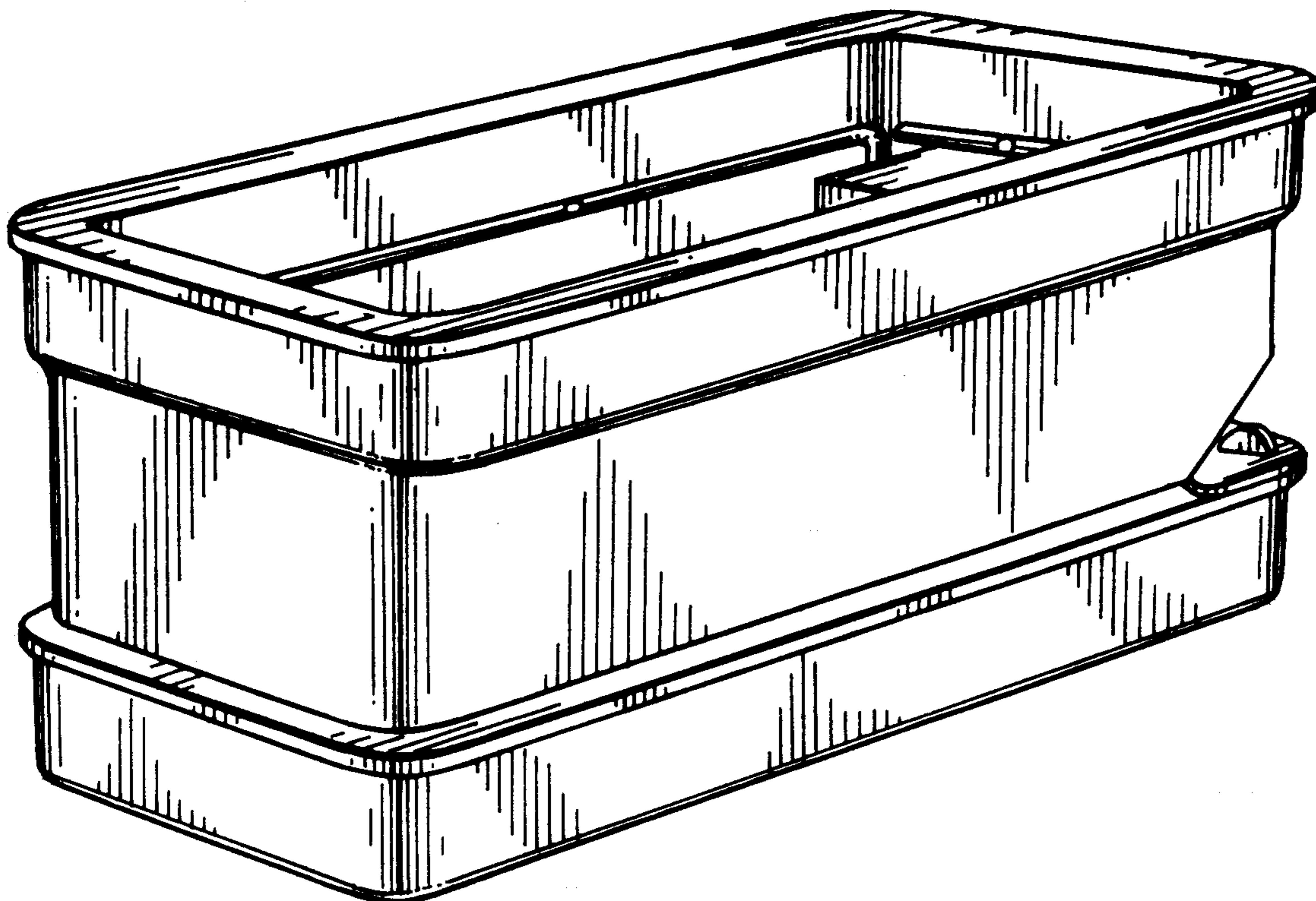

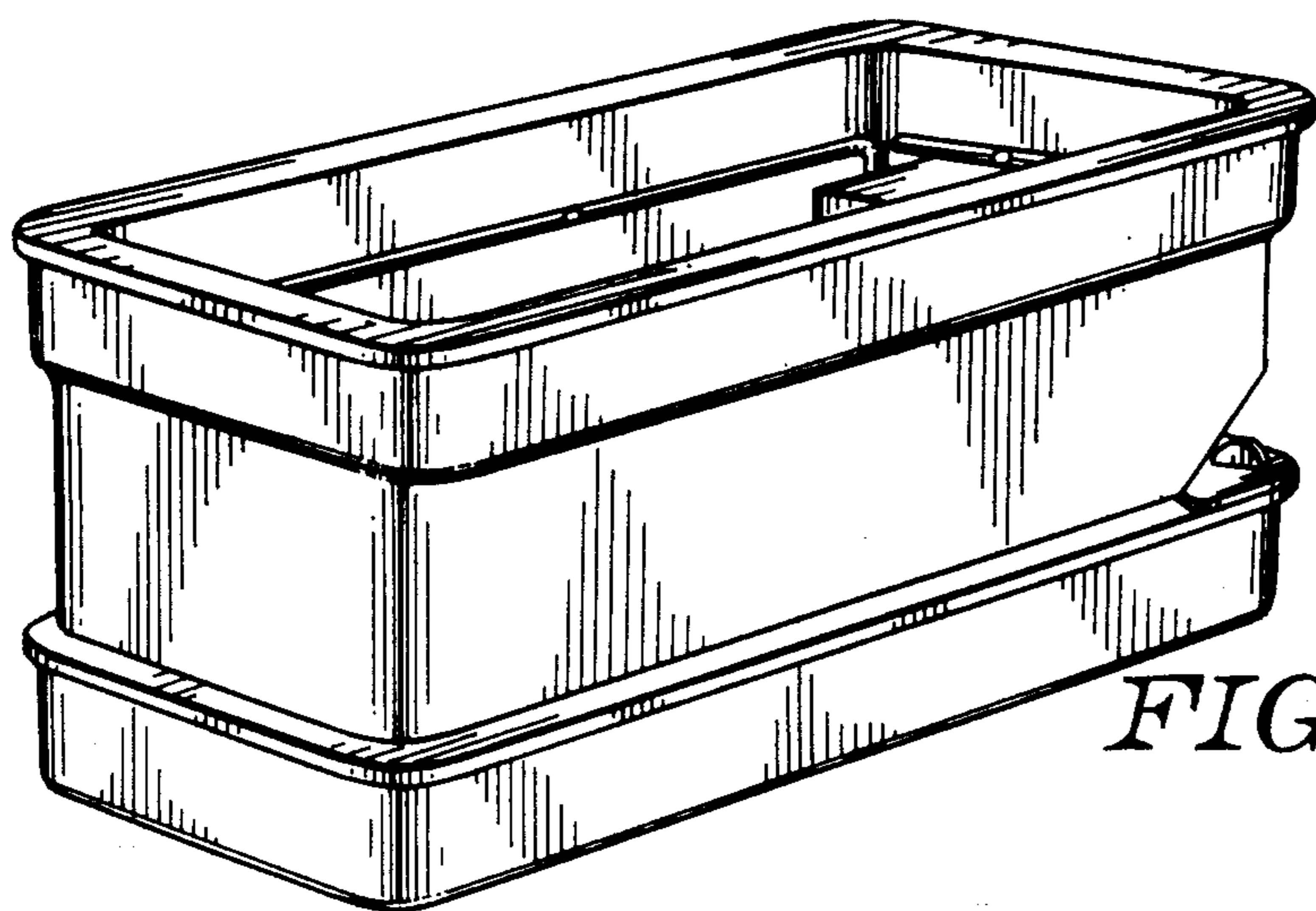

FIG. 1

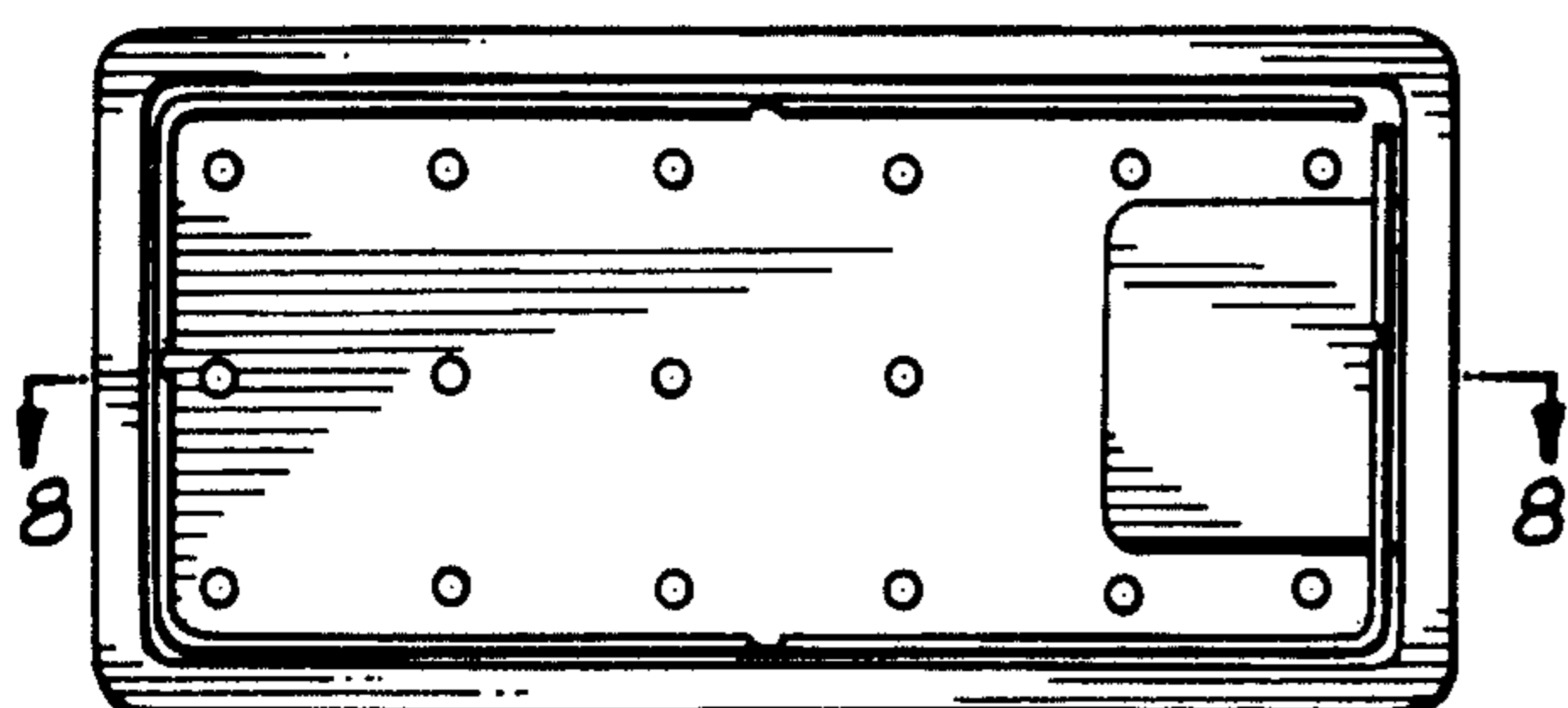

FIG. 2

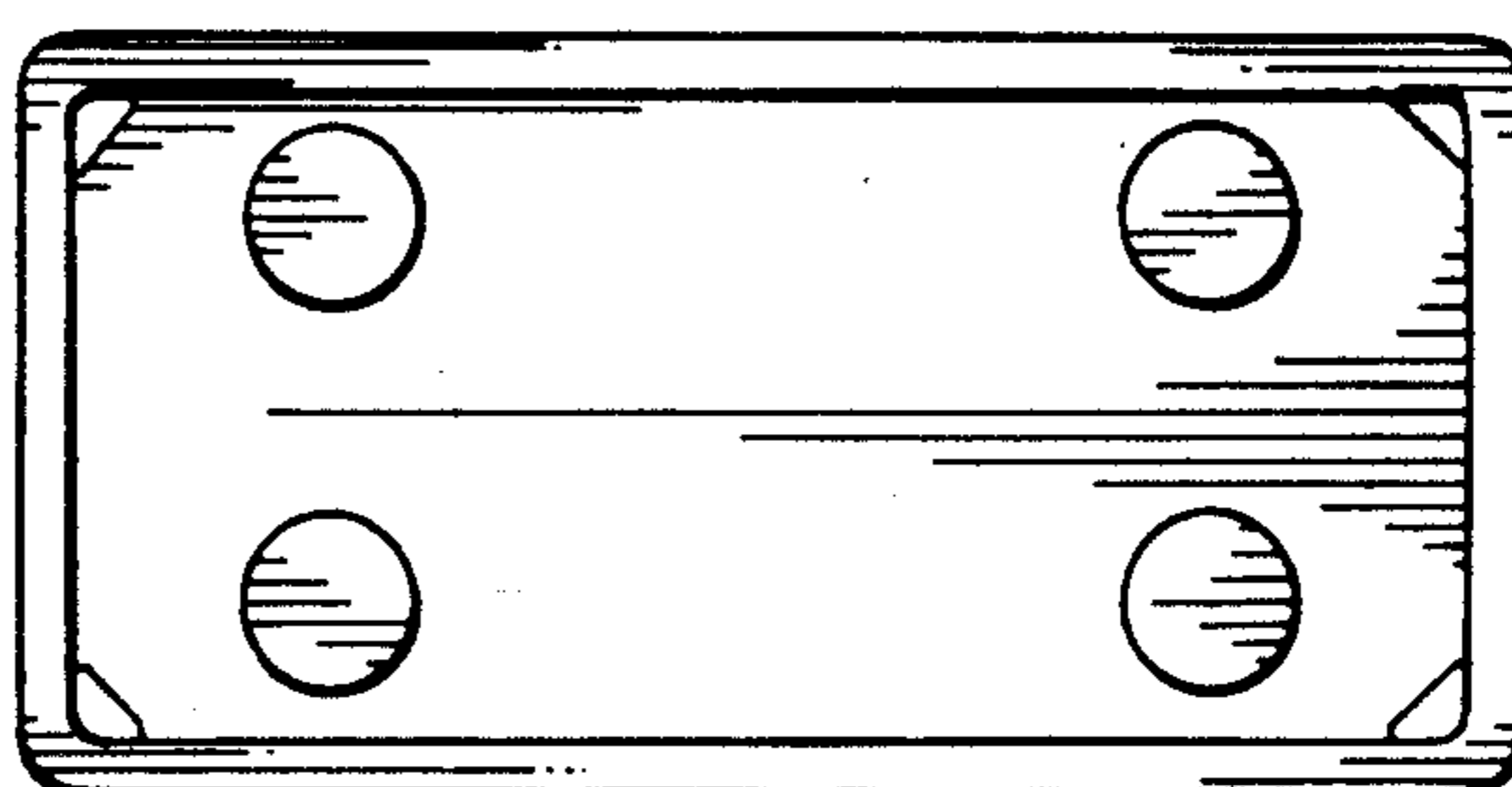

FIG. 3

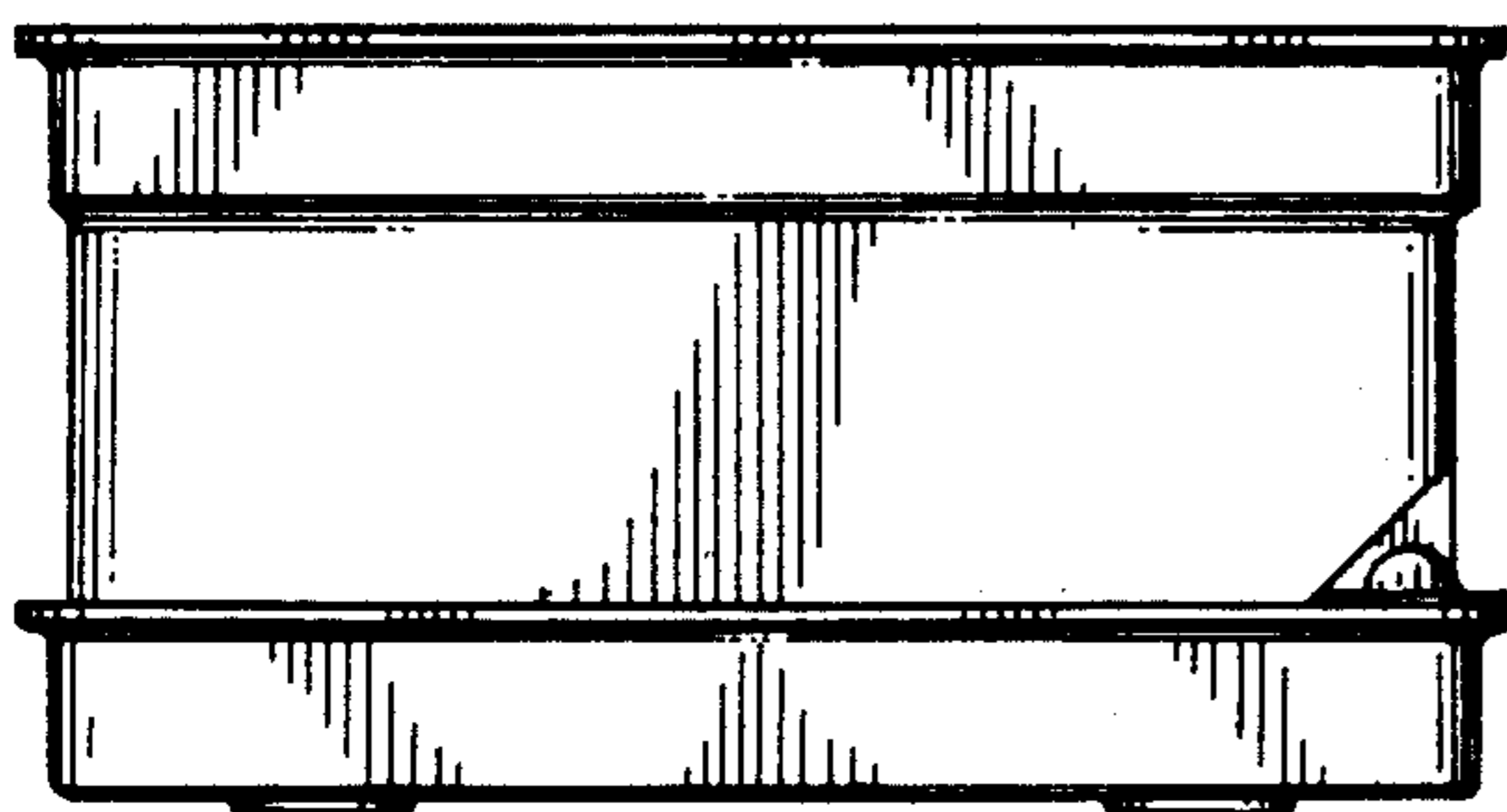

FIG. 4

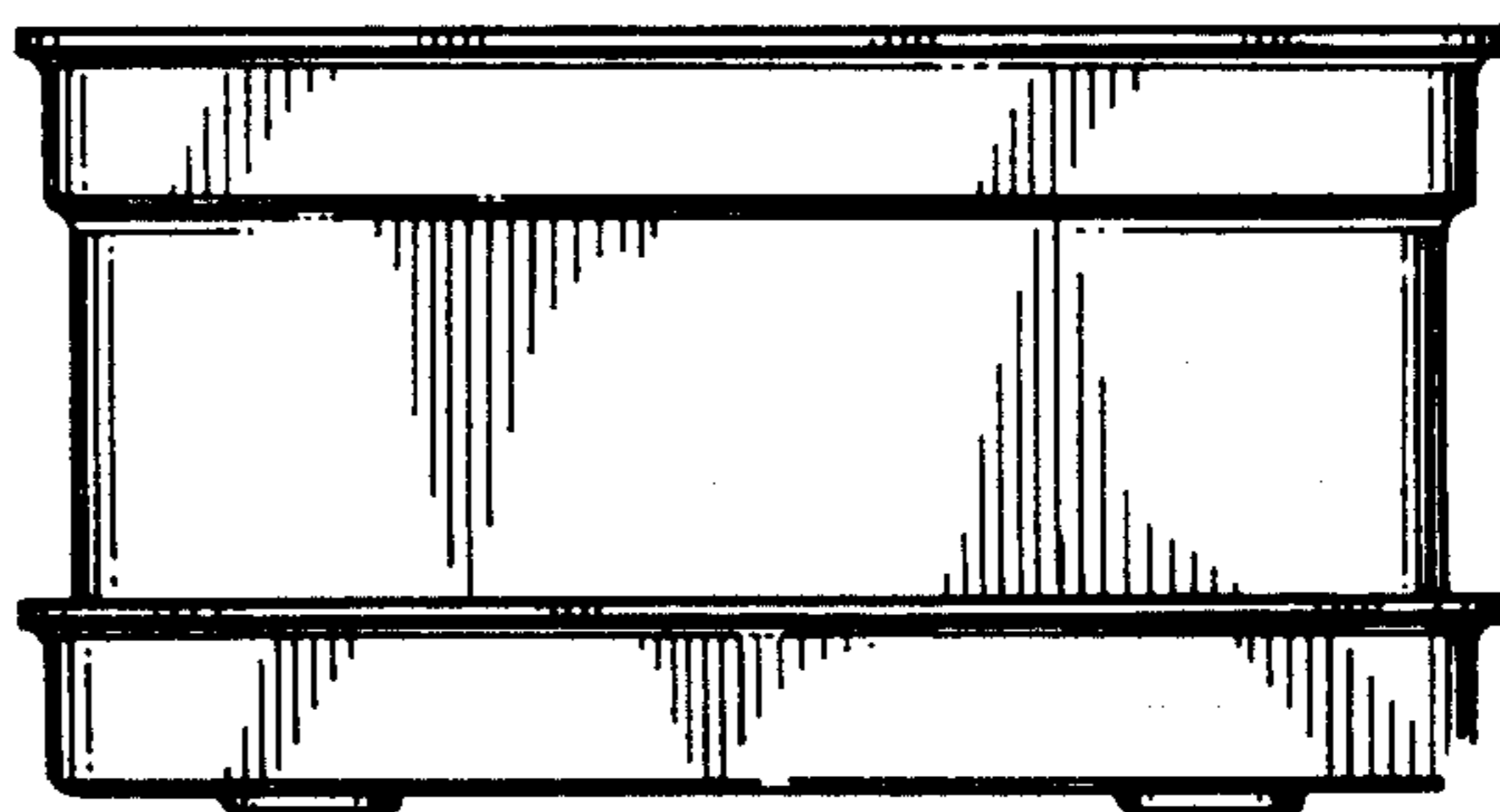

FIG. 5

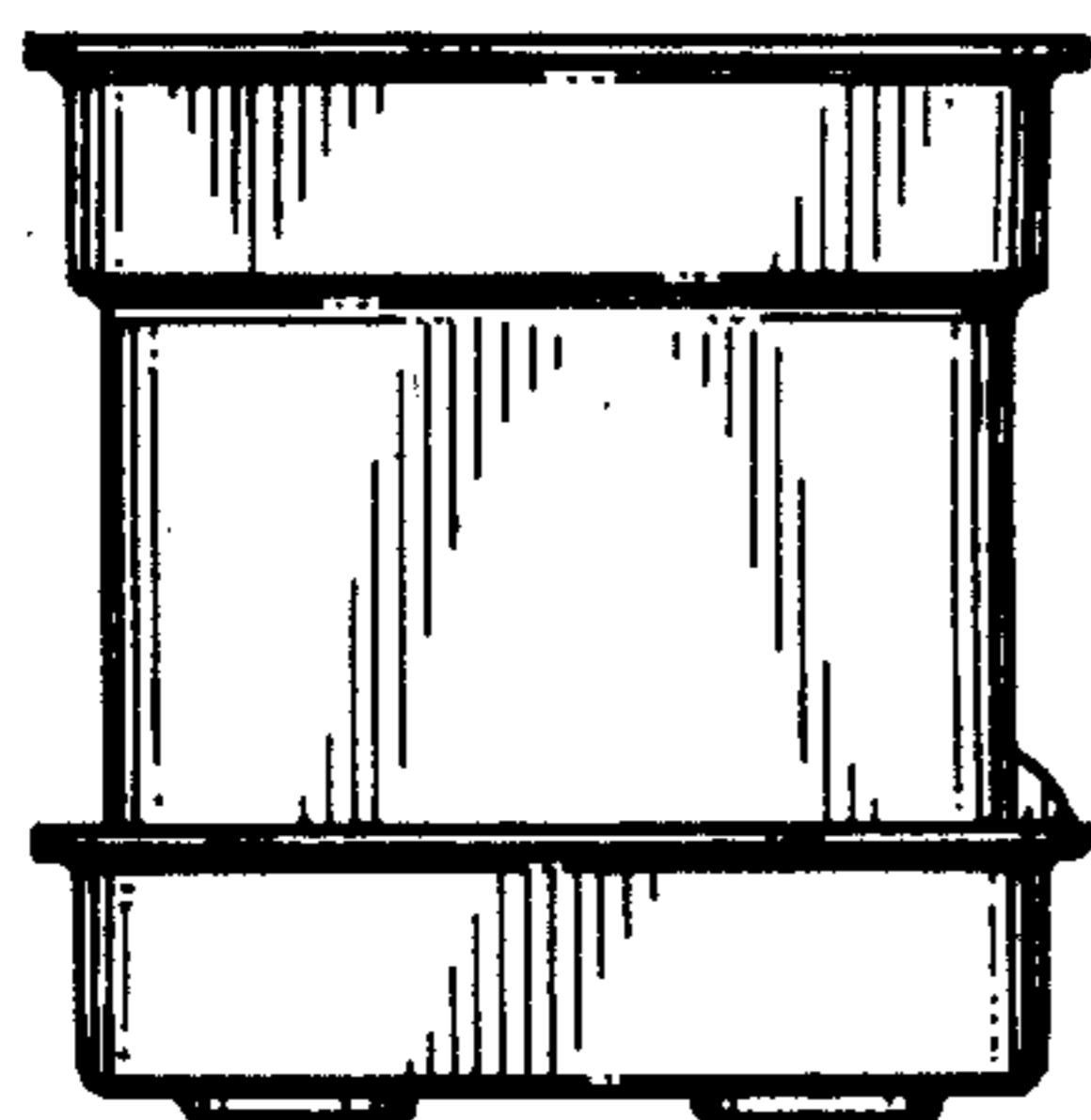

FIG. 6

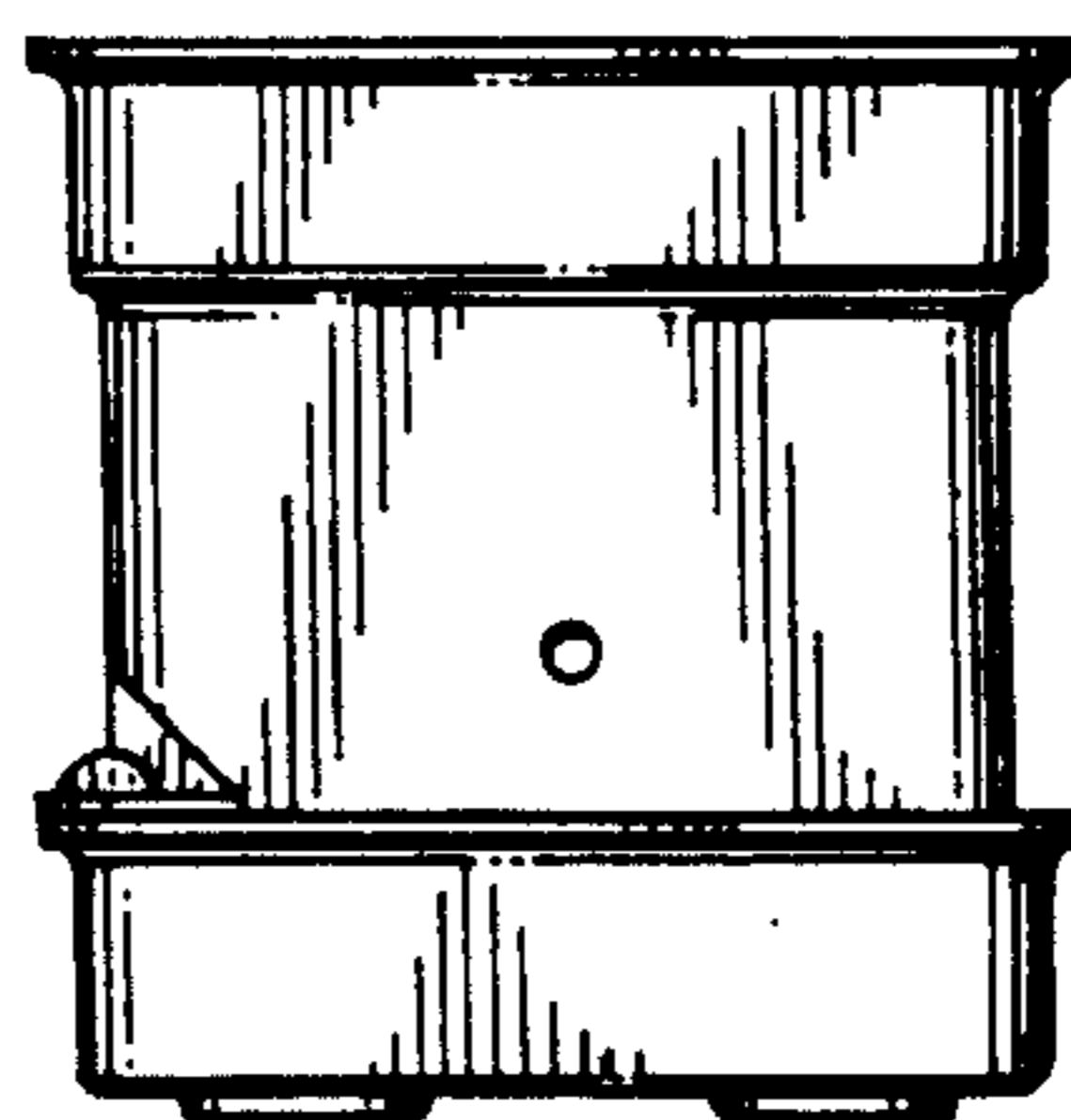

FIG. 7

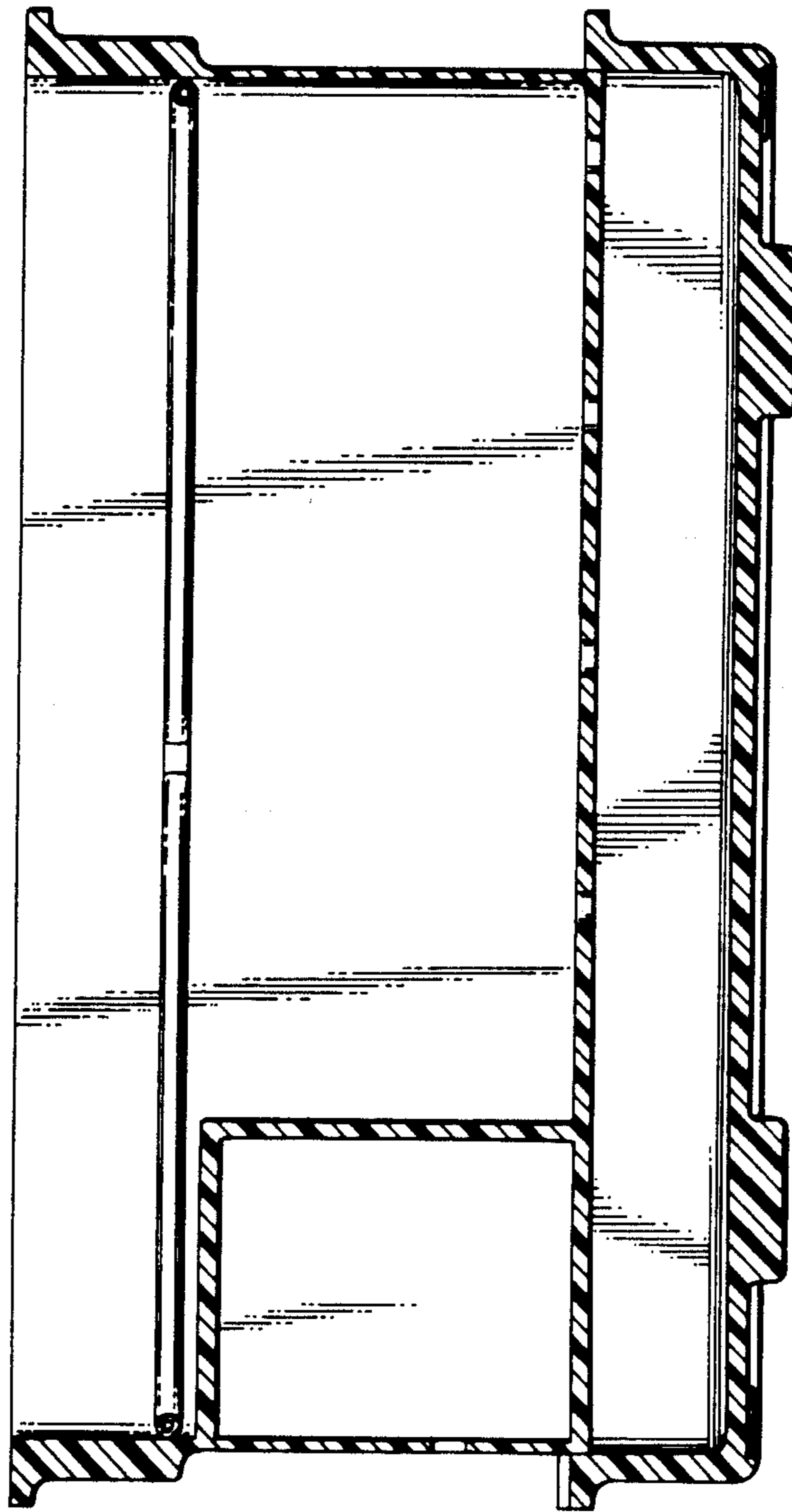

FIG. 8