

[54] COMBINED BOAT STEERING WHEEL AND SUPPORT COLUMN

[75] Inventor: Mario Cura', Turin, Italy

[73] Assignee: A.T.N. S.p.A., Turin, Italy

[\*\*] Term: 14 Years

[21] Appl. No.: 850,527

[22] Filed: Nov. 10, 1977

[30] Foreign Application Priority Data

May 17, 1977 [IT] Italy ..... 53170 B/77

May 17, 1977 [IT] Italy ..... 53171 B/77

[51] Int. Cl. .... D12-16

[52] U.S. Cl. .... D12/70

[58] Field of Search ..... D12/70, 176; 114/144 R, 114/160

[56] References Cited

U.S. PATENT DOCUMENTS

3,815,537 6/1974 Evans ..... 114/144 R

Primary Examiner—Sam Rosen

Attorney, Agent, or Firm—Leonard J. Robbins

[57] CLAIM

The ornamental design for a combined boat steering wheel and support column, as shown and described.

DESCRIPTION

FIG. 1 is a side elevational view of the combined boat steering wheel and support column;

FIG. 2 is a front elevational view thereof; and

FIG. 3 is a perspective view thereof.

The base has been omitted from FIG. 3 for ease of illustration. The portion of the drawings shown in broken lines are for illustrative purposes only and do not form a part of my claimed design.

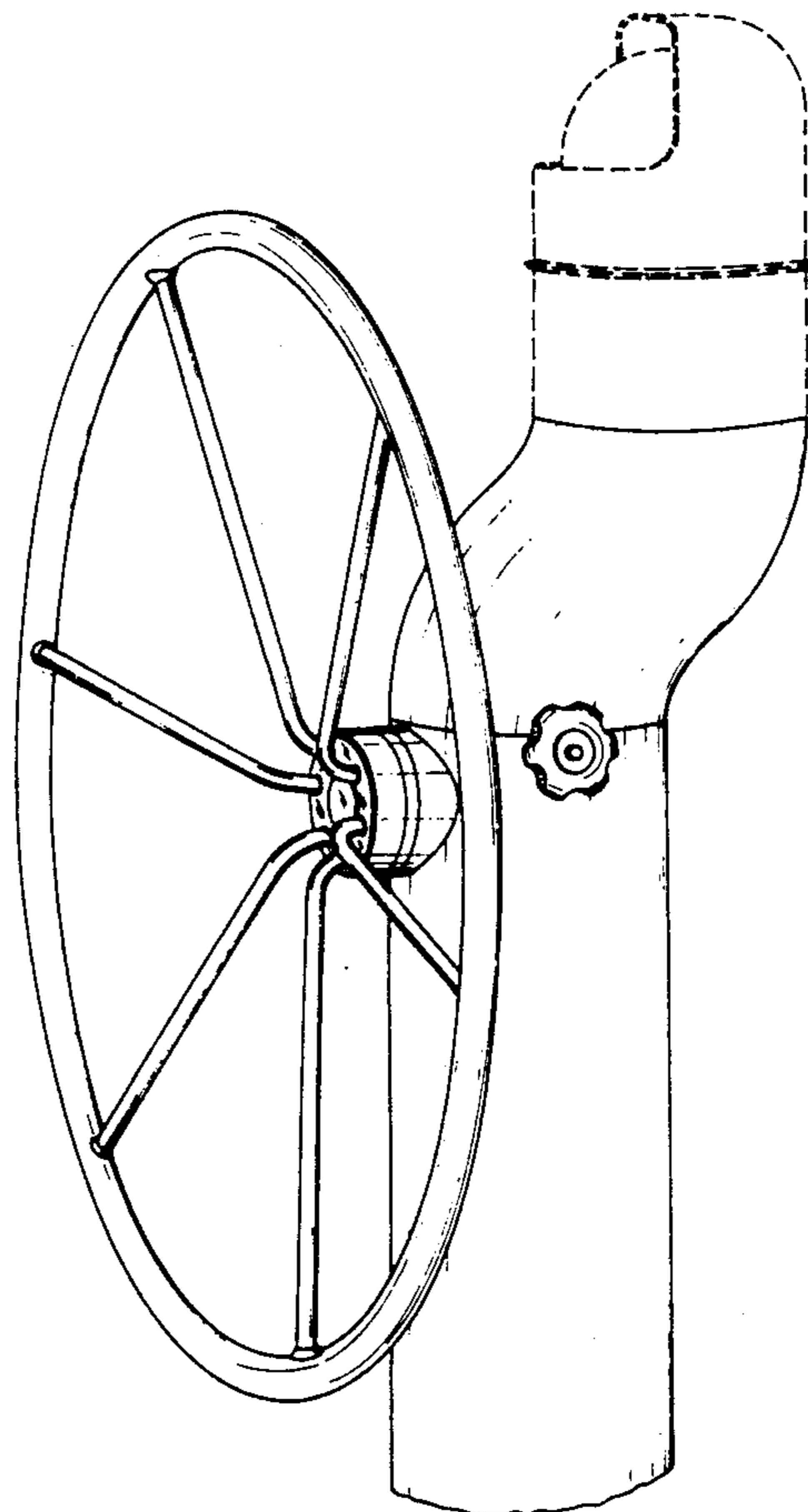

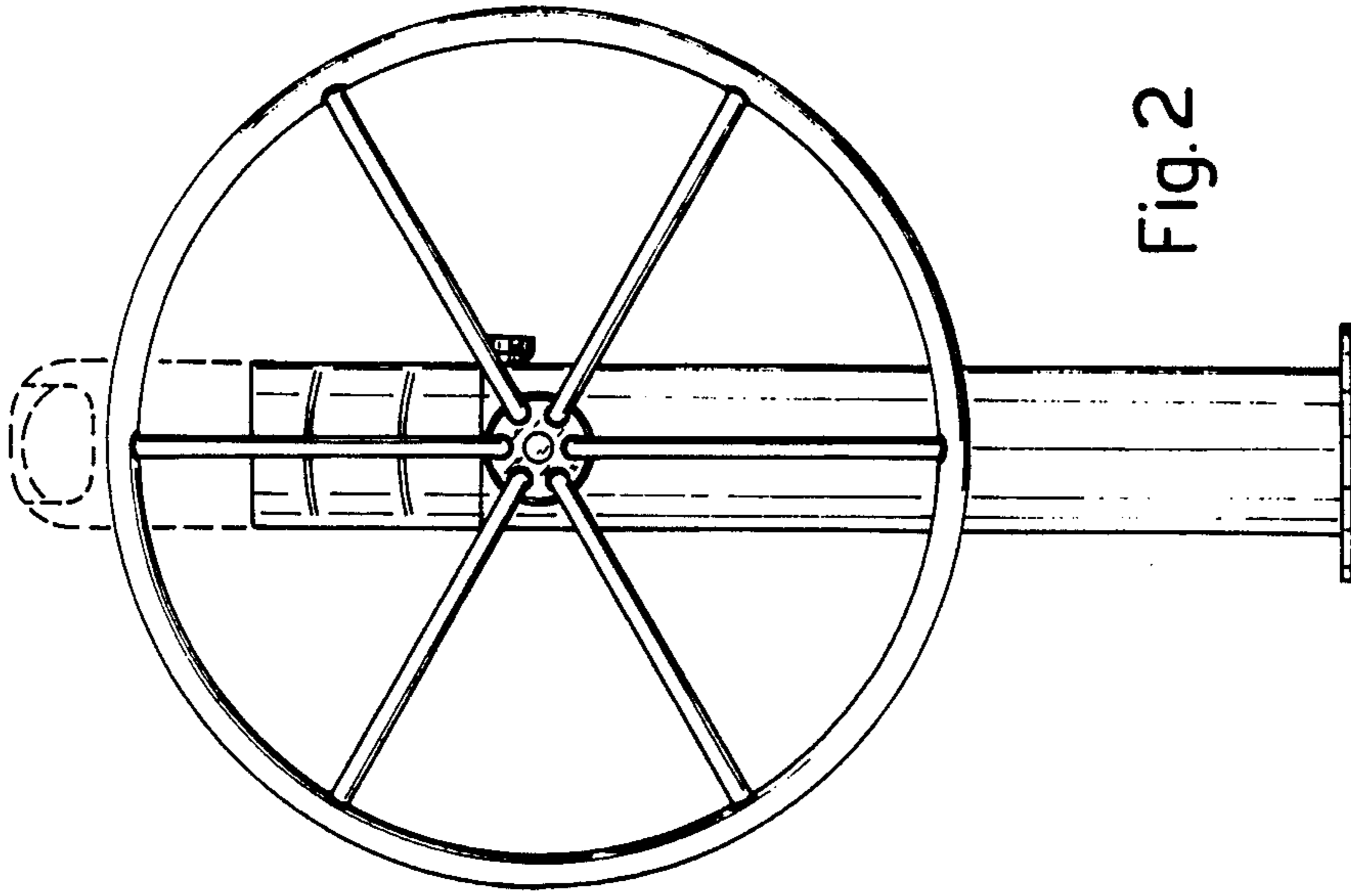

Fig. 2

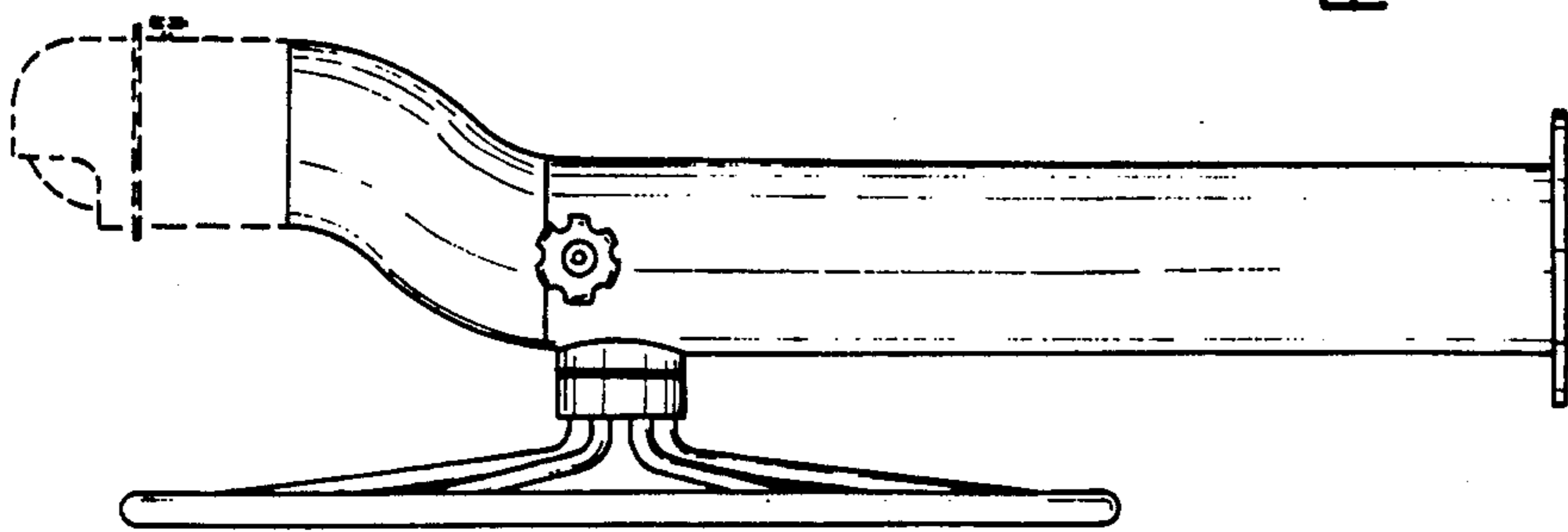

Fig. 1

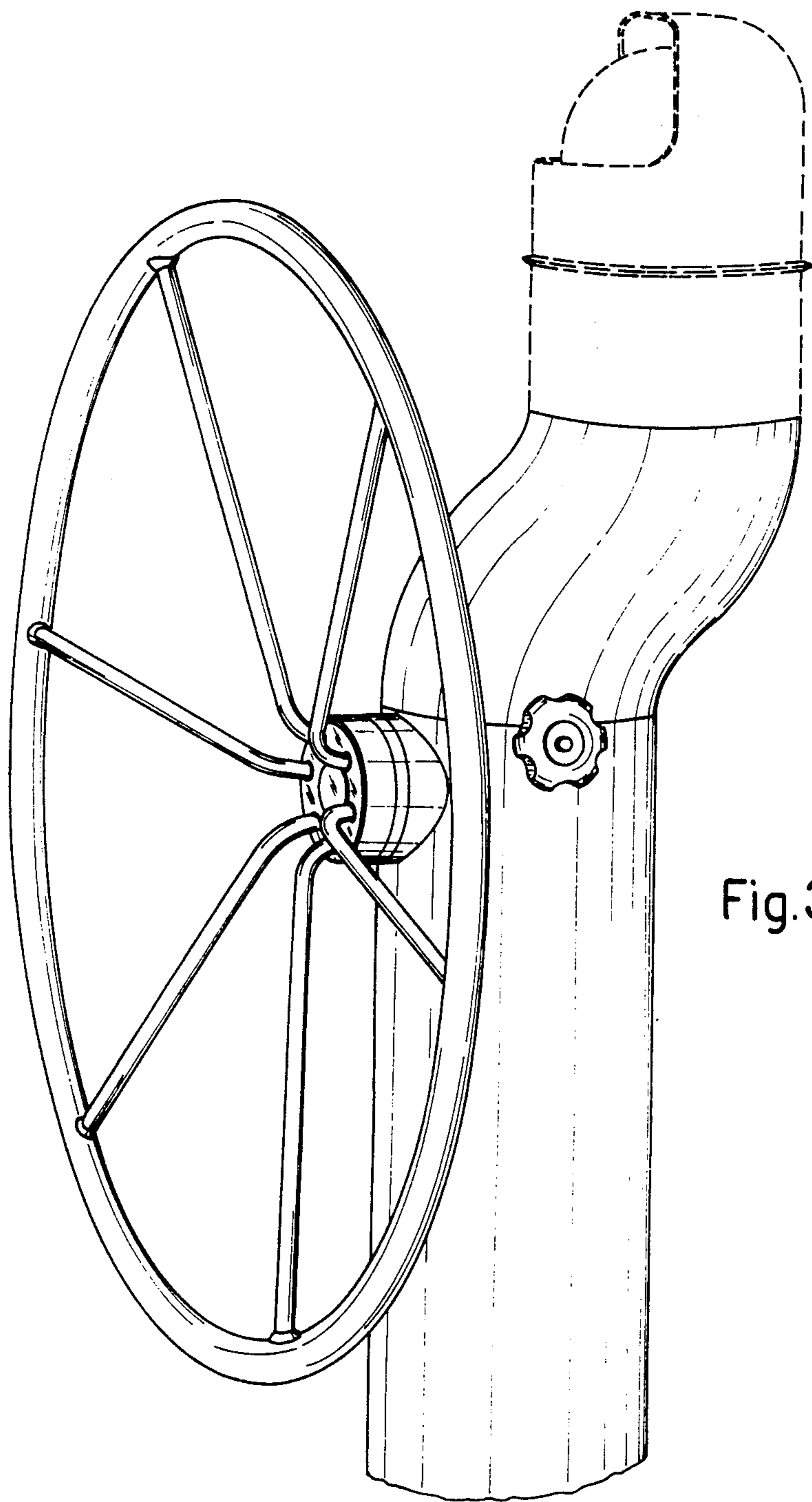

Fig. 3