

[54] CLAMP-ON GRINDING WHEEL DRESSING TOOL

[76] Inventor: William E. Fernandes, 211-A S. Whisman Rd., Mountain View, Calif. 94041

[**] Term: 14 Years

[21] Appl. No.: 891,163

[22] Filed: Mar. 28, 1978

[51] Int. Cl. D08-03

[52] U.S. Cl. D8/51; D8/52; D8/90; 125/11 R; 125/11 NT; 125/39

[58] Field of Search D8/14, 51, 52, 90; 125/11 R, 11 NT, 11 TP, 39

[56] References Cited

U.S. PATENT DOCUMENTS

- 2,367,857 1/1945 Findlater 125/39
- 2,415,121 2/1947 Wiken et al. 125/11 NT

- 2,748,761 6/1956 Winegar 125/11 NT
- 3,081,762 3/1963 Smith 125/11 NT
- 3,947,010 3/1976 Zeller D8/72

Primary Examiner—W. Stallard
Attorney, Agent, or Firm—Linval B. Castle

[57] CLAIM

The ornamental design for a clamp-on grinding wheel dressing tool, as shown.

DESCRIPTION

FIG. 1 is a perspective view illustrating the grinding wheel dressing tool of the invention;
 FIG. 2 is a top plan view illustrating the dressing tool of FIG. 1;
 FIG. 3 is a bottom view of the dressing tool;
 FIG. 4 is a side elevation view of the dressing tool;
 FIG. 5 is a front elevation view of the dressing tool illustrating the left side of the tool shown in FIG. 4; and
 FIG. 6 is an elevation view showing the right end of the tool illustrated in FIG. 4.

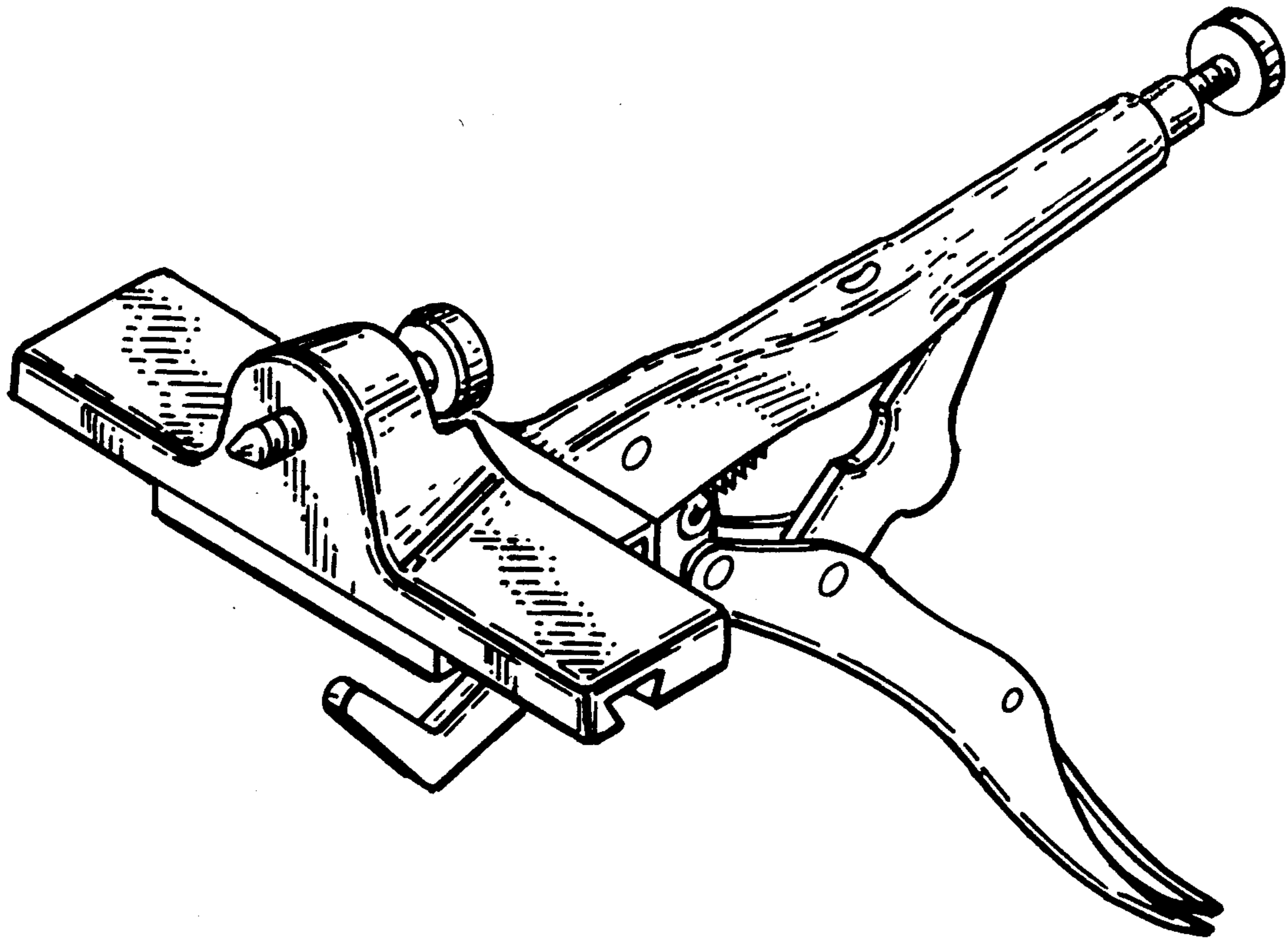

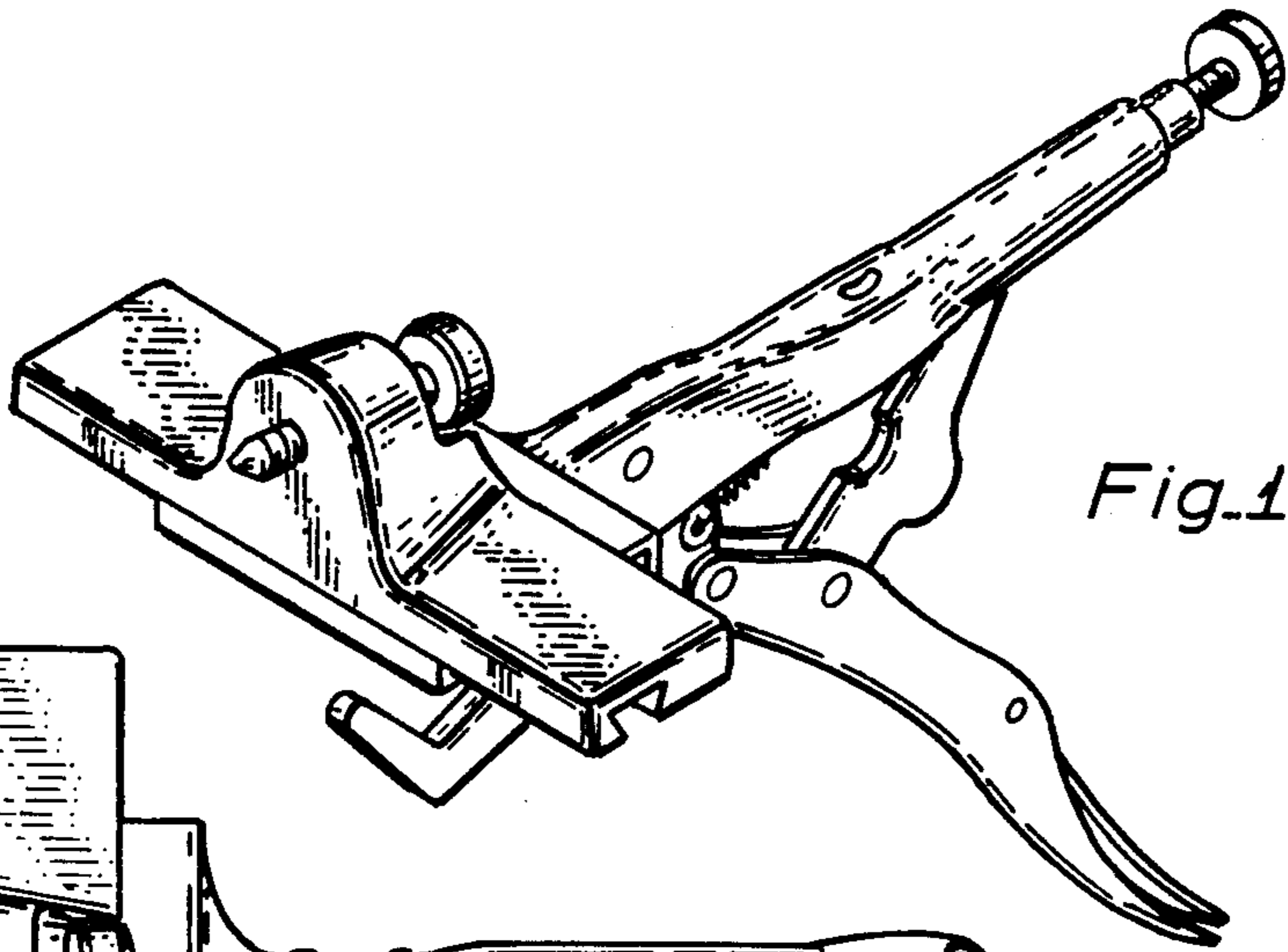

Fig. 1

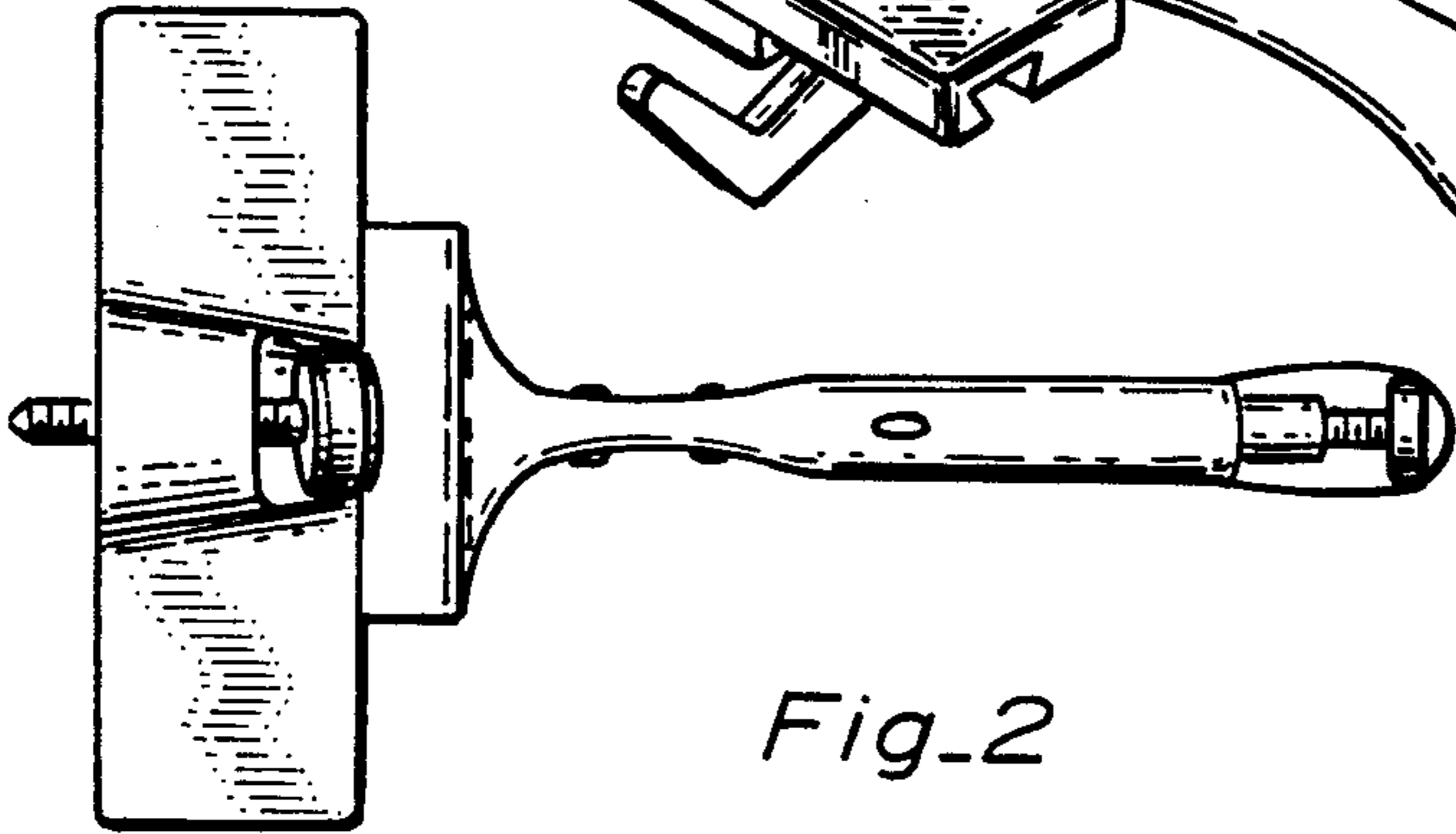

Fig. 2

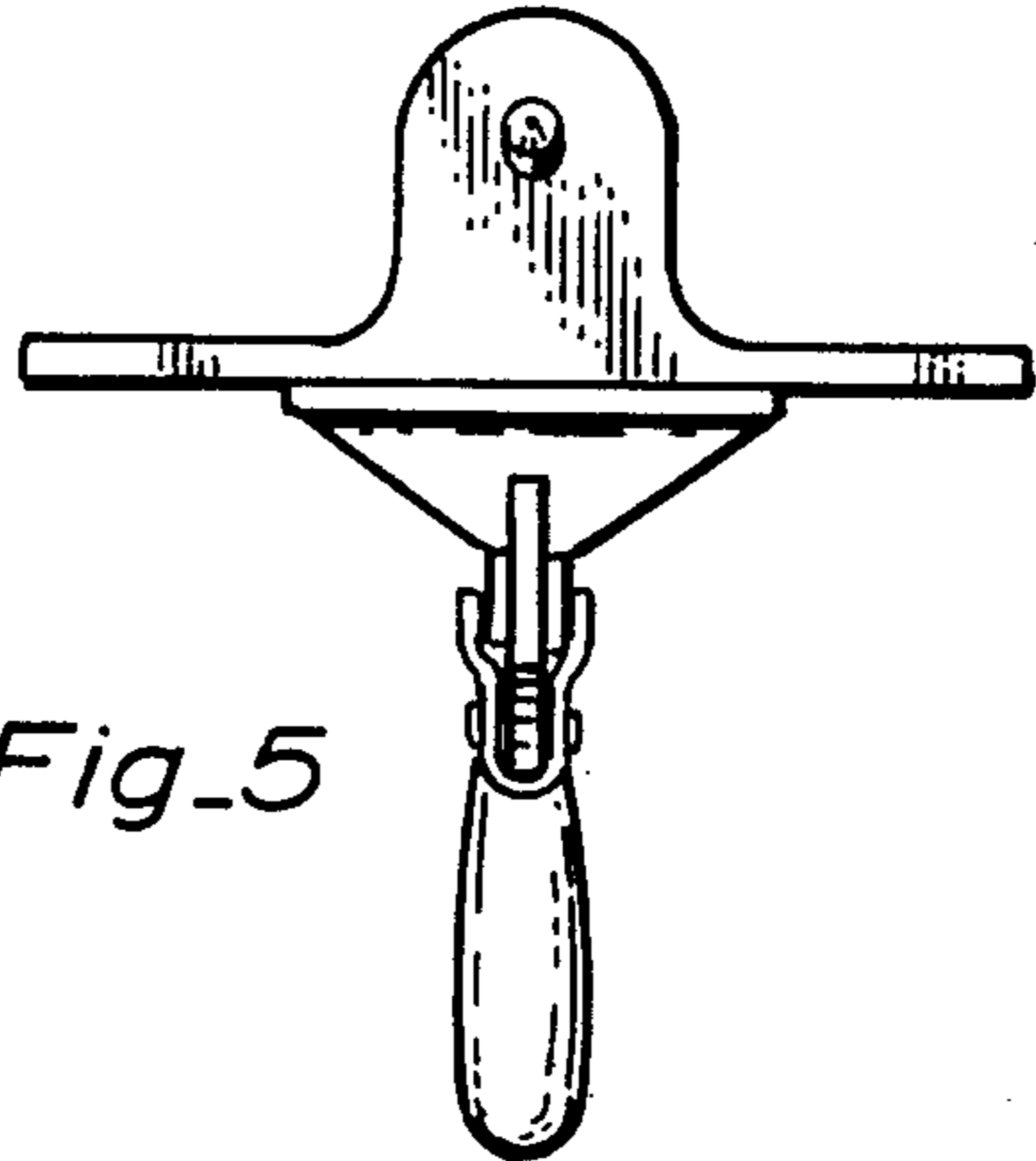

Fig. 5

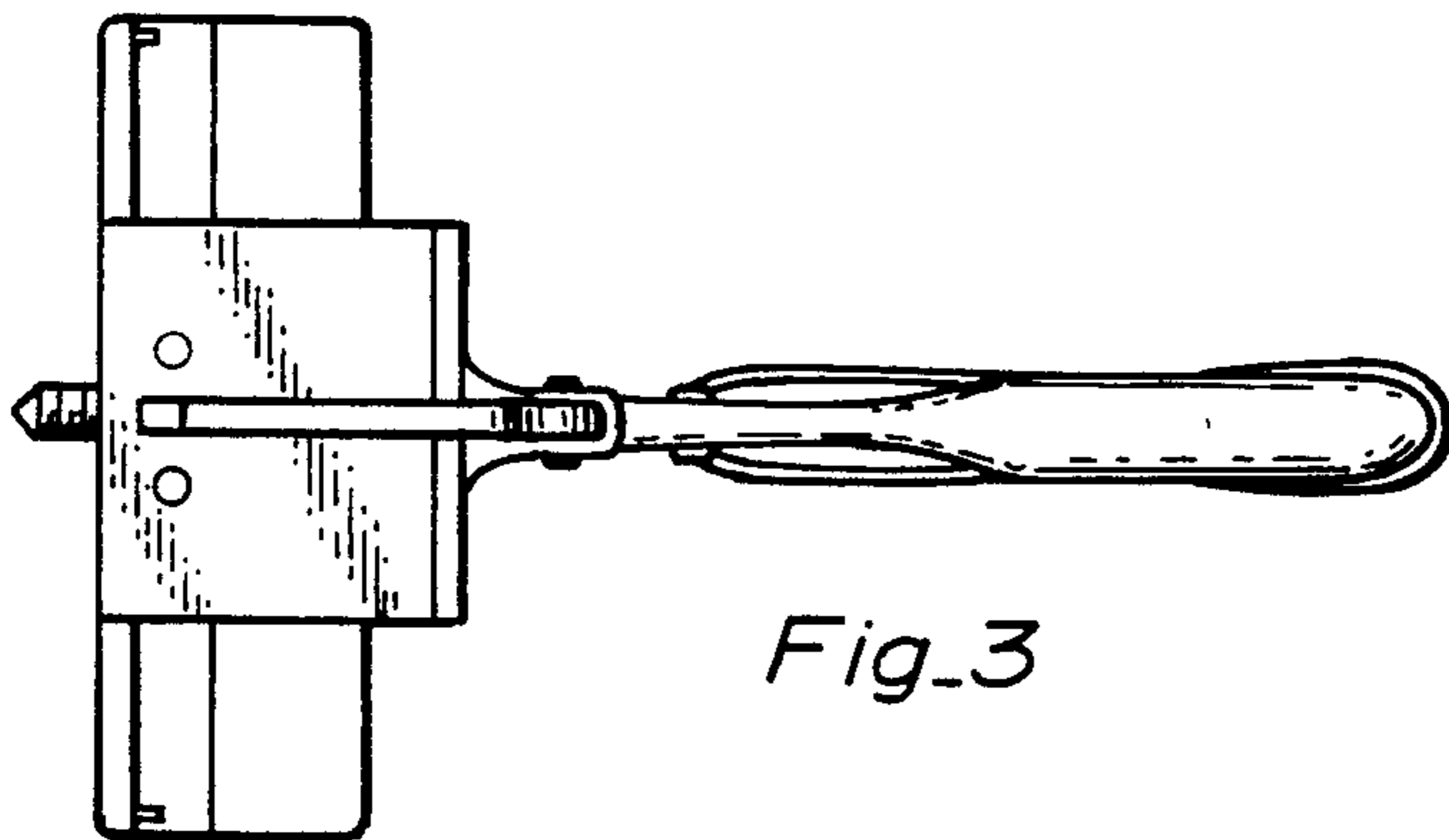

Fig. 3

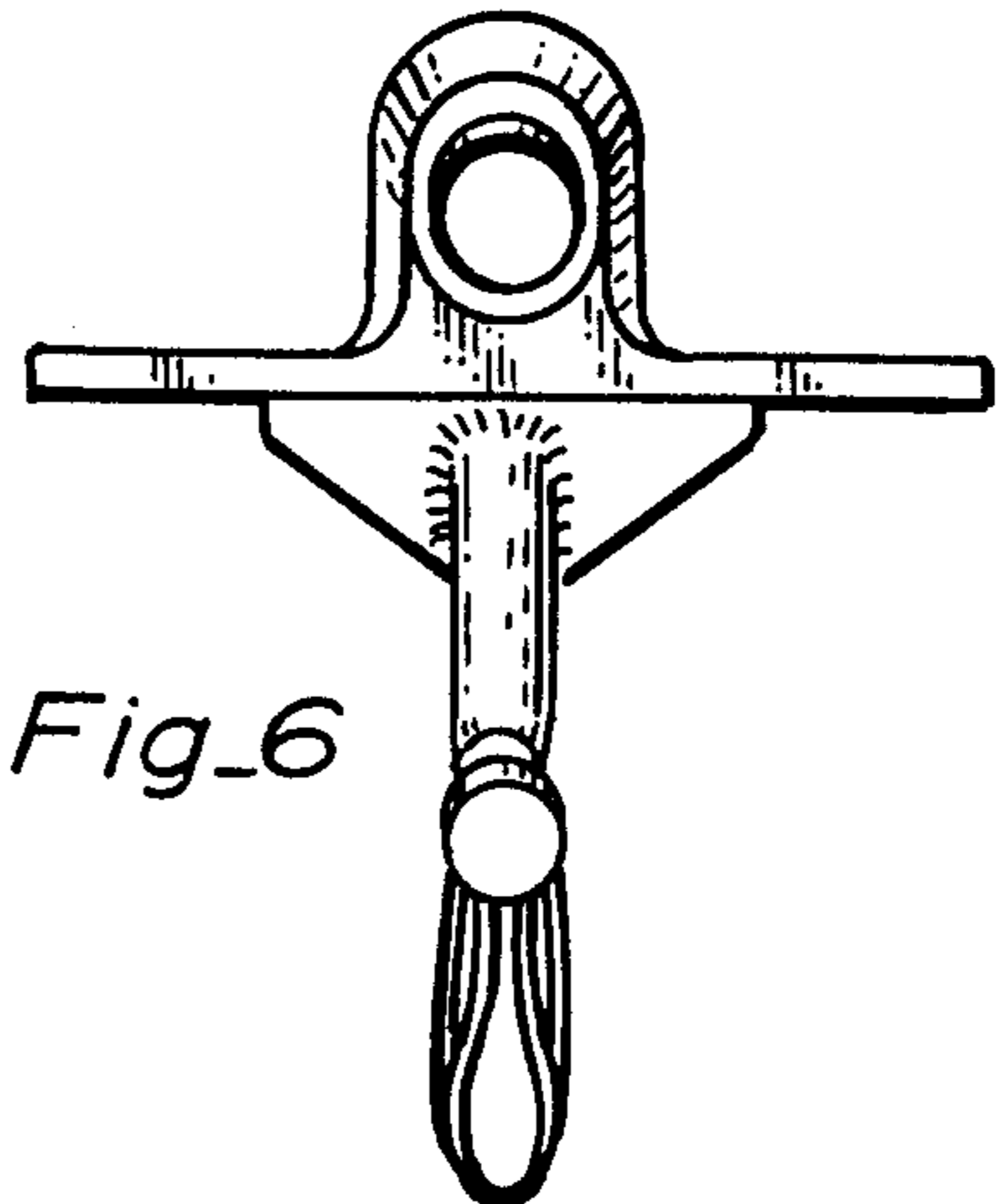

Fig. 6

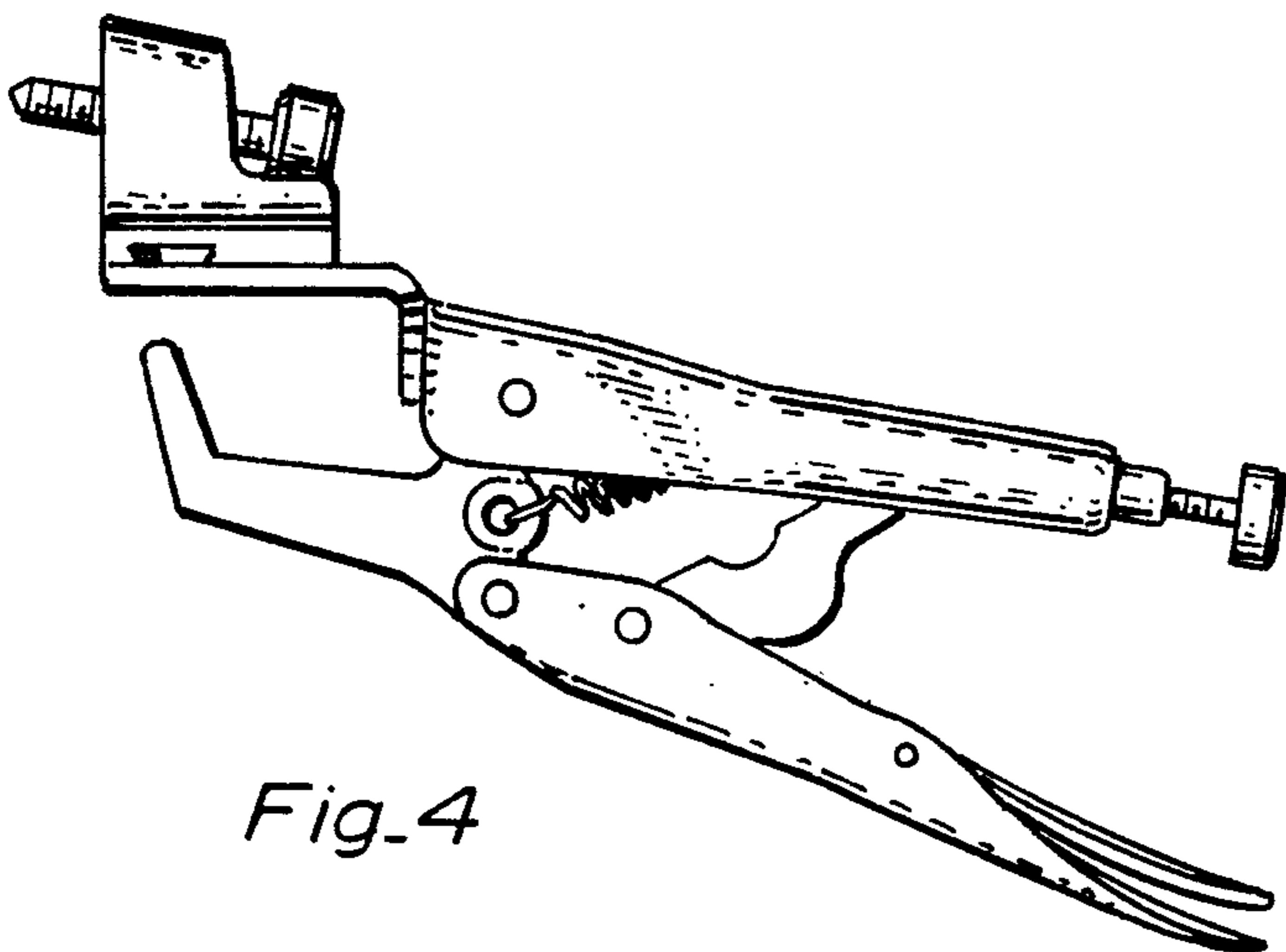

Fig. 4