

[54] RAILWAY CAR BODY

[75] Inventors: John Cuccio, Westport; Mace H. Bell, Jr., Rowayton, both of Conn.

[73] Assignee: The Budd Company, Troy, Mich.

[\*\*] Term: 14 Years

[21] Appl. No.: 866,482

[22] Filed: Jan. 3, 1978

[51] Int. Cl. .... D12-03

[52] U.S. Cl. .... D12/40

[58] Field of Search ..... D12/38, 40; 105/329 R, 105/340, 341, 342, 343, 344, 397, 401, 402

[56] References Cited

U.S. PATENT DOCUMENTS

2,589,997 3/1952 Dean et al. .... 105/340

OTHER PUBLICATIONS

Railway Age, 10/11/76, p. 22, Railway Car.

Railway Age, 10/11/76, Rear Cover, Railway Car.

Primary Examiner—James M. Gandy  
Attorney, Agent, or Firm—Alford L. Trueax, Jr.

[57] CLAIM

The ornamental design for a railway car body, substantially as shown and described.

DESCRIPTION

FIG. 1 is a front perspective view for a railway car body showing my new design;

FIG. 2 is a top plan view thereof on a reduced scale;

FIG. 3 is a side elevational view thereof on a reduced scale, the opposite side being a mirror image of the side shown;

FIG. 4 is a rear elevational view thereof on a reduced scale, and

FIG. 5 is a front perspective view of a railway car body showing a second embodiment of my new design, the top, sides and rear views thereof being substantially the same as those shown in FIGS. 2, 3 and 4, with the opposite side being a mirror image of the side shown.

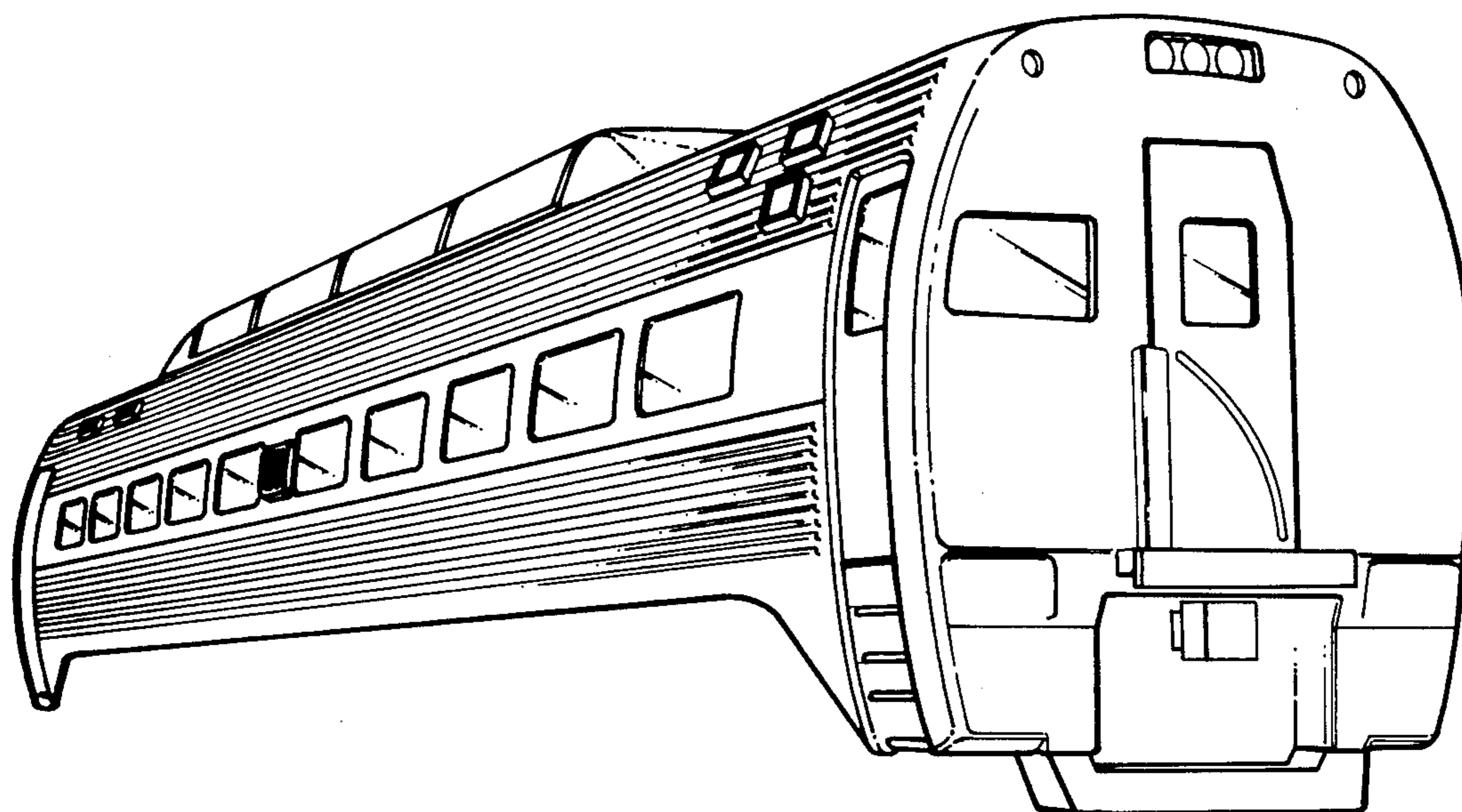

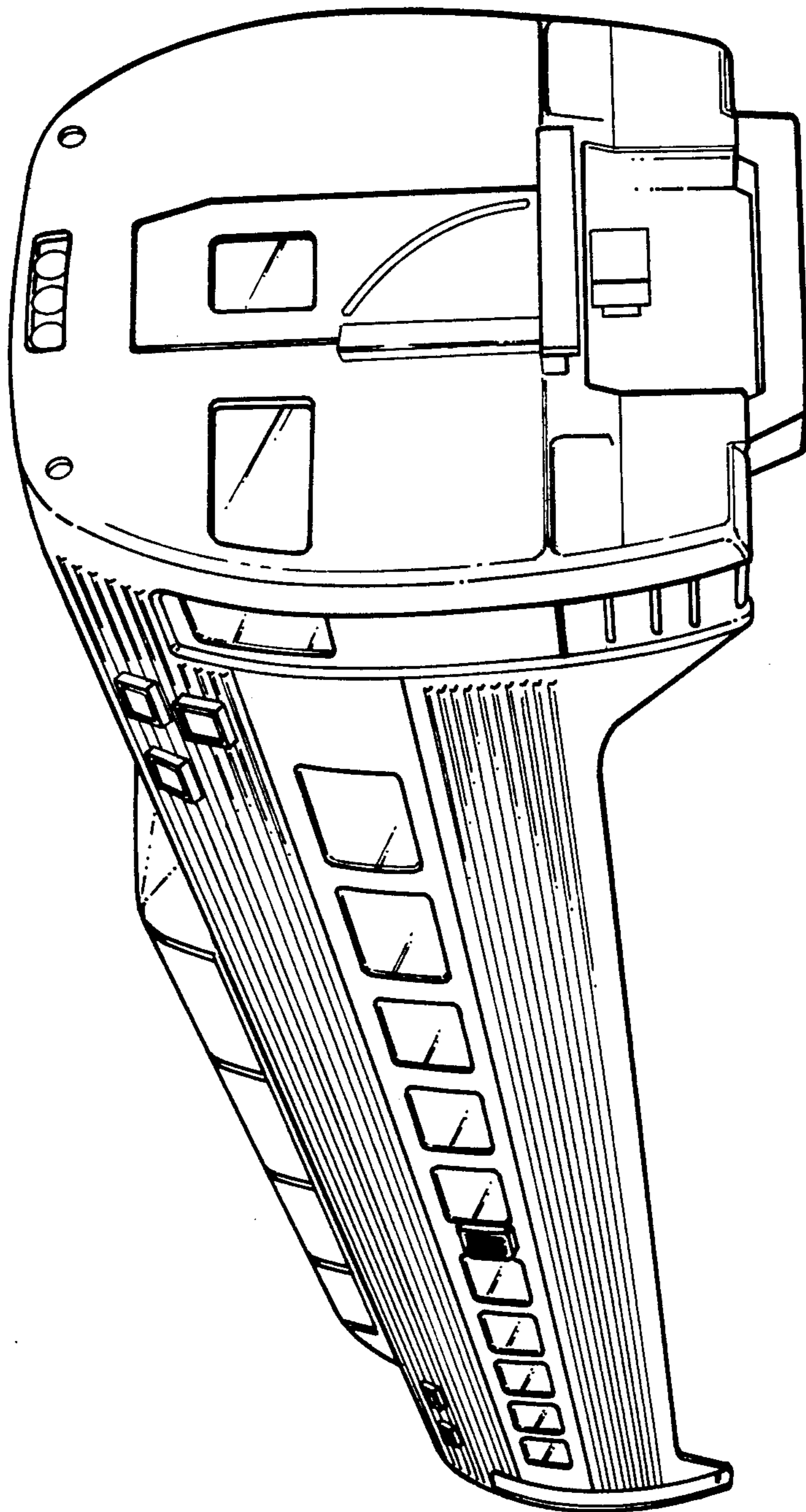

FIG. 1

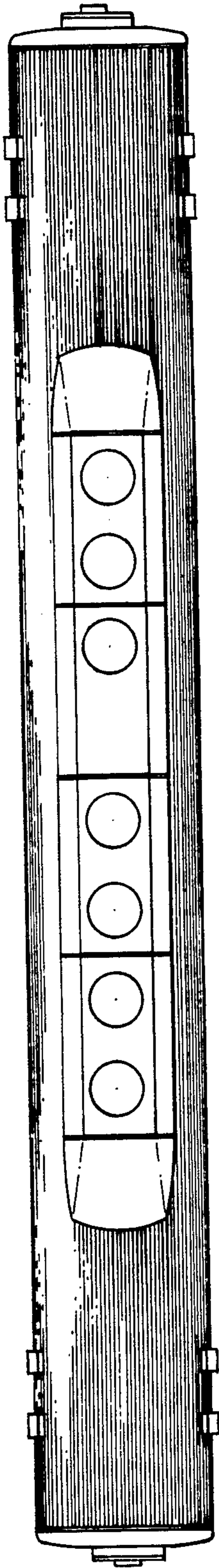

FIG. 2

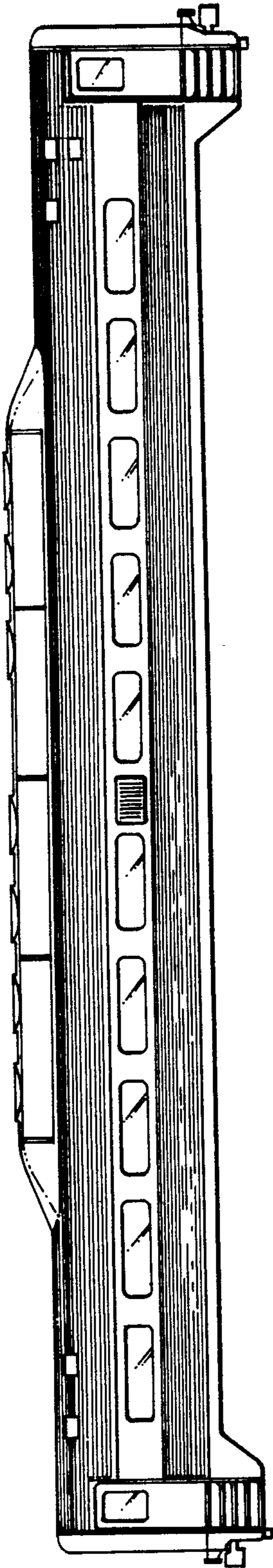

FIG. 3

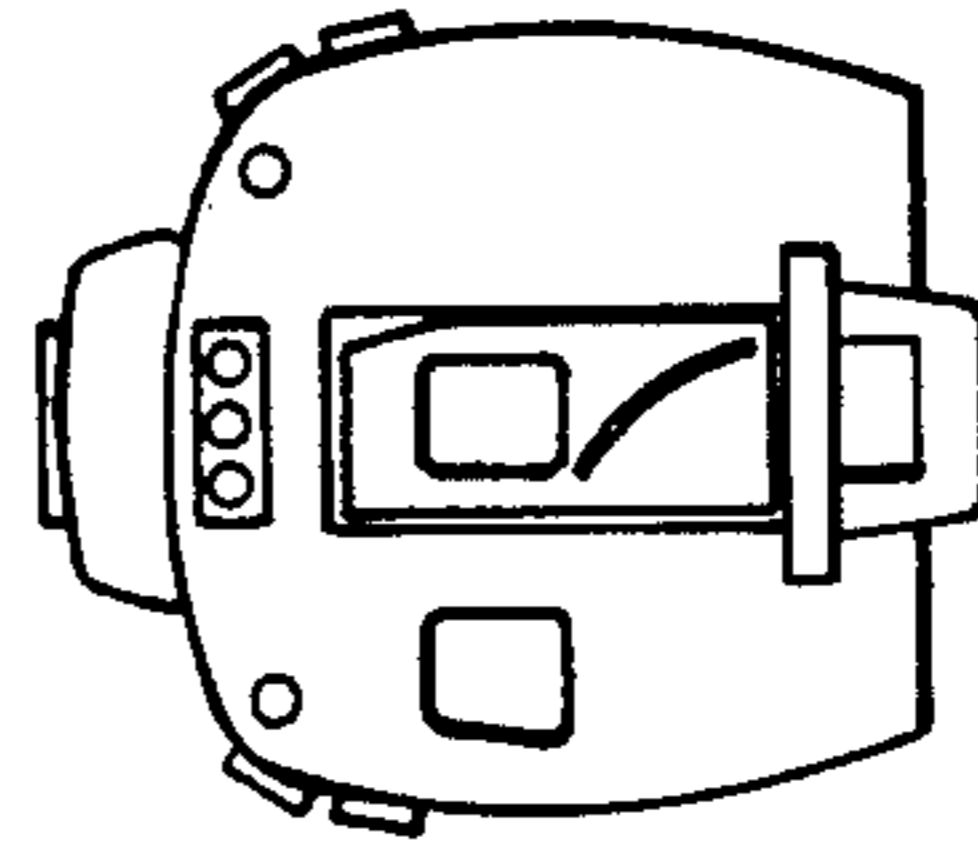

FIG. 4

FIG. 5

