

[54] CARGO RESTRAINT CLIP

[75] Inventors: George W. Armstrong, Farmingdale;
Eric G. Aronson, Livingston, both of
N.J.

[73] Assignee: Sea-Land Service, Inc., Elizabeth,
N.J.

[**] Term: 14 Years

[21] Appl. No.: 833,598

[22] Filed: Sep. 15, 1977

[51] Int. Cl. D8-08
[52] U.S. Cl. D8/382; D8/394
[58] Field of Search 248/499, 261; 52/220;
254/191; D8/354, 367, 371, 382, 394, 395

[56]

References Cited

U.S. PATENT DOCUMENTS

D. 173,146 10/1954 Davis, Jr. D8/395
3,288,544 11/1966 Knecht 248/261 X

OTHER PUBLICATIONS

Grammes Metal Products Catalog #66, c. 1941, p. 32,
Pipe Hook, No. 31425.

Primary Examiner—A. Hugo Word
Attorney, Agent, or Firm—David Rabin

[57]

CLAIM

The ornamental design for a cargo restraint clip, as
shown.

DESCRIPTION

FIG. 1 is a perspective view of a cargo restraint clip
embodying our invention;
FIG. 2 is an end elevational view of FIG. 1 somewhat
reduced in size;
FIG. 3 is a top plan view of FIG. 2; and
FIG. 4 is a left end view of FIG. 2.

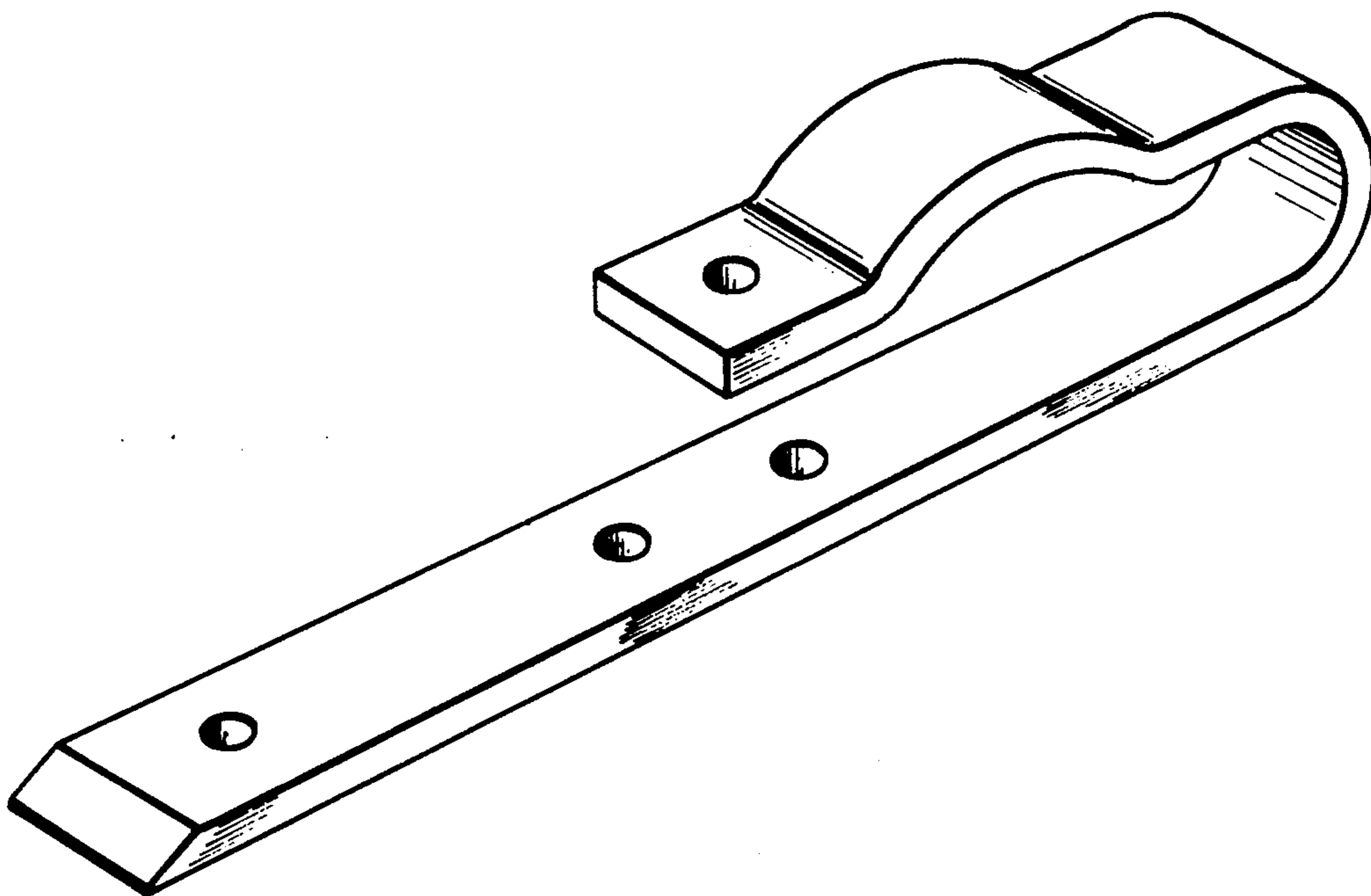

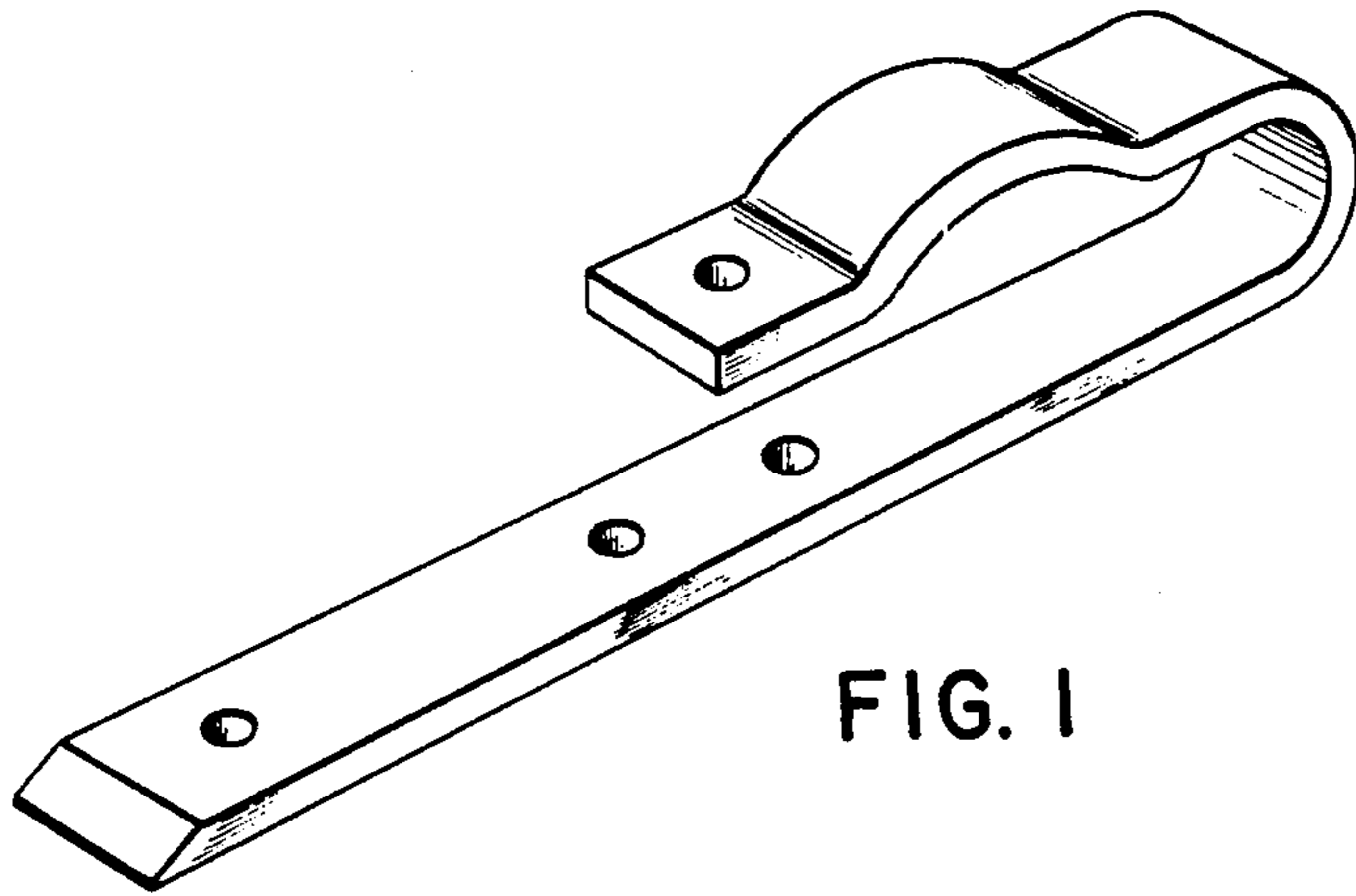

FIG. 1

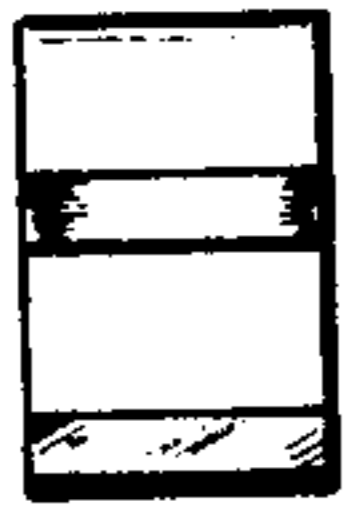

FIG. 4

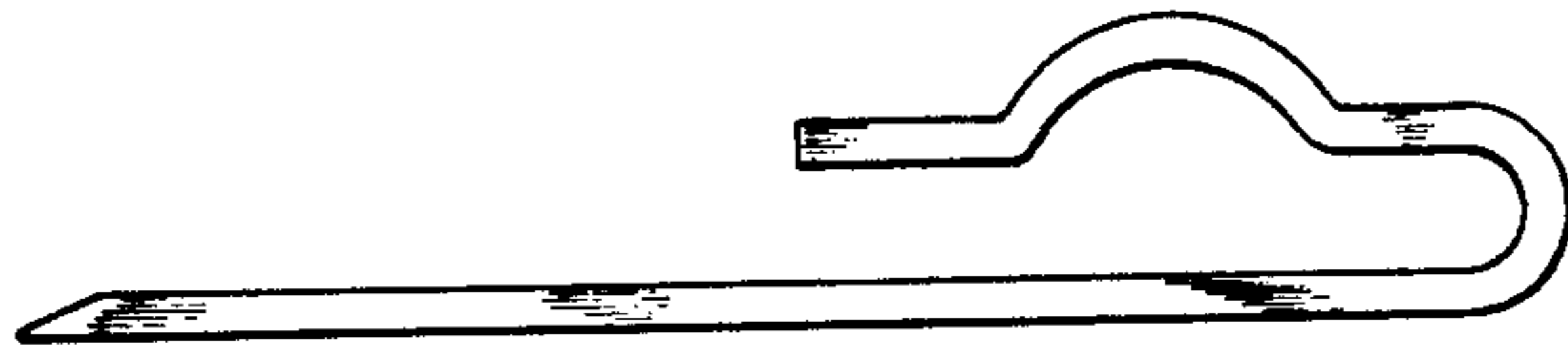

FIG. 2



FIG. 3