

[54] LANTERN

[75] Inventors: Chung-Chee Wong, Kowloon, Hong Kong; David R. Dalton, Sydney, Australia

[73] Assignees: Sonca Industries Limited, Kowloon, Hong Kong; Union Carbide Australia Limited, Sydney, Australia

[**] Term: 14 Years

[21] Appl. No.: 906,280

[22] Filed: May 15, 1978

[30] Foreign Application Priority Data
Dec. 13, 1977 [GB] United Kingdom 982597/77

[51] Int. Cl. D26-02
[52] U.S. Cl. D26/48

[58] Field of Search D48/24 R, 24 A; 362/157, 183, 189, 190, 194, 195, 196, 197, 198, 199, 200, 201, 202, 203, 204, 205

[56] References Cited
U.S. PATENT DOCUMENTS
D. 226,219 1/1973 Brindley D48/24 R
3,539,797 11/1970 Brindley et al. D48/24 R X

Primary Examiner—Susan J. Lucas
Attorney, Agent, or Firm—Wenderoth, Lind & Ponack

[57] CLAIM
The ornamental design for lantern, substantially as shown.

DESCRIPTION

FIG. 1 is a side view of the lantern showing our new design,
FIG. 2 is a top plan view of the lantern,
FIG. 3 is a front view of the lantern,
FIG. 4 is a rear view of the lantern, and
FIG. 5 is a front perspective view of the lantern.

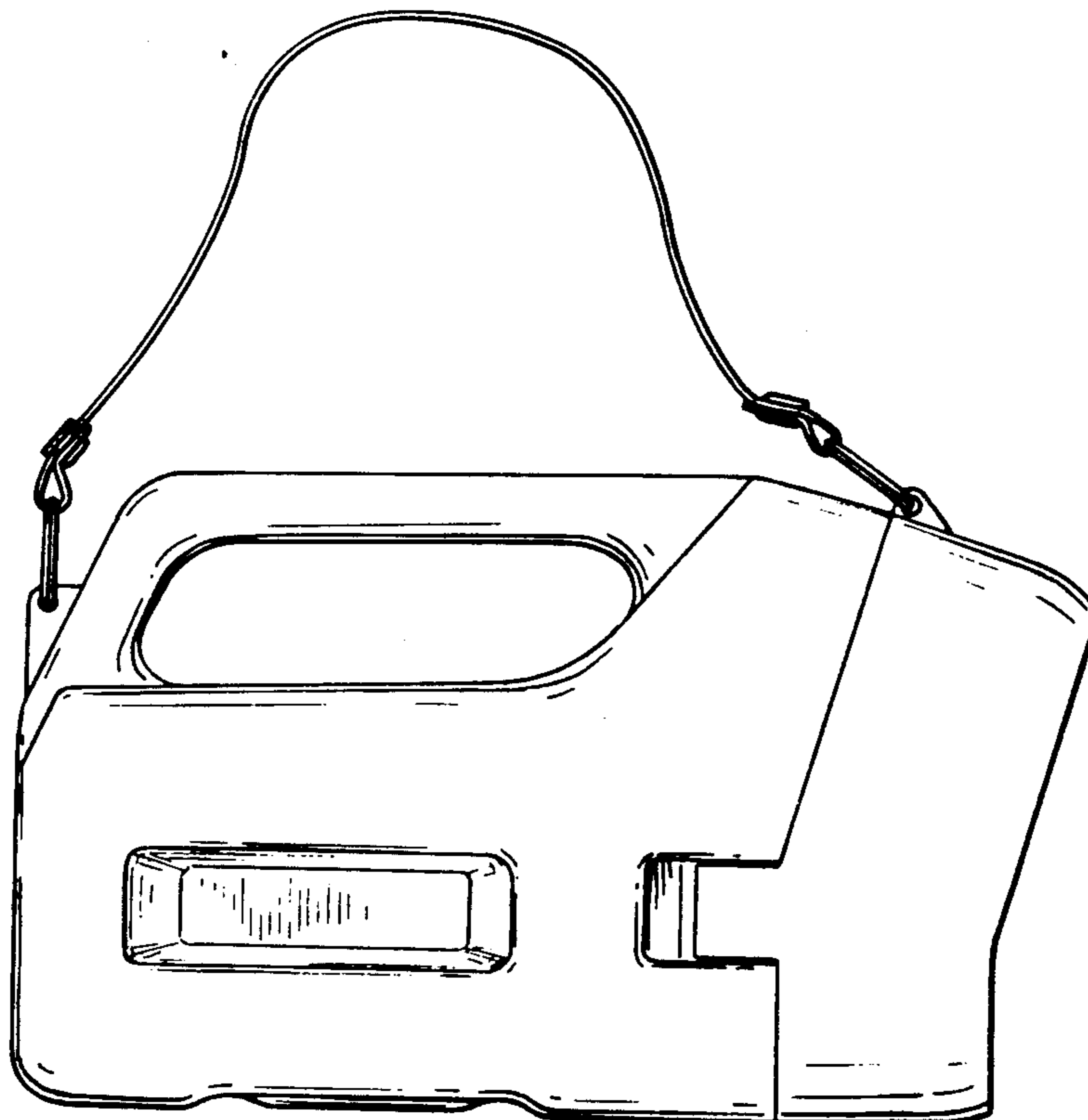

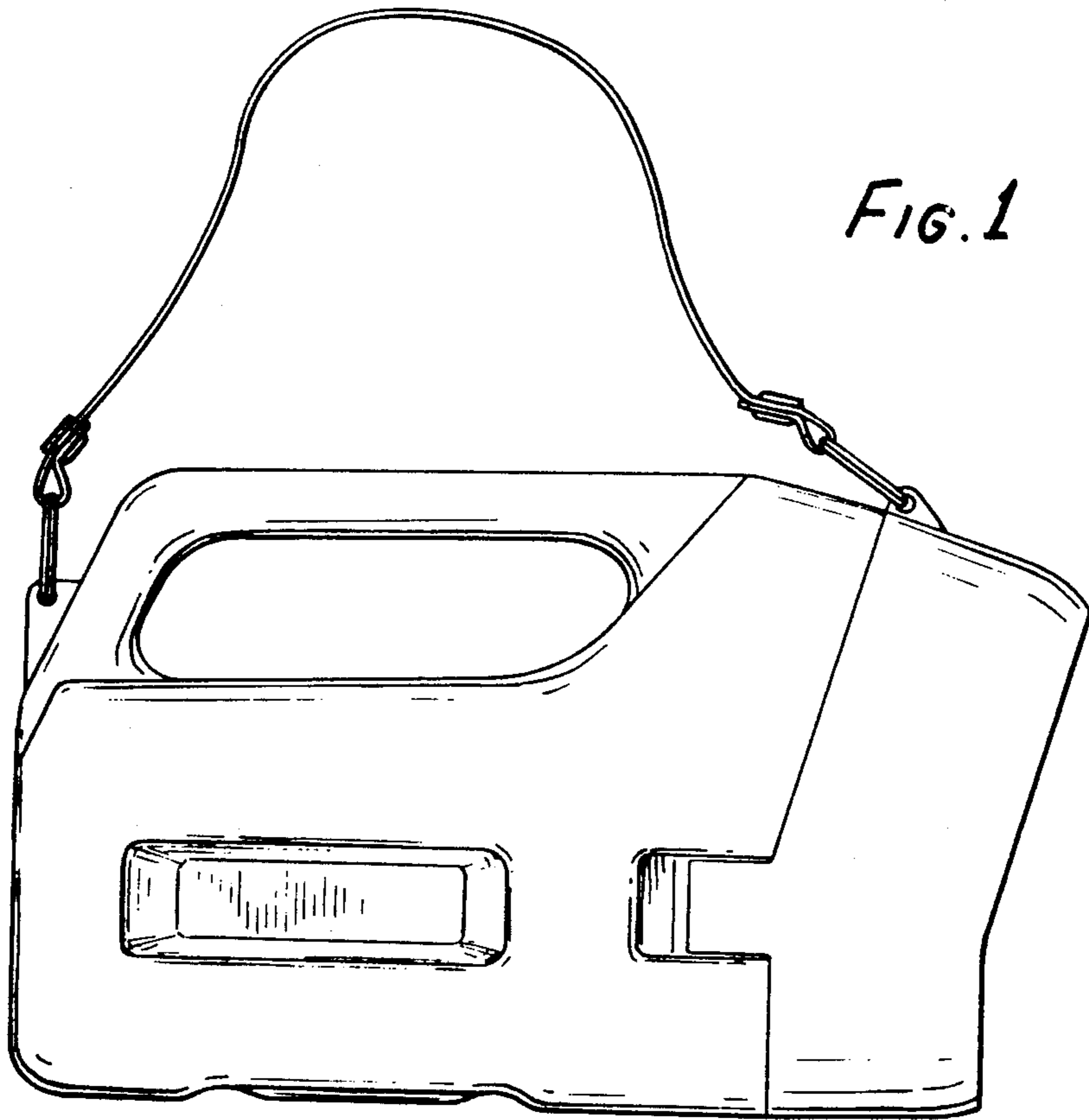

FIG. 1

FIG. 2

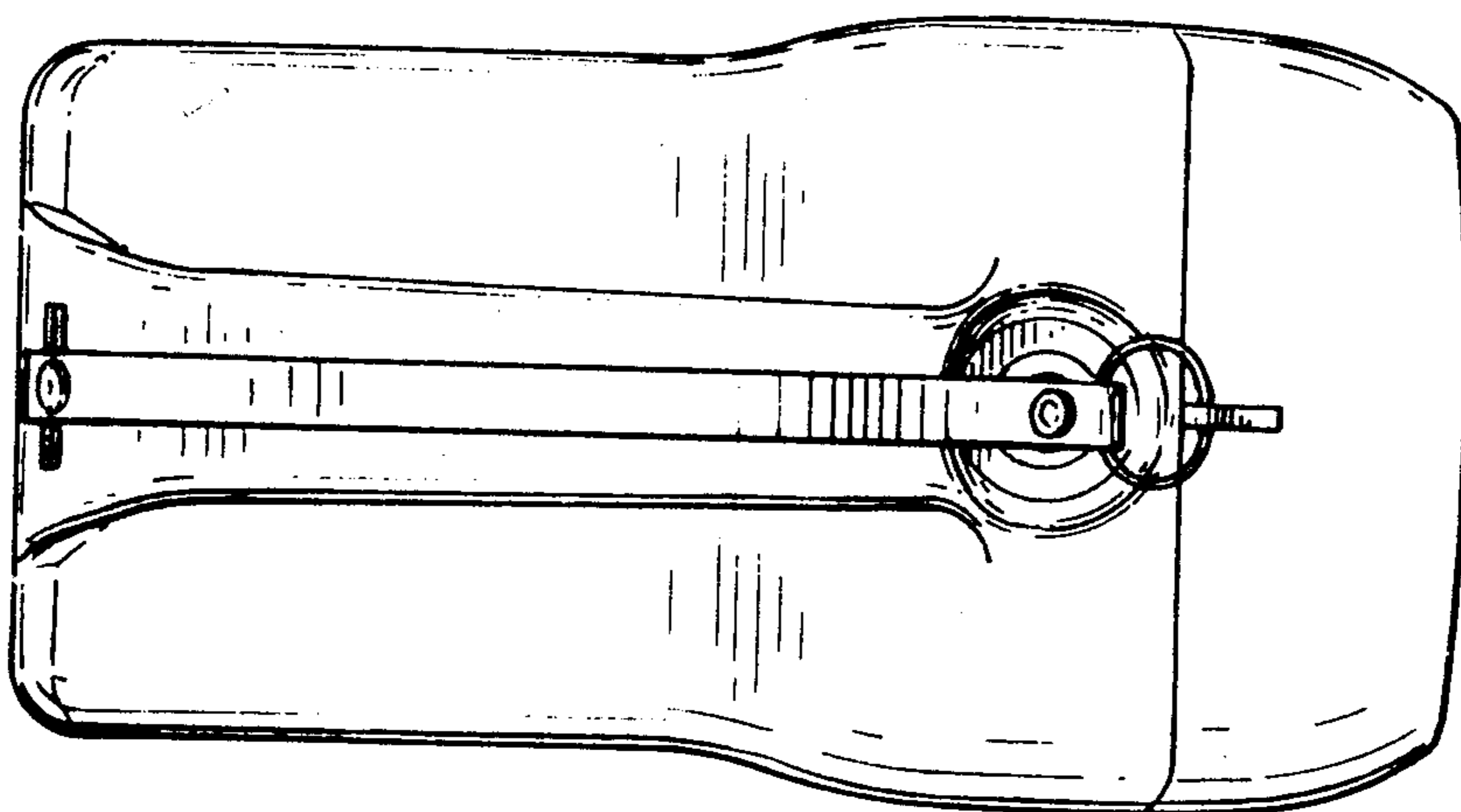

FIG. 3

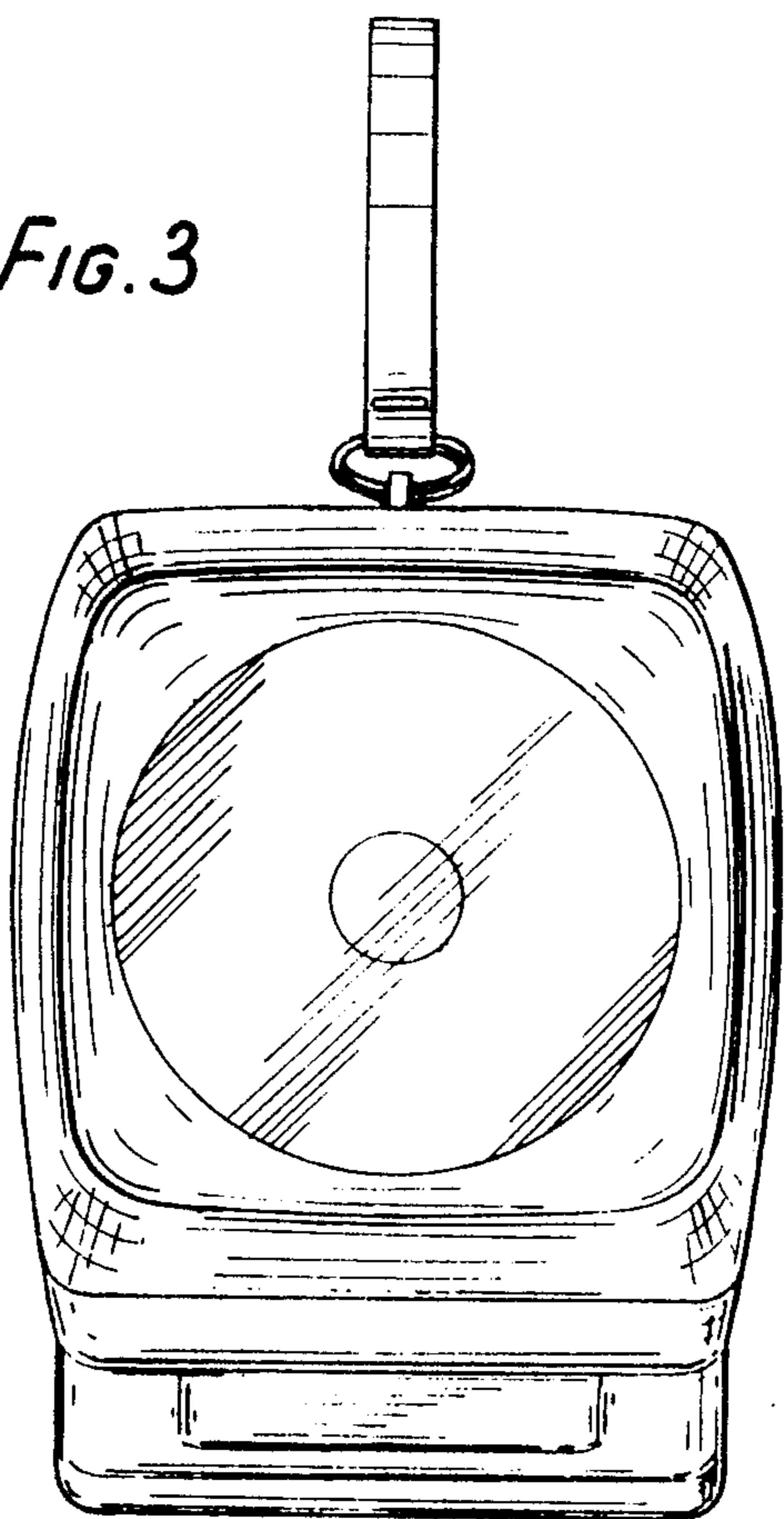

FIG. 4

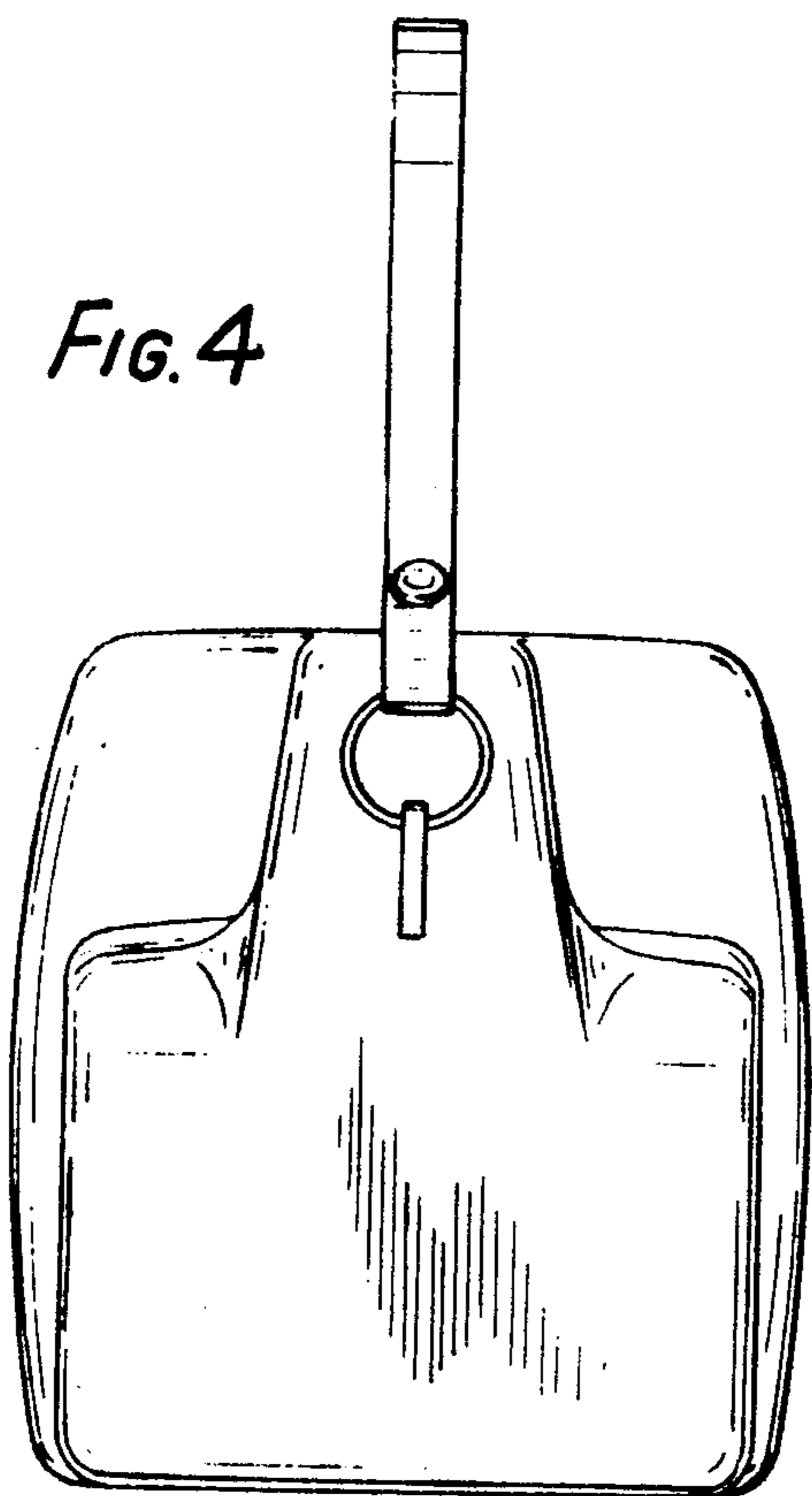

FIG. 5

