

[54] LUG NUT LOCK FOR AN AUTOMOBILE WHEEL

[76] Inventor: Frank E. Baylis, 221 Richmond Ave., West Haven, Conn. 06516

[**] Term: 14 Years

[21] Appl. No.: 803,373

[22] Filed: Jun. 1, 1977

[51] Int. Cl. D8-07

[52] U.S. Cl. D8/331

[58] Field of Search D8/331, 334; 70/225-228, 229-232, 259

[56] References Cited

U.S. PATENT DOCUMENTS

D. 133,034	7/1942	George	D8/331
2,099,606	11/1937	Holsen	70/227
3,540,245	11/1970	Pope	70/231

Primary Examiner—James M. Gandy

[57] CLAIM

The ornamental design for a lug nut lock for an automobile wheel, as shown.

DESCRIPTION

FIG. 1 is a perspective view of a lug nut lock for an automobile wheel showing my new design; FIG. 2 is a side elevational view thereof opposite to that shown in FIG. 1; FIG. 3 is a cross sectional view thereof taken along the line 3-3 in FIG. 2.

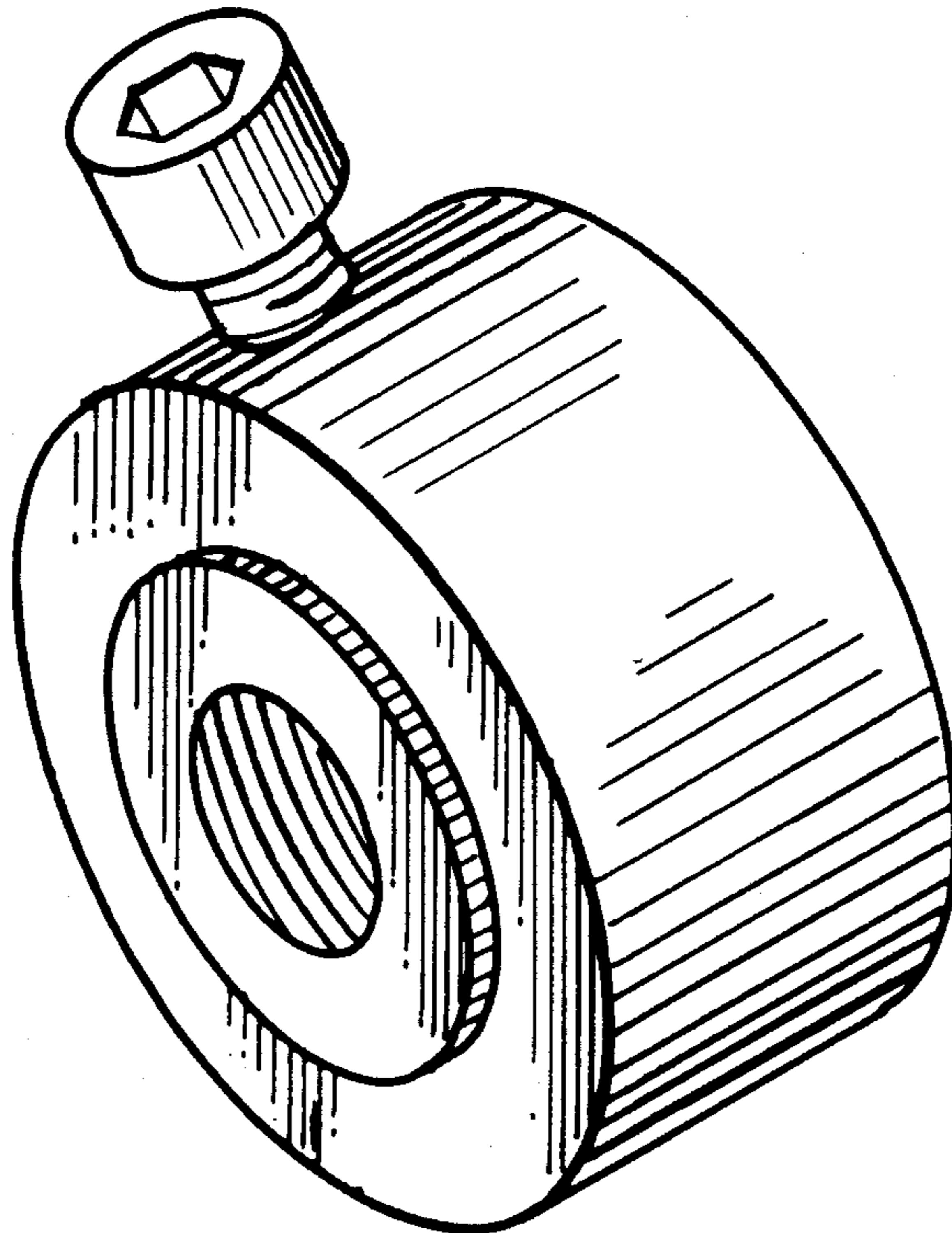

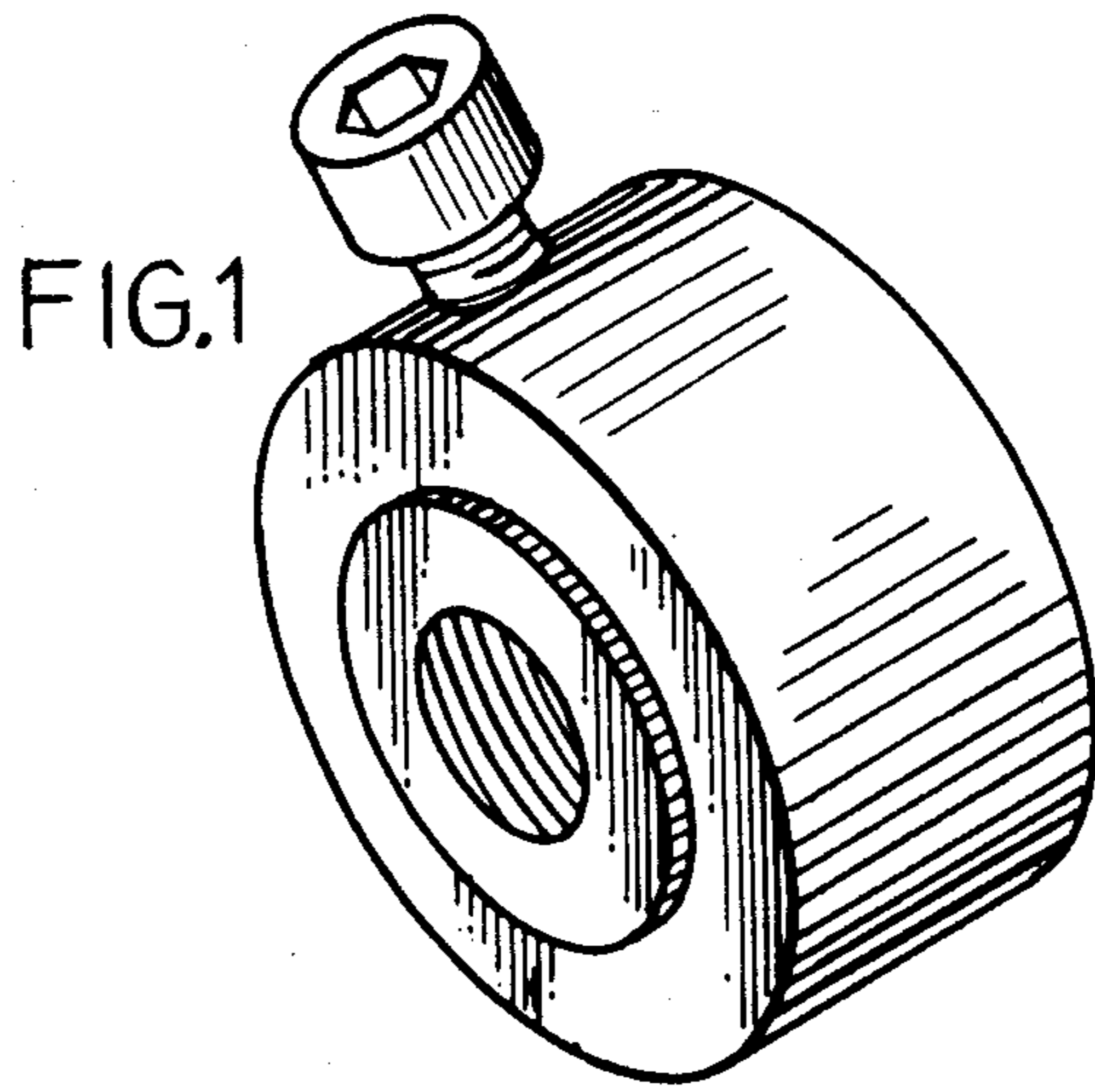

FIG.3

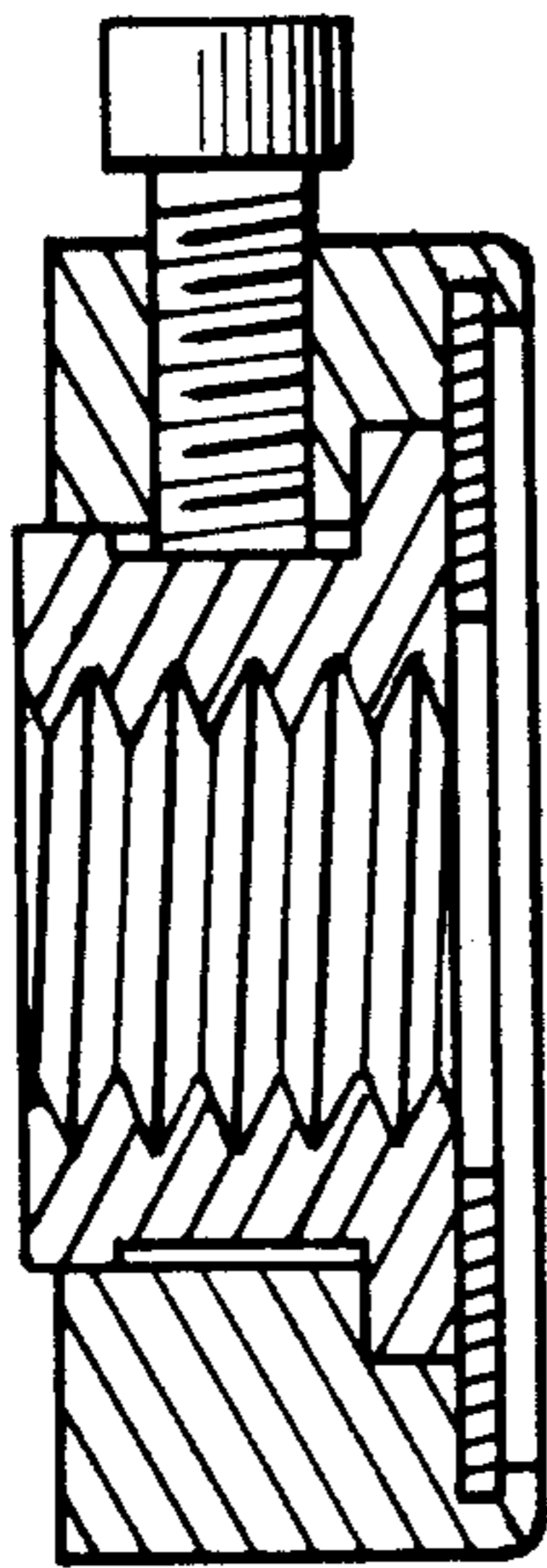

FIG.2

