

[54] HOUSING FOR VIBRATION-ABRASIVE SURFACE FINISHING MACHINES

[75] Inventors: Carl K. Walther, Wuppertal; Henning D. Walther, Haan; Hubert P. Hagelüken, Düsseldorf; Karl Teme, Wuppertal, all of Fed. Rep. of Germany

[73] Assignee: Carl Kurt Walther GmbH & Co. KG, Wuppertal, Fed. Rep. of Germany

[**] Term: 14 Years

[21] Appl. No.: 843,897

[22] Filed: Oct. 20, 1977

[30] Foreign Application Priority Data

Apr. 21, 1977 [DE] Fed. Rep. of Germany 5413982

[51] Int. Cl. D15-04; D15-09

[52] U.S. Cl. D15/124; D15/147

[58] Field of Search D15/147, 124; 51/163.1, 51/163.2, 7; 366/183

[56] References Cited

U.S. PATENT DOCUMENTS

D. 236,155	7/1975	Lower et al.	D15/147
3,693,298	9/1972	Ferrara	51/163.2
4,118,896	10/1978	Walther et al.	51/163.2
4,161,848	7/1979	Jones	51/163.2

Primary Examiner—W. Stallard
Attorney, Agent, or Firm—Martin A. Farber

[57] CLAIM

The ornamental design for a housing for vibration-abrasive surface finishing machines, as shown and described.

DESCRIPTION

FIG. 1 is a perspective view of a housing for vibration-abrasive surface finishing machines showing our design; FIG. 2 is a right side view of the housing of FIG. 1 with the base partly broken away; FIG. 3 is a left side view of the housing of FIG. 1 with the base partly broken away; FIG. 4 is a top plan view of the housing of FIG. 1; FIG. 5 is a front elevational view of the housing of FIG. 1 with the base partly broken away; FIG. 6 is a rear elevational view of the housing of FIG. 1 with the base partly broken away; FIG. 7 is a right side view of another embodiment of an arena-shaped vibration-abrasive container for surface finishing machines showing our design; FIG. 8 is a left side view of the housing of FIG. 7; FIG. 9 is a top plan view of the housing of FIG. 7; FIG. 10 is a front elevational view of the housing of FIG. 7 with the base partly broken away; and FIG. 11 is a rear elevational view of the housing of FIG. 7 with the base partly broken away. FIGS. 1, 4 and 9 show an abrasive material in broken lines for illustrative purposes only.

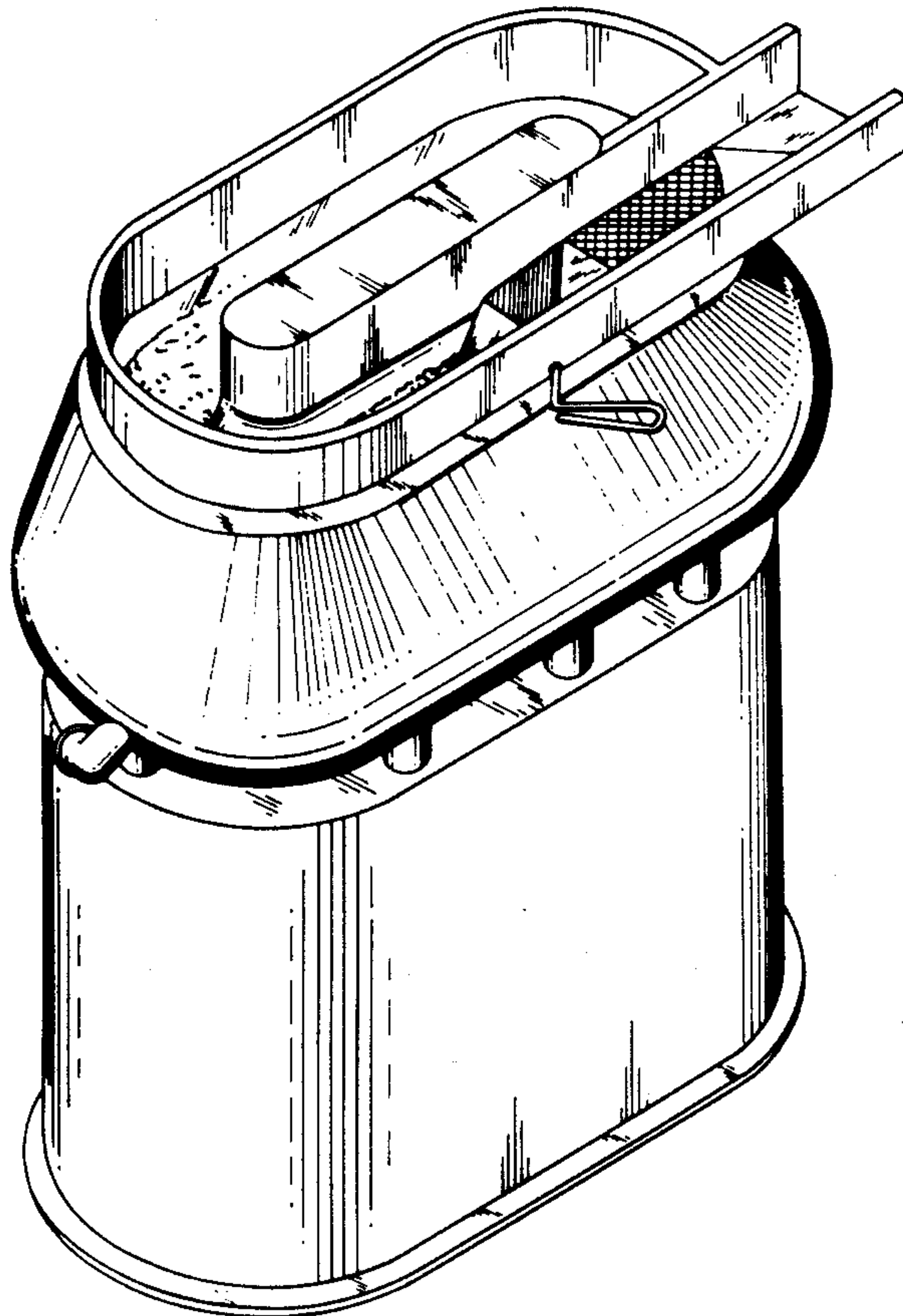
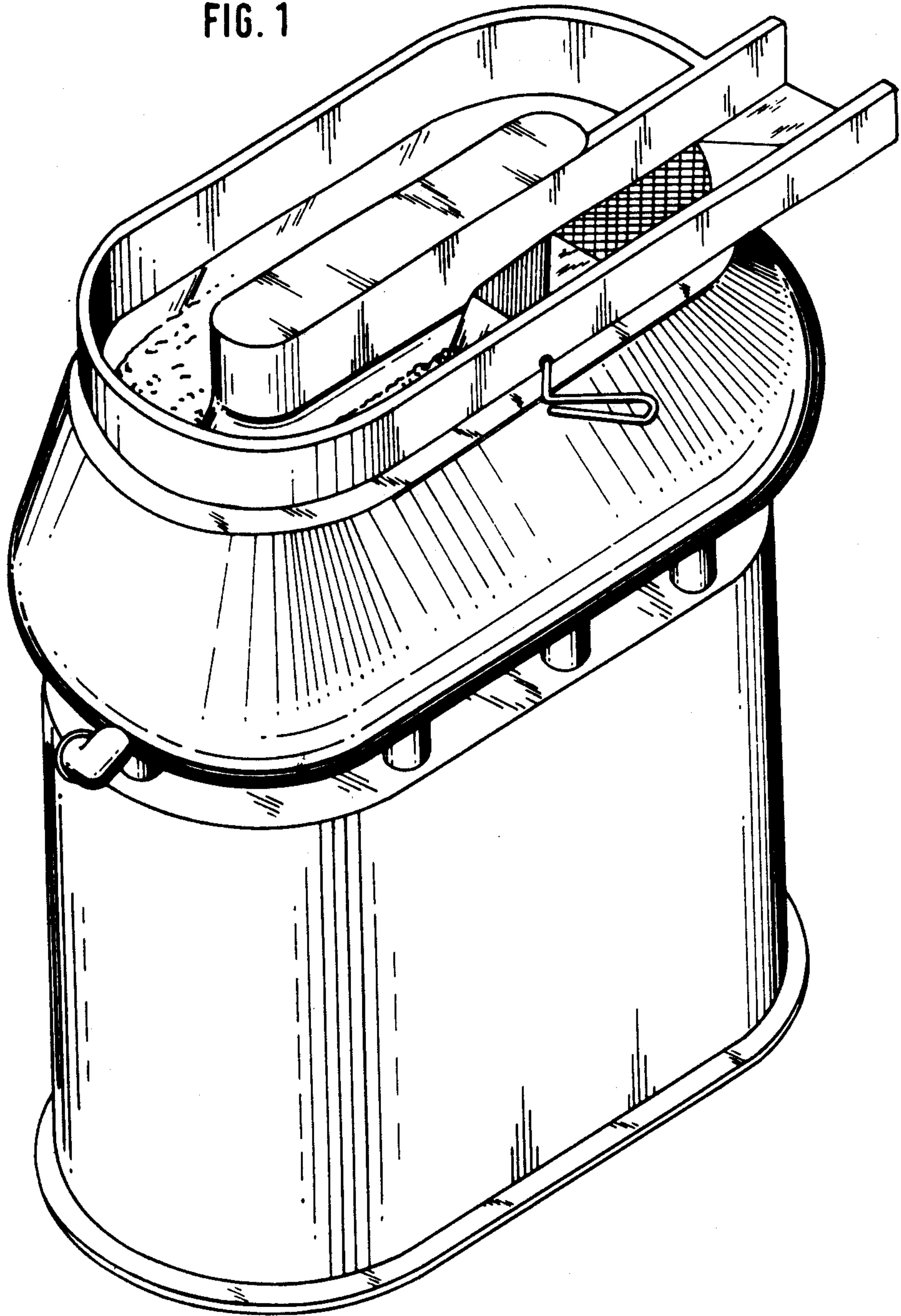

FIG. 1



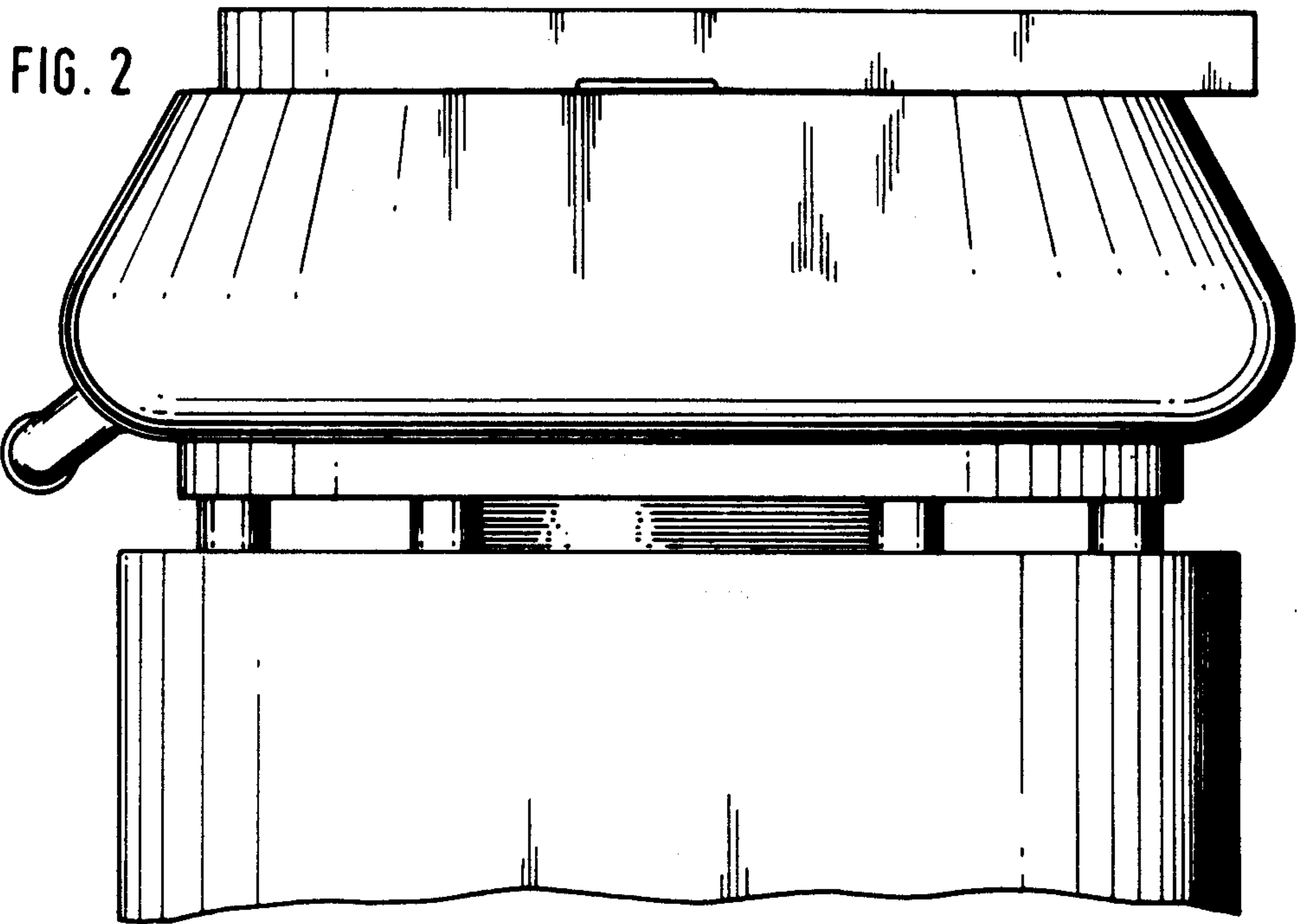

FIG. 4

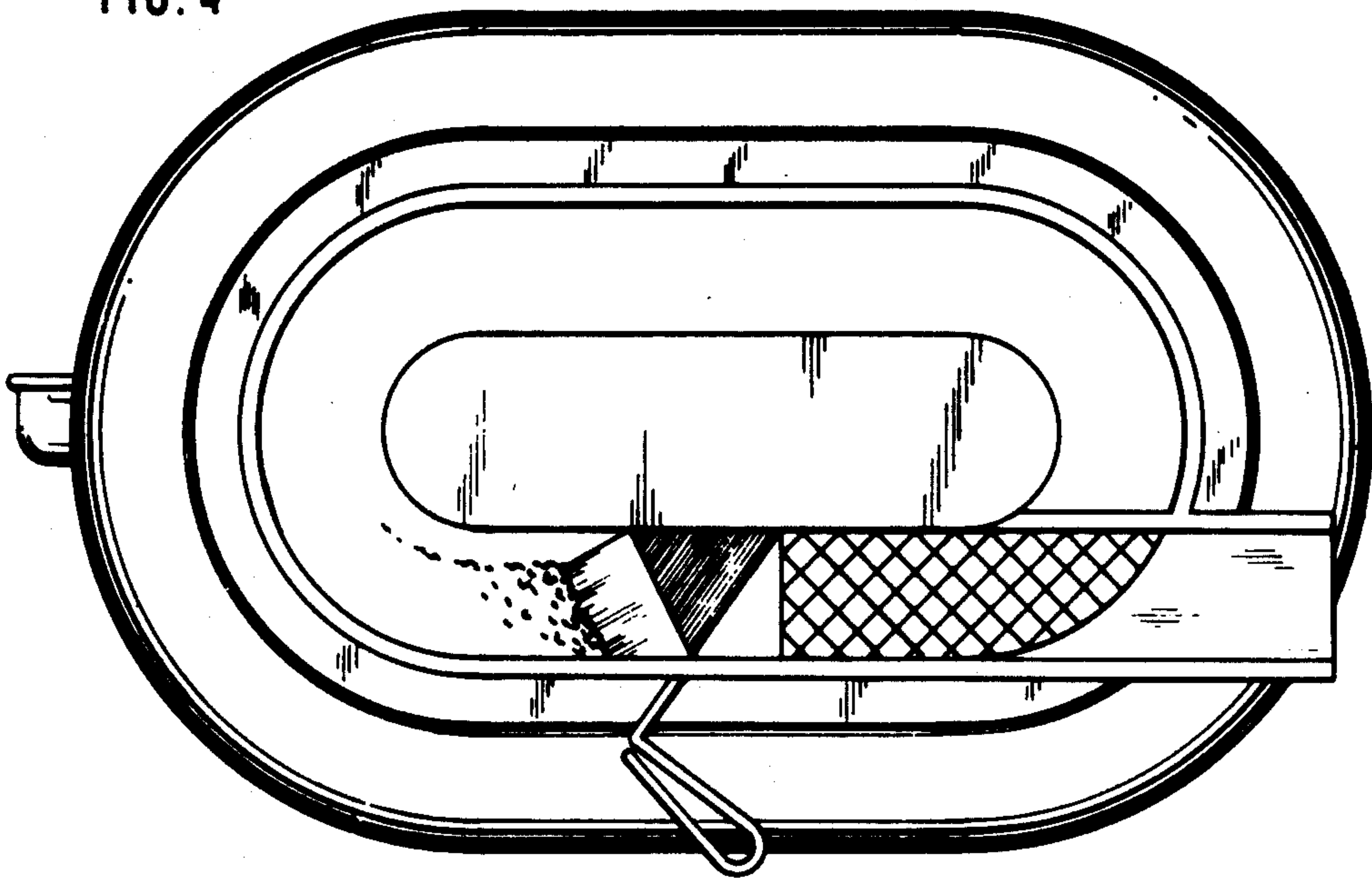
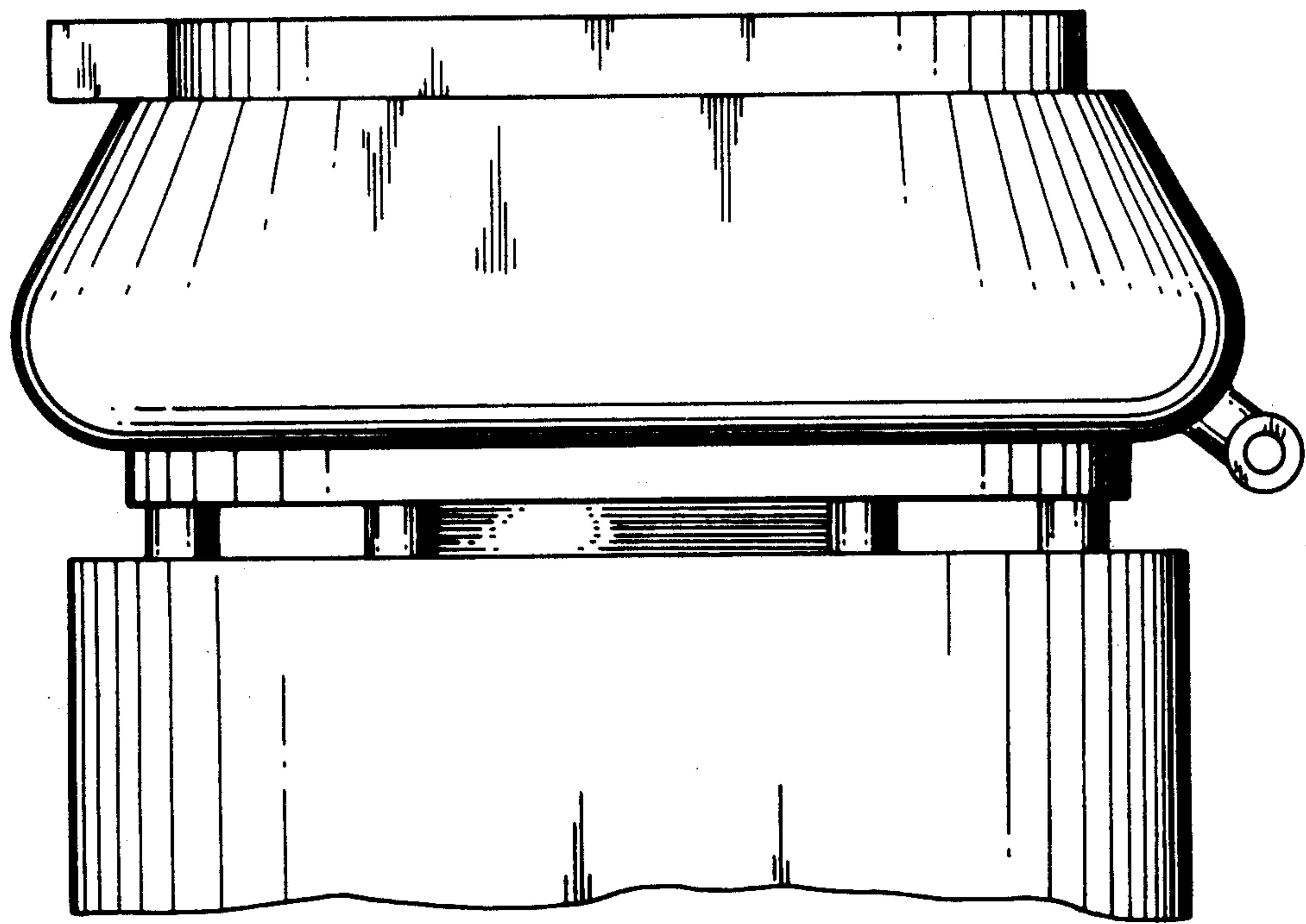

FIG. 3



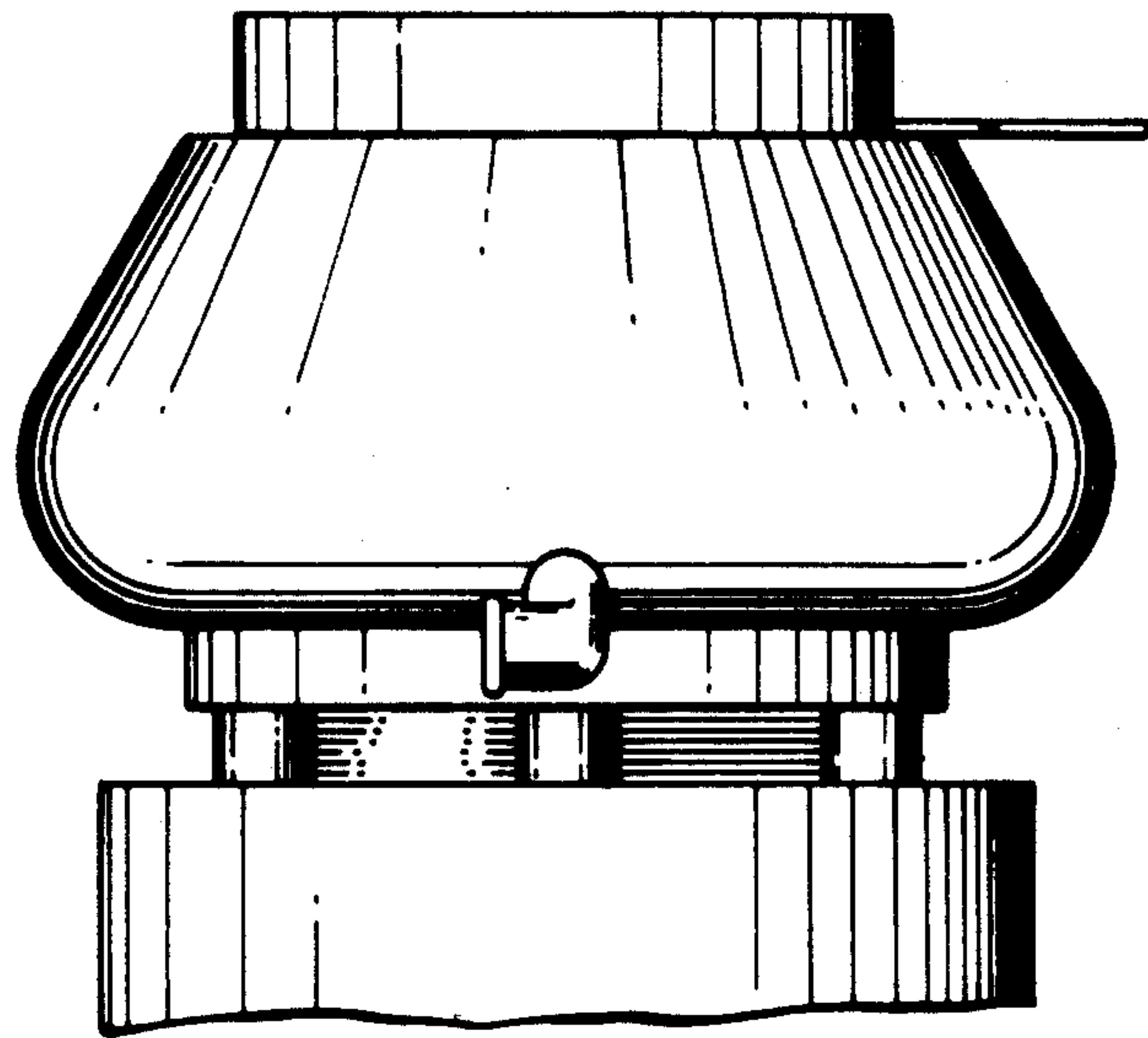

FIG. 5

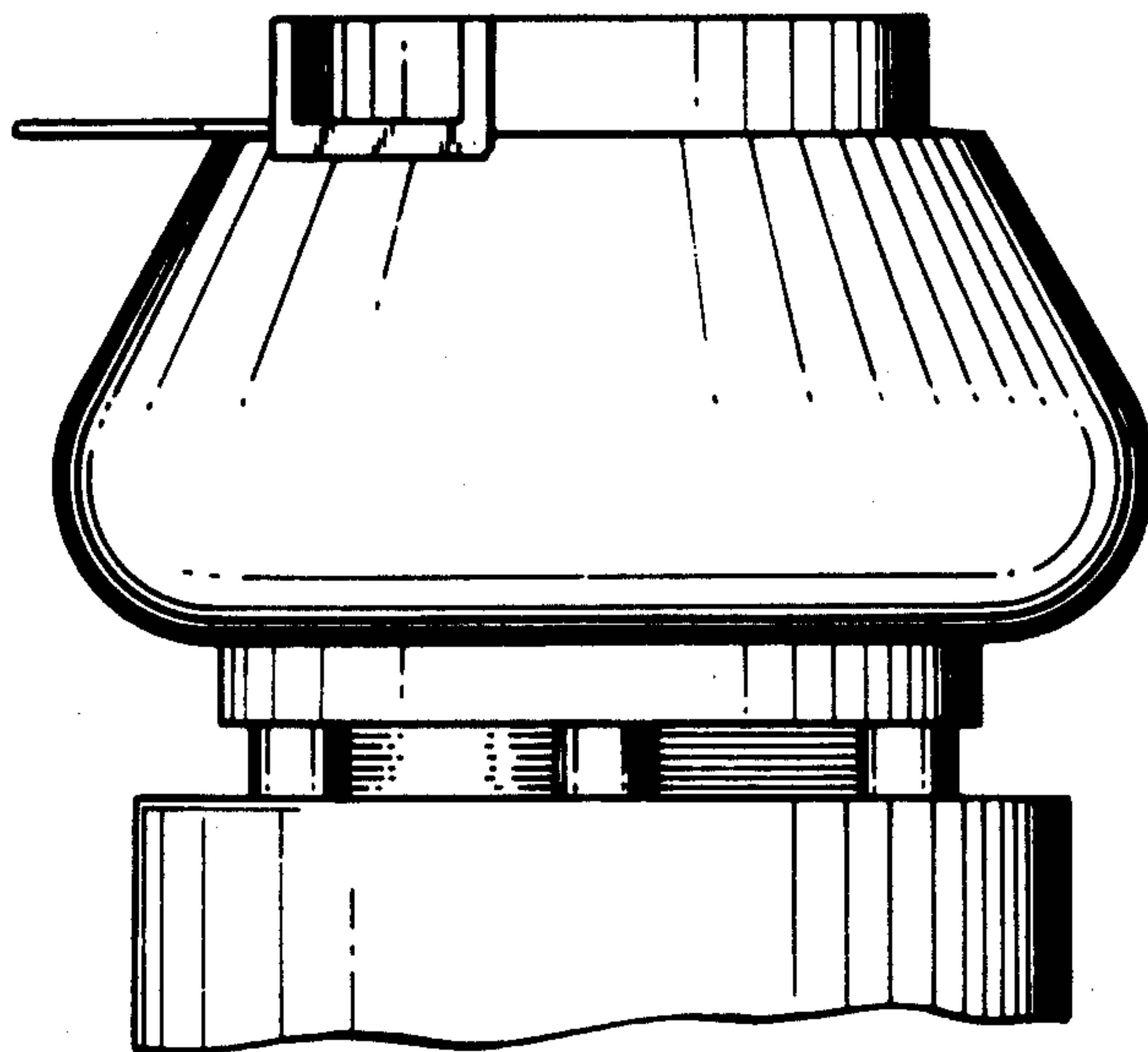
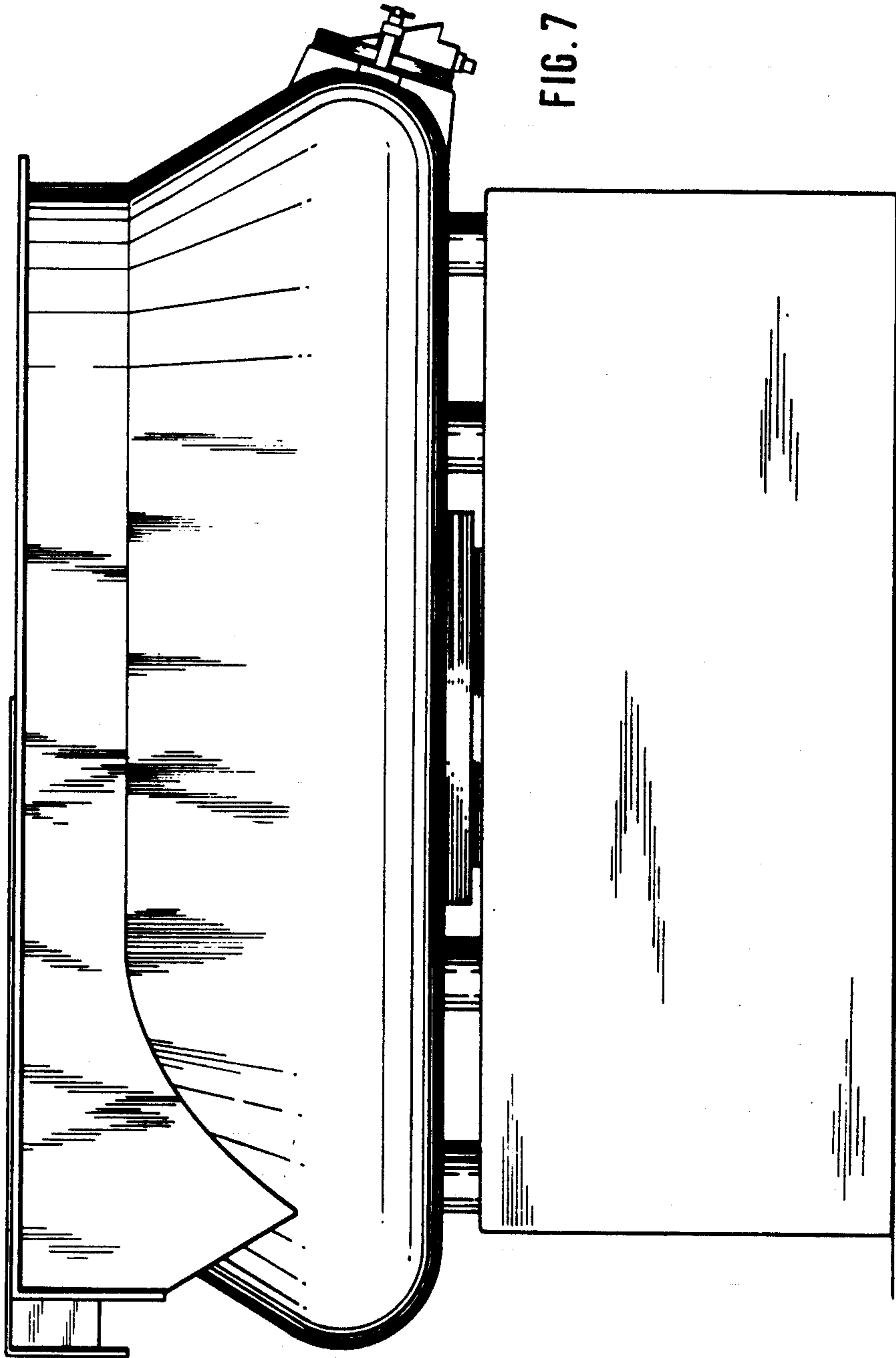

FIG. 6



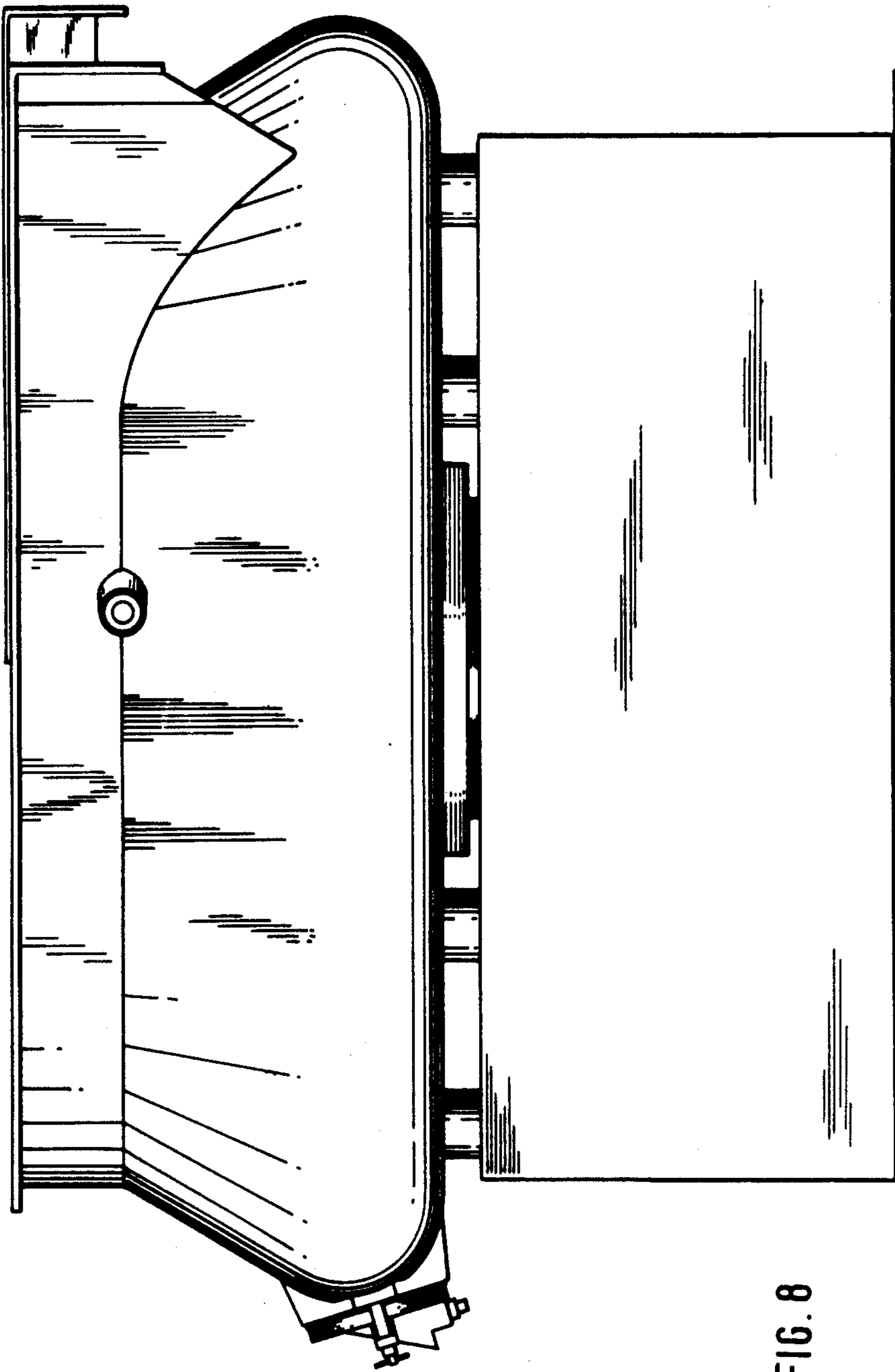

FIG. 8

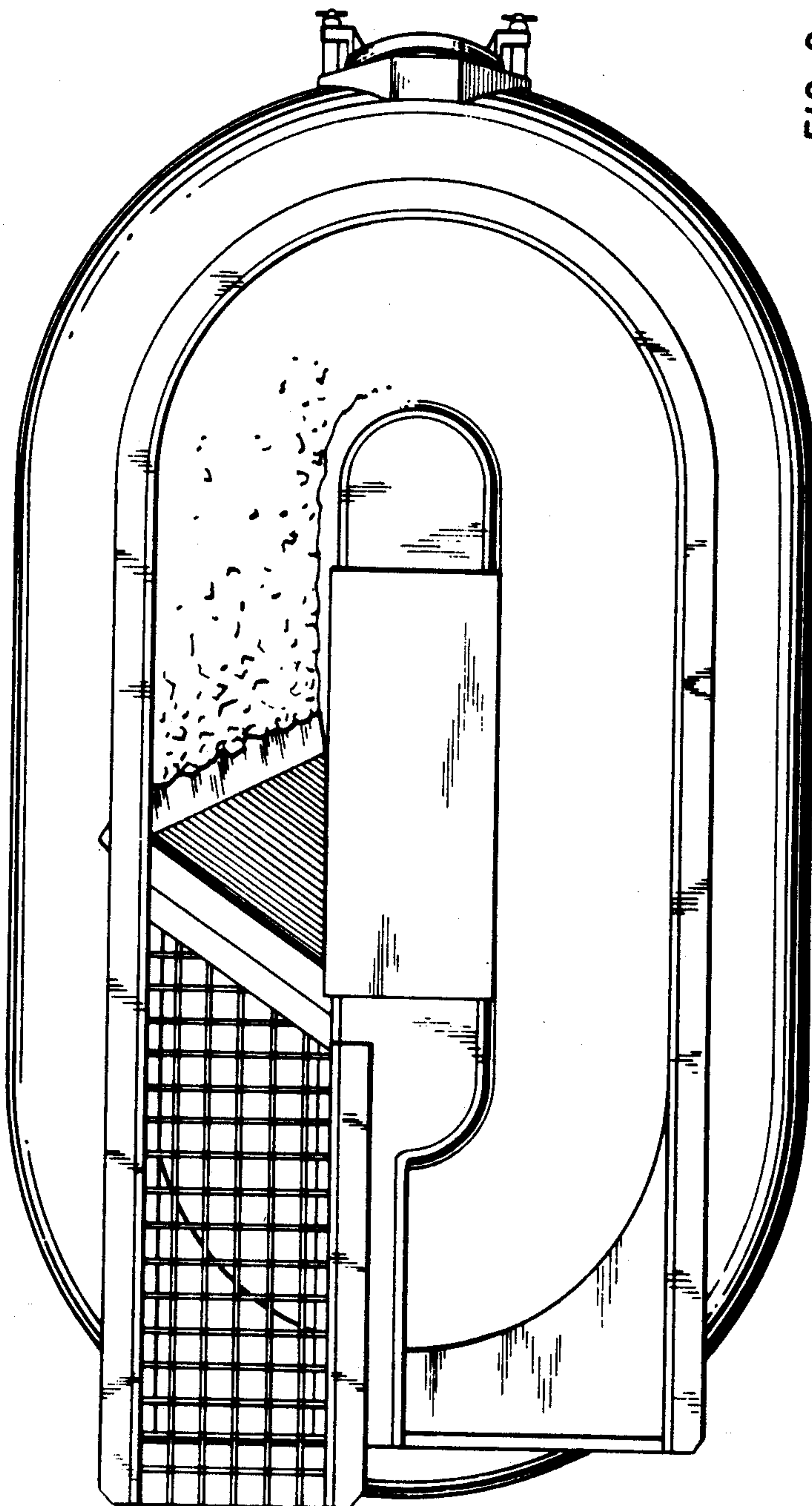

FIG. 9

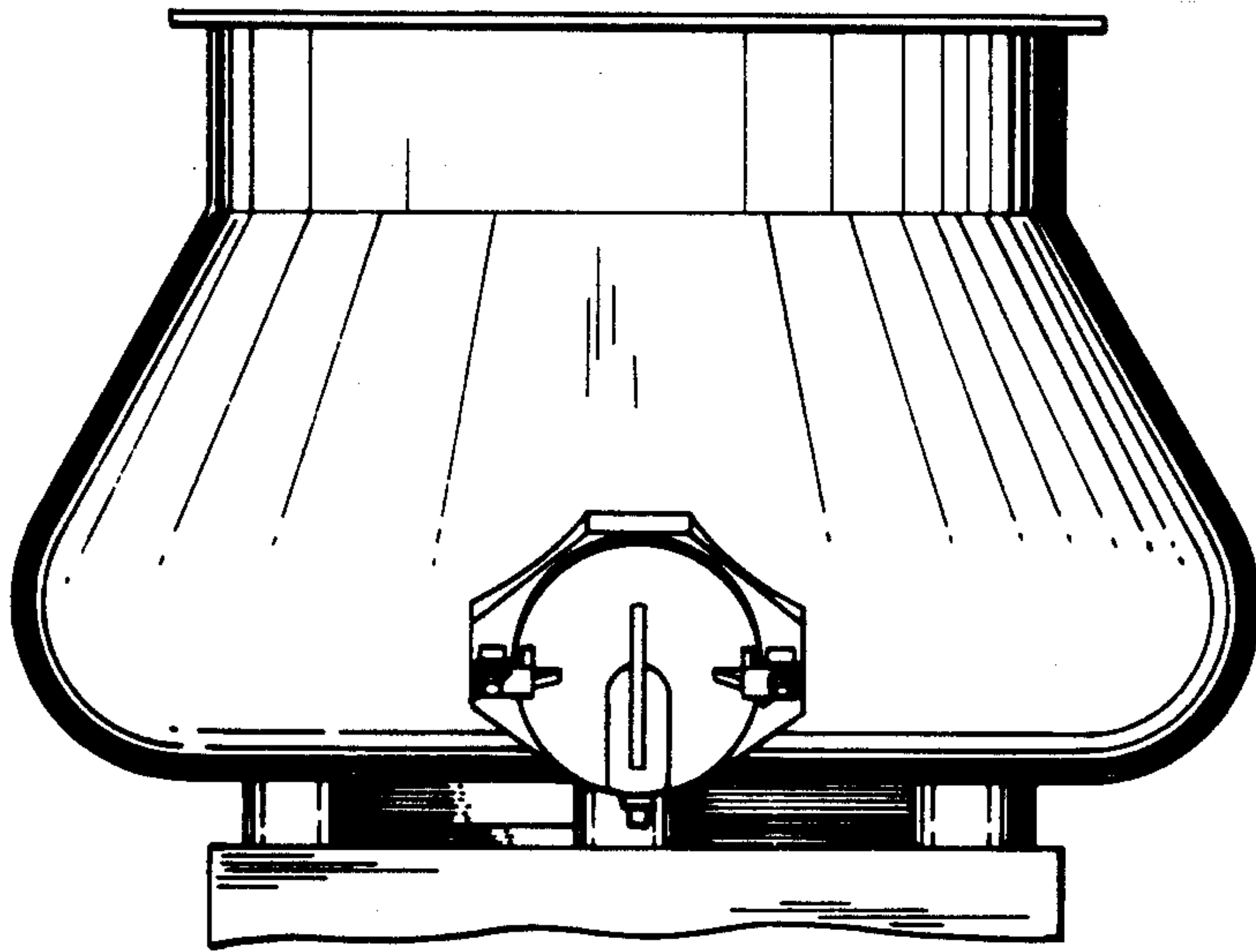

FIG. 10

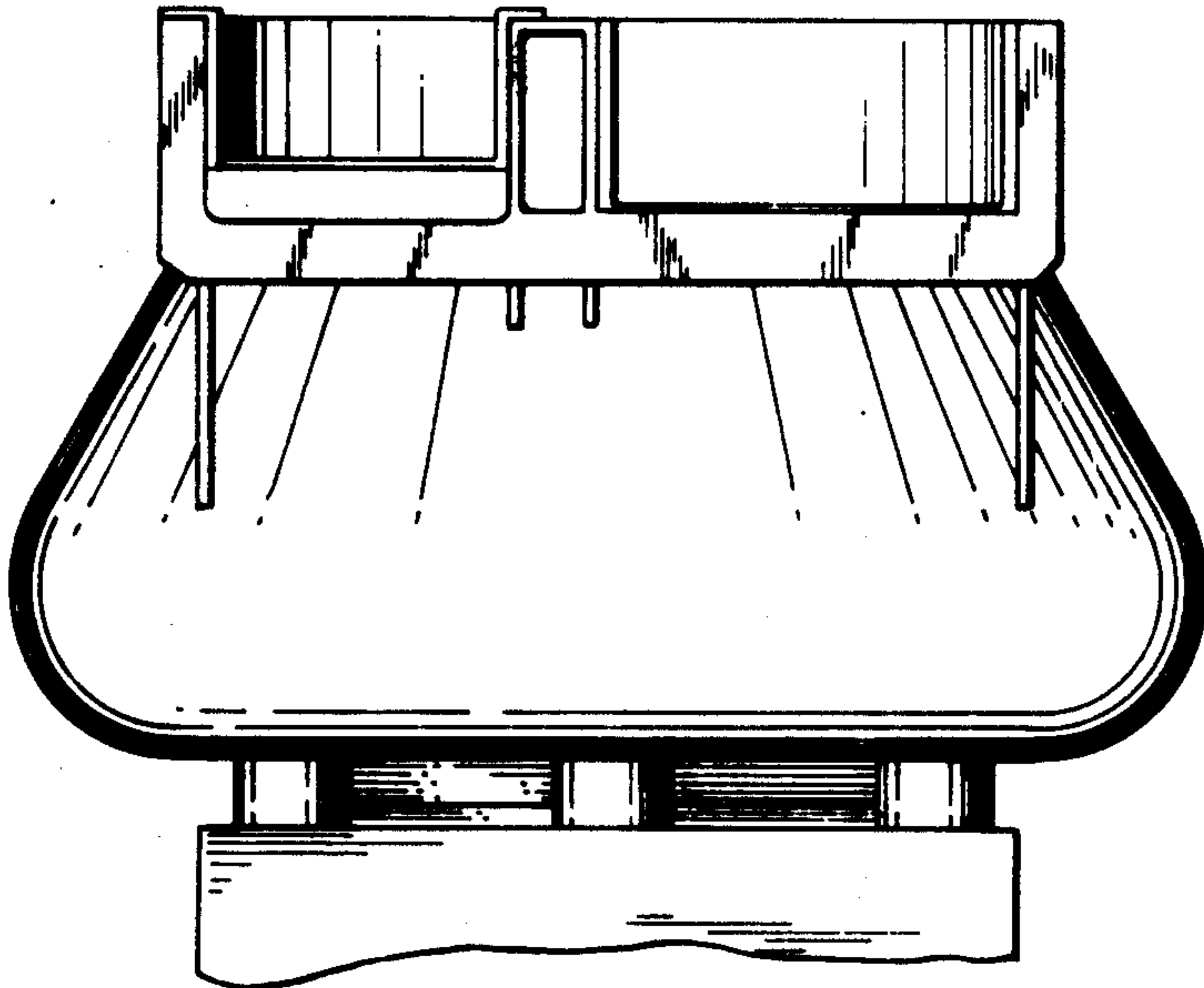

FIG. 11