

[54] PORTABLE ELECTRIC GRINDER

[75] Inventors: Masakazu Sakamoto; Tetsuyuki Doi, both of Fukuyama, Japan

[73] Assignee: Ryobi Ltd., Fuchu, Japan

[**] Term: 14 Years

[21] Appl. No.: 837,056

[22] Filed: Sep. 28, 1977

[30] Foreign Application Priority Data

May 16, 1977 [JP] Japan 52-18713

[51] Int. Cl. D8-02

[52] U.S. Cl. D8/62

[58] Field of Search D8/61-70;
51/170 R, 170 MT, 170 TL, 170 T, 134.5 F;
15/28, 97 R, 97 A

[56] References Cited
PUBLICATIONS

C. & E. Fein Enterprise; Electric Tool Catalog, p. 22.

Alberteson & Co., Inc.; Air and Electric "Sioux" Tools, Catalog No. 65, p. 49, Model No. 1250.

Sioux Tools Inc., Air and Electric Sioux Tools, Cat. No. 71, p. 56, Model No. 502.

Black & Decker Mfg. Co., Catalog 290, p. 29, Model No. 7960.

Primary Examiner—Peter Feldman
Attorney, Agent, or Firm—Sughrue, Rothwell, Mion, Zinn and Macpeak

[57] CLAIM

The ornamental design for a portable electric grinder, as shown.

DESCRIPTION

FIG. 1 is a front, top and right side perspective view of a portable electric grinder showing our new design;

FIG. 2 is a rear, bottom and left side perspective view thereof;

FIG. 3 is a right side view thereof;

FIG. 4 is a left side view thereof;

FIG. 5 is a front view thereof;

FIG. 6 is a rear view thereof;

FIG. 7 is a top plan view thereof; and

FIG. 8 is a bottom plan view thereof.

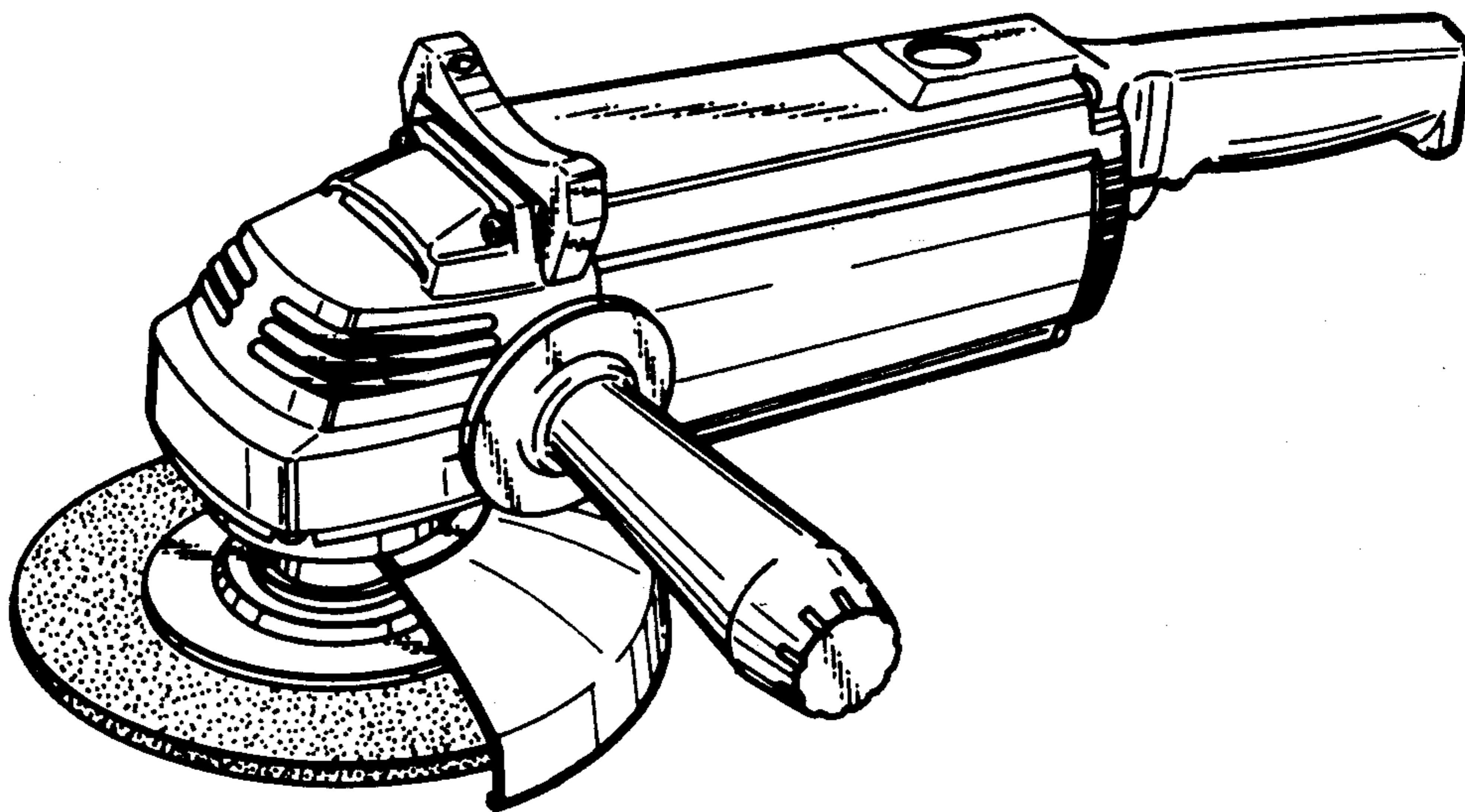

Fig. 1

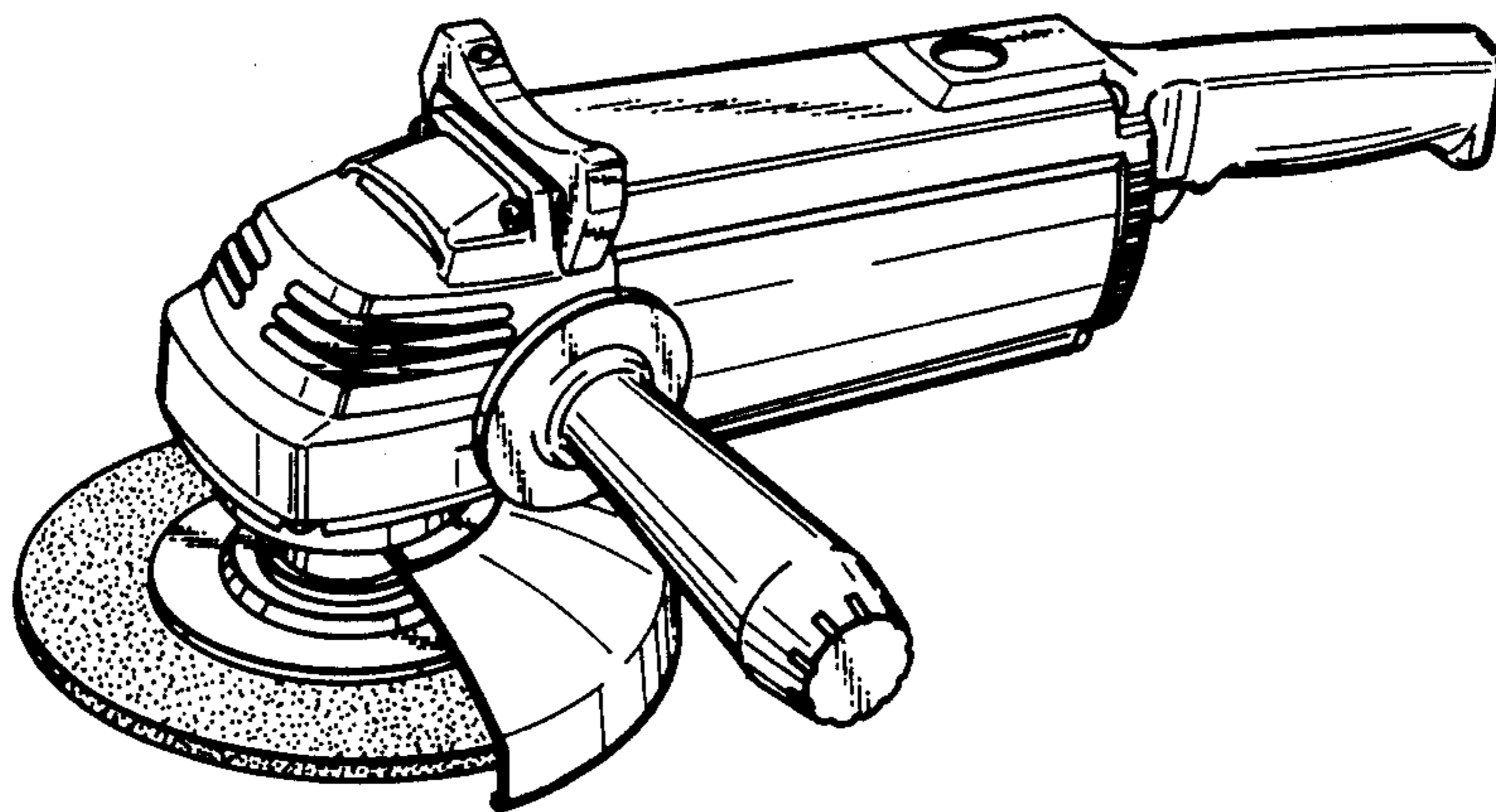

Fig. 2

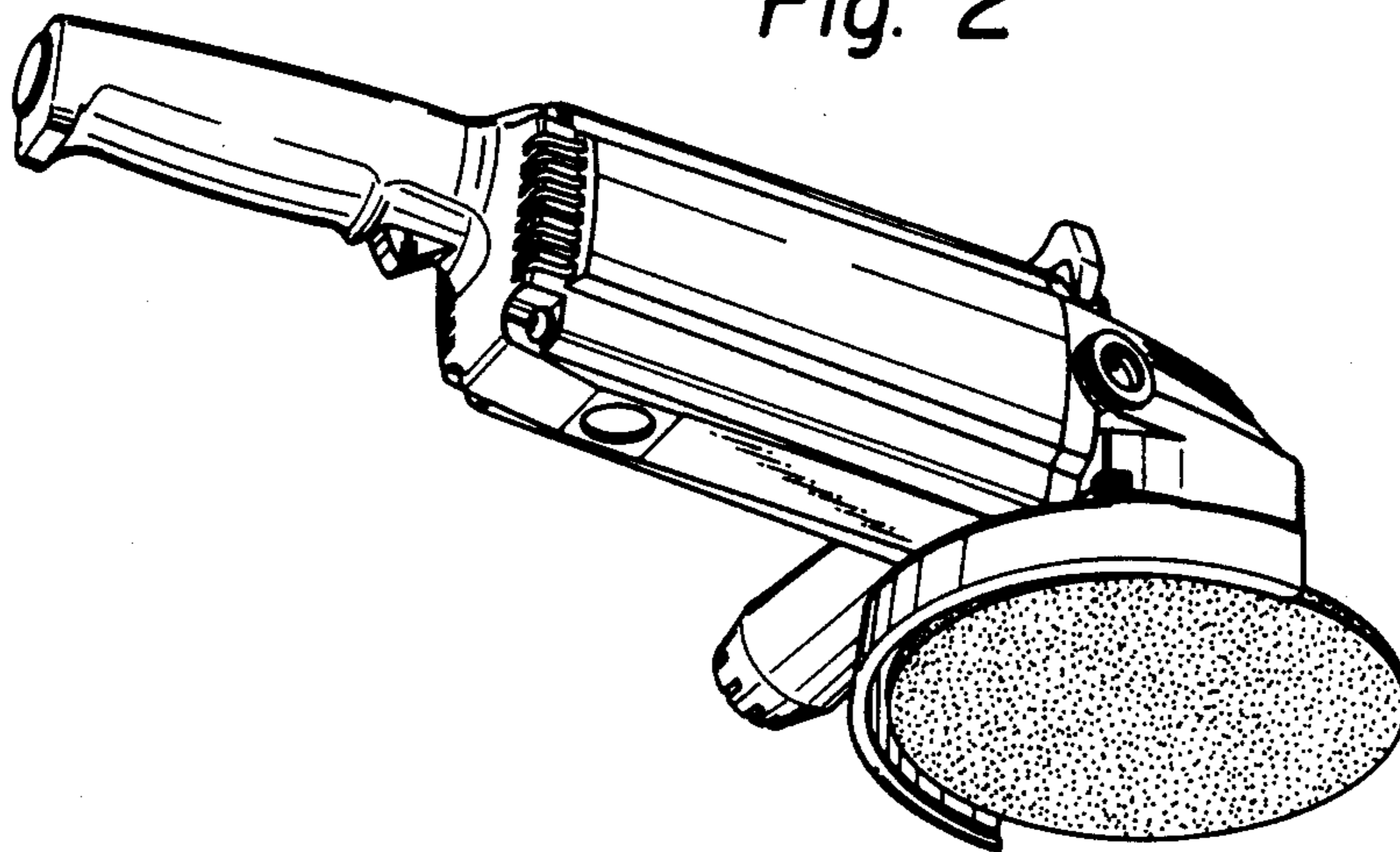

Fig. 3

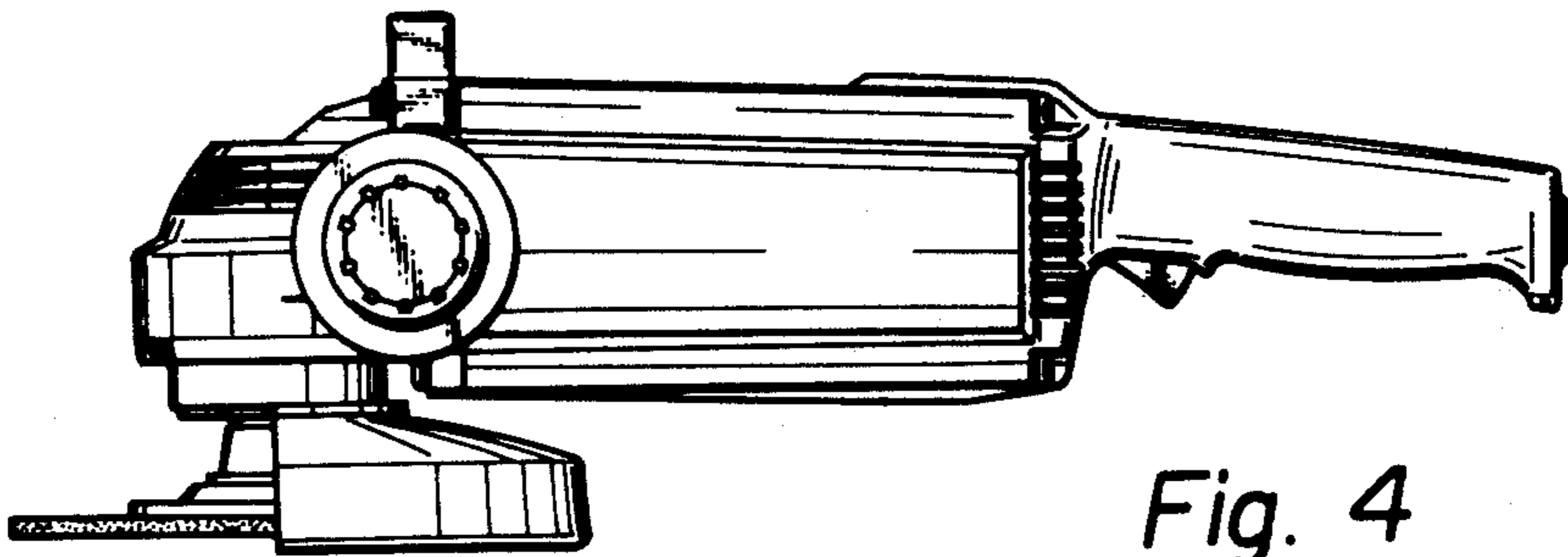

Fig. 4

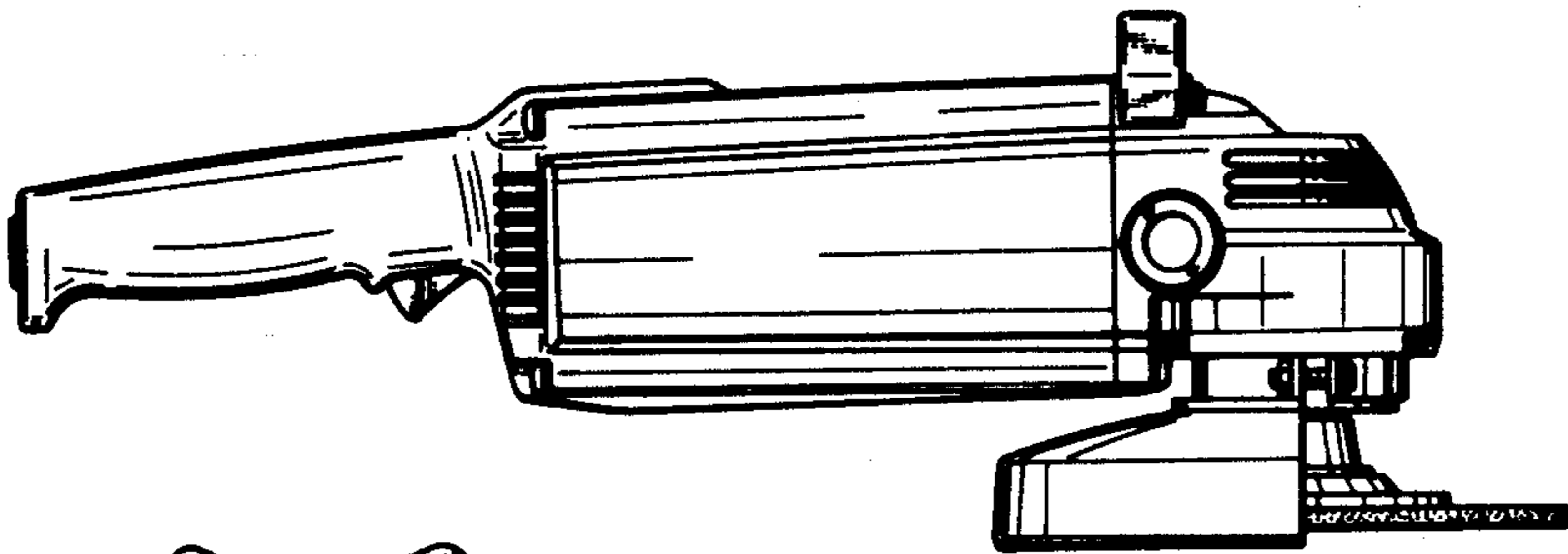

Fig. 5

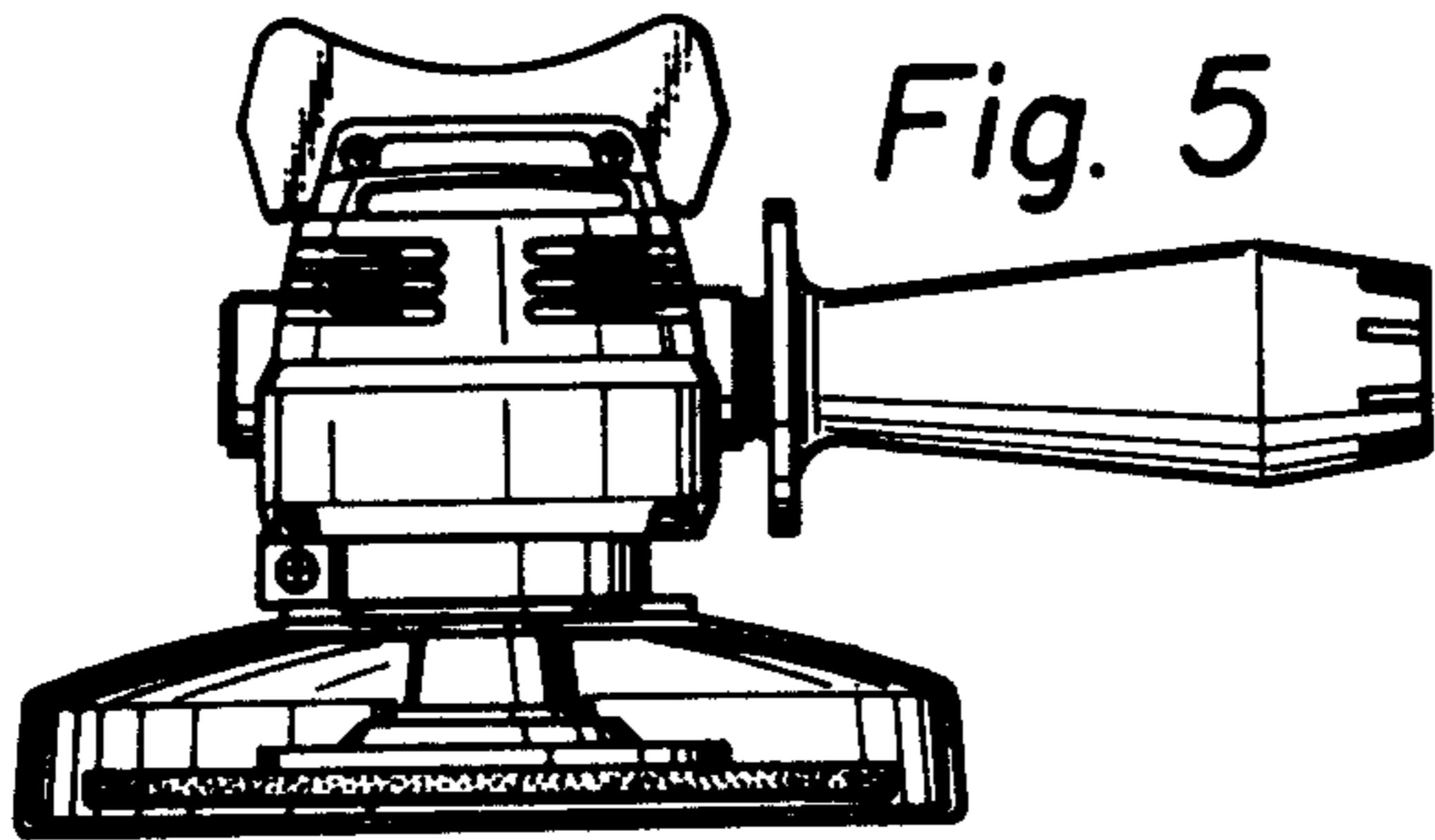

Fig. 6

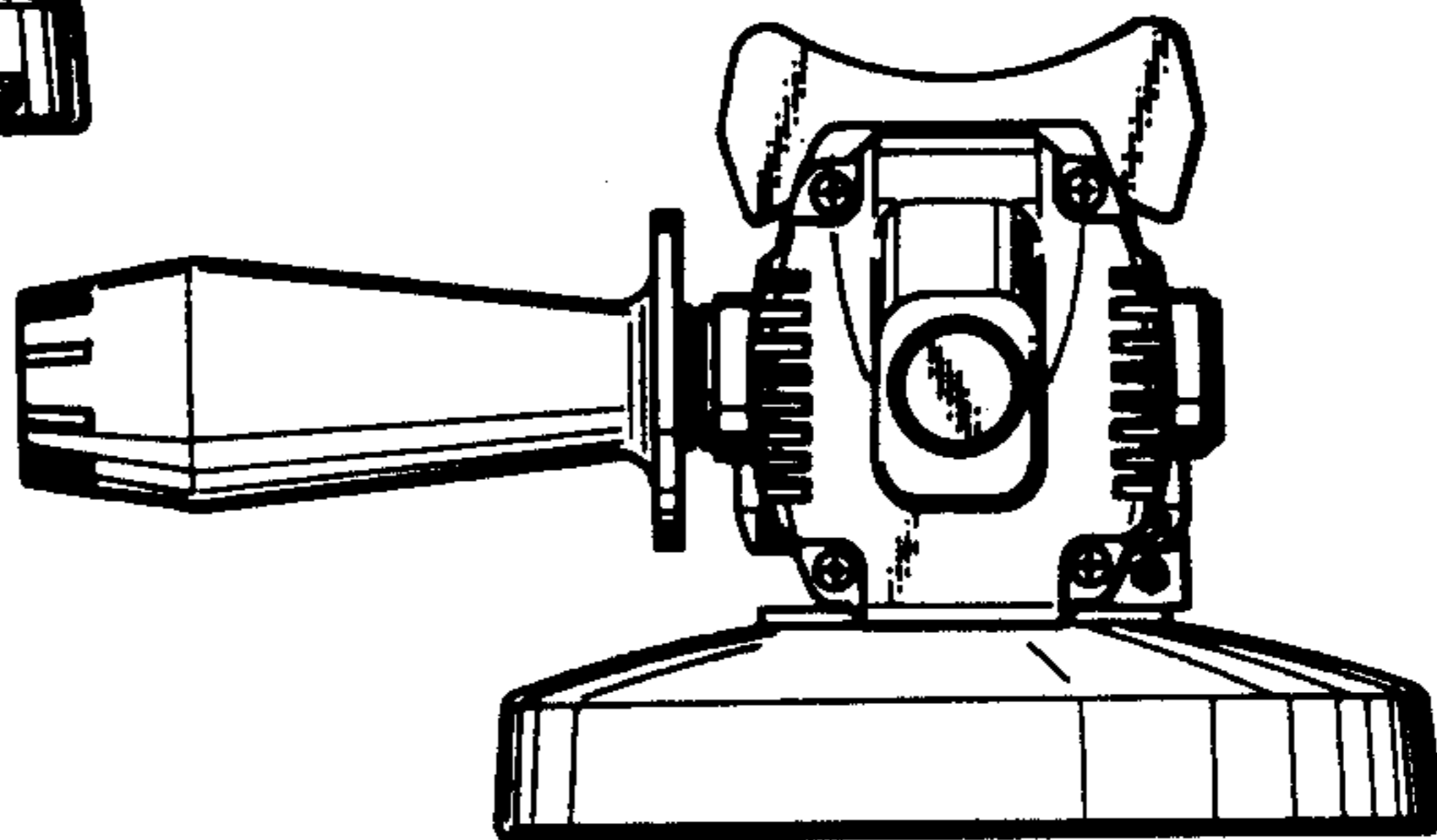

Fig. 7

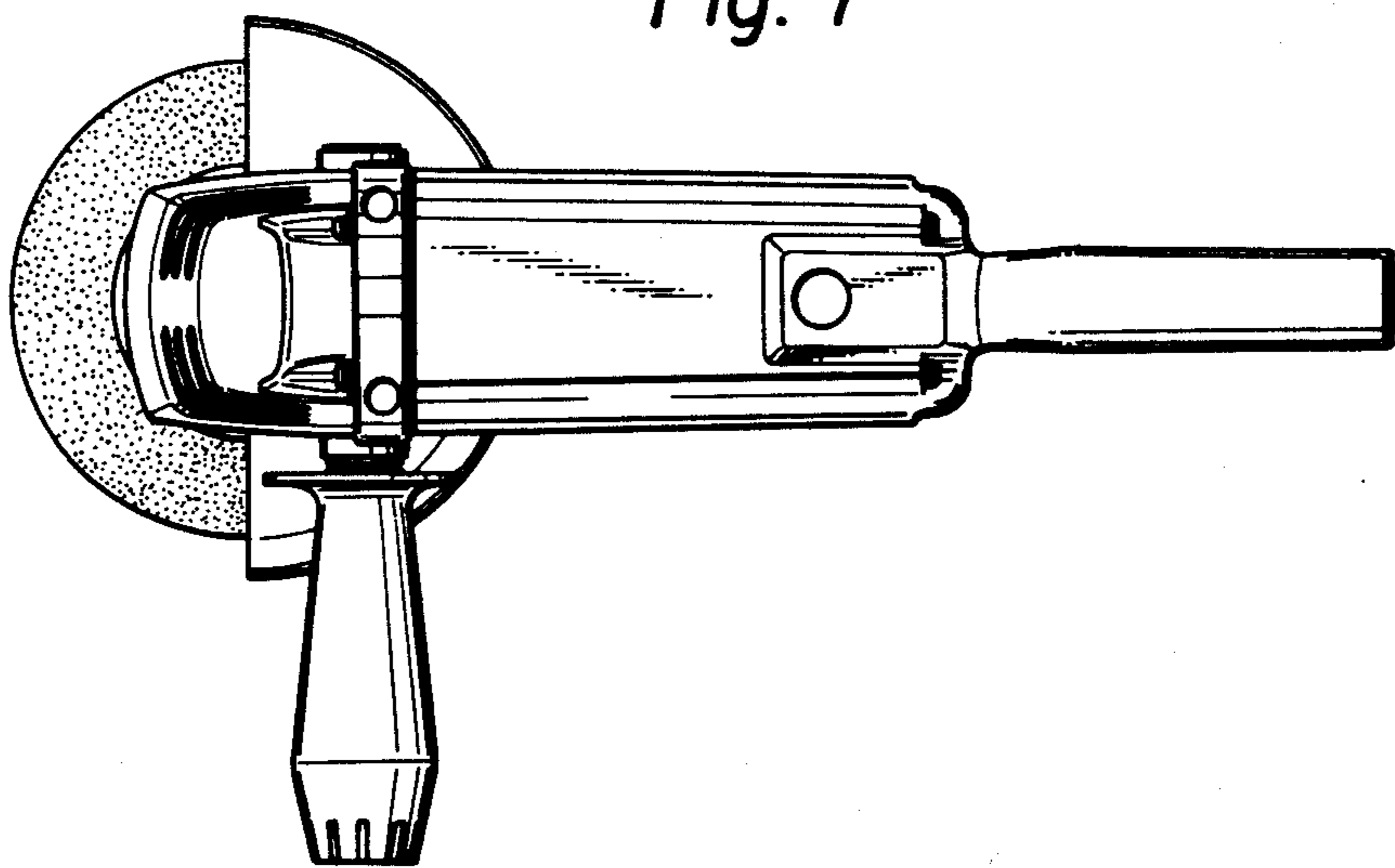

Fig. 8

