

[54] AFTER-COOLER FOR SUPERCHARGER FOR INTERNAL COMBUSTION ENGINE

[76] Inventor: Robert L. Ullrich, P.O. Box 899, Roswell, N. Mex. 88201

[**] Term: 14 Years

[21] Appl. No.: 851,324

[22] Filed: Nov. 14, 1977

[51] Int. Cl. D15-01

[52] U.S. Cl. D15/5

[58] Field of Search D15/5; 123/119 CD, 119 C; 261/DIG. 51

[56] References Cited

U.S. PATENT DOCUMENTS

3,881,455 5/1975 Belsanti 123/119 C

4,028,892 6/1977 Hinkle 123/119 CD

Primary Examiner—James M. Gandy
Attorney, Agent, or Firm—Sughrue, Rothwell, Mion, Zinn and Macpeak

[57] CLAIM

The ornamental design for after-cooler for supercharger for internal combustion engine, as shown.

DESCRIPTION

FIG. 1 is a perspective view of an after-cooler for supercharger for internal combustion engine showing my new design;

FIG. 2 is a top plan view thereof;

FIG. 3 is a side elevational view thereof opposite to that shown in FIG. 1;

FIG. 4 is an end elevational view thereof opposite to that shown in FIG. 1; and

FIG. 5 is a bottom plan view thereof.

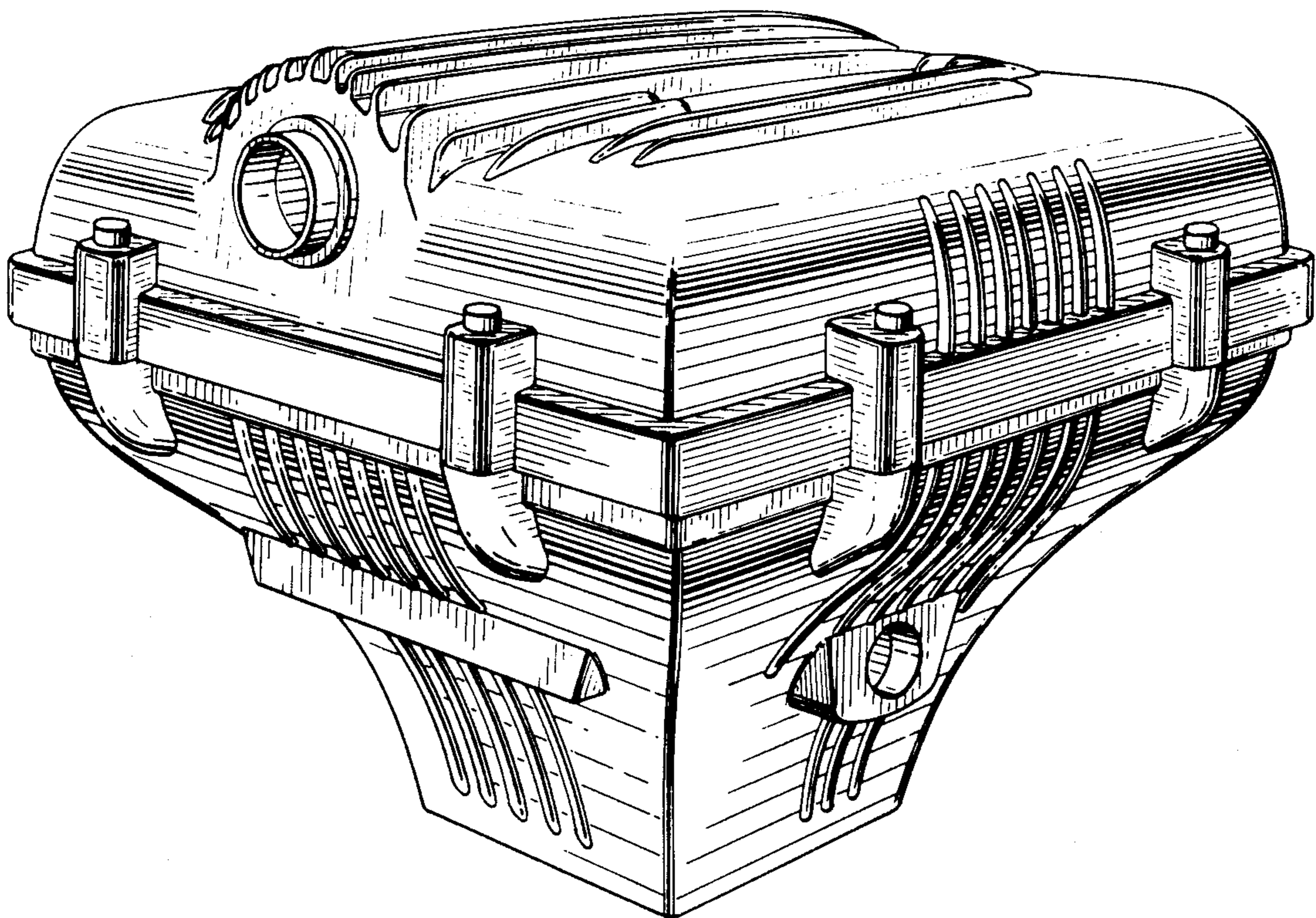

FIG. 1

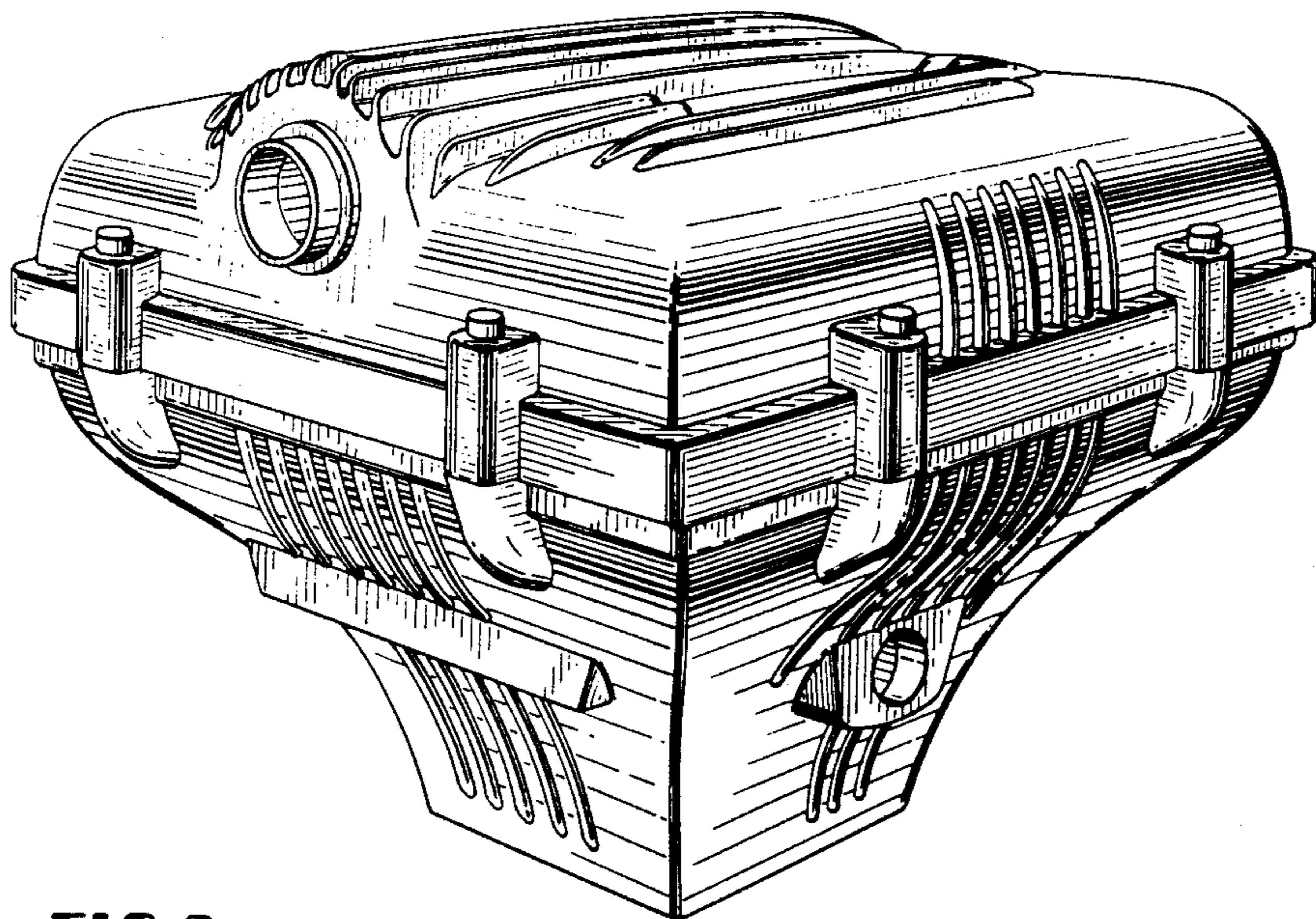
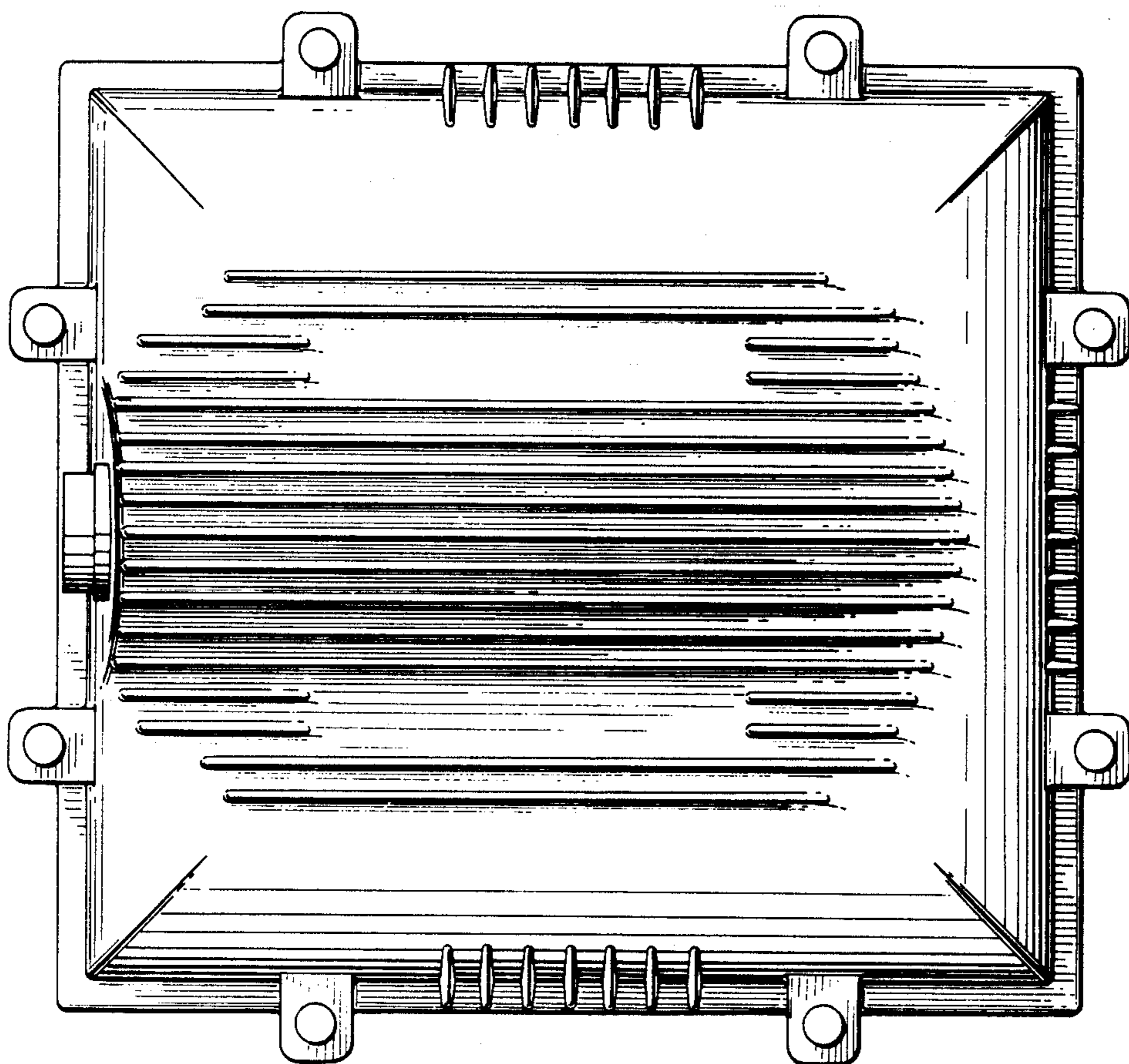

FIG. 2



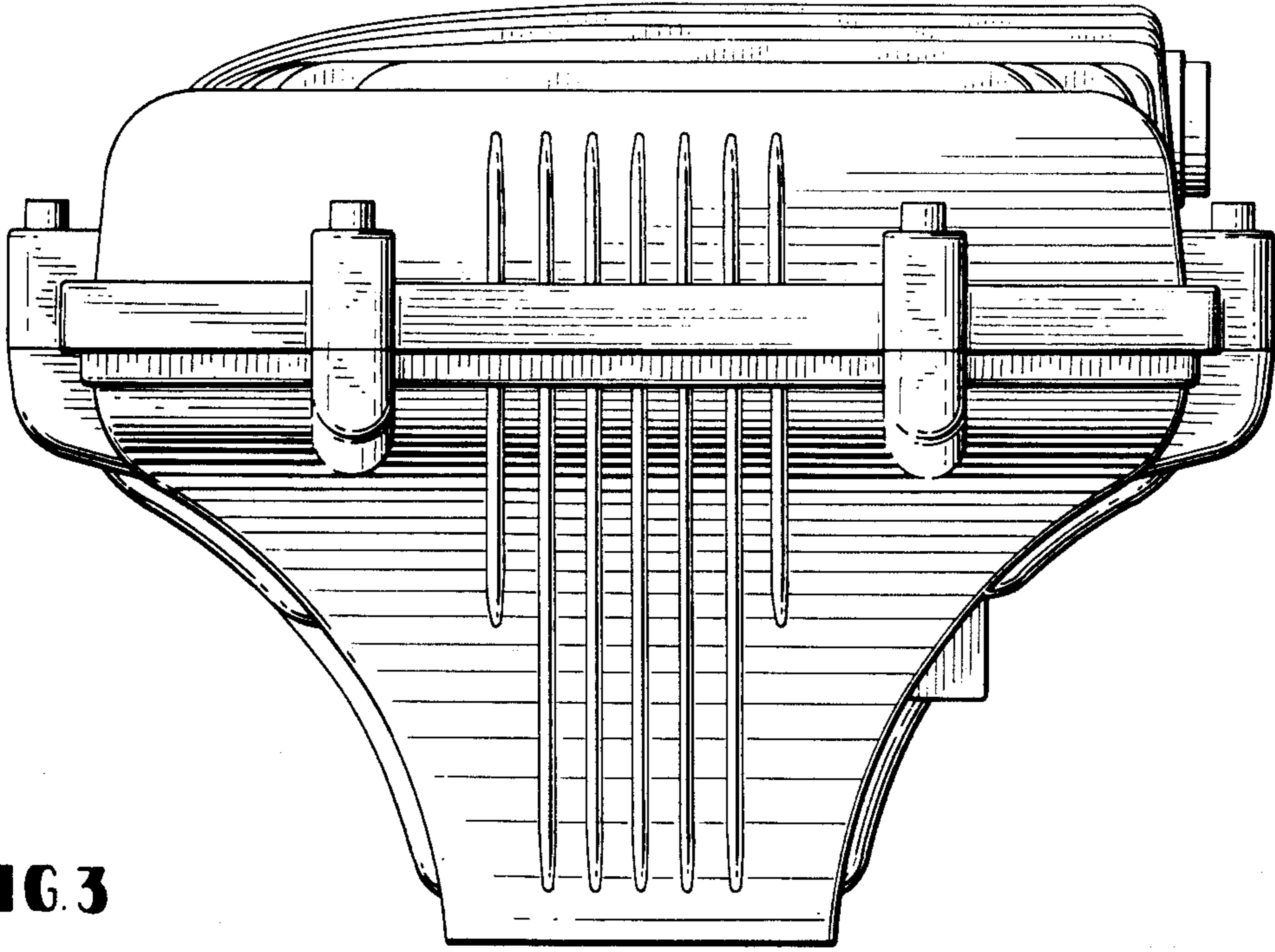

FIG. 3

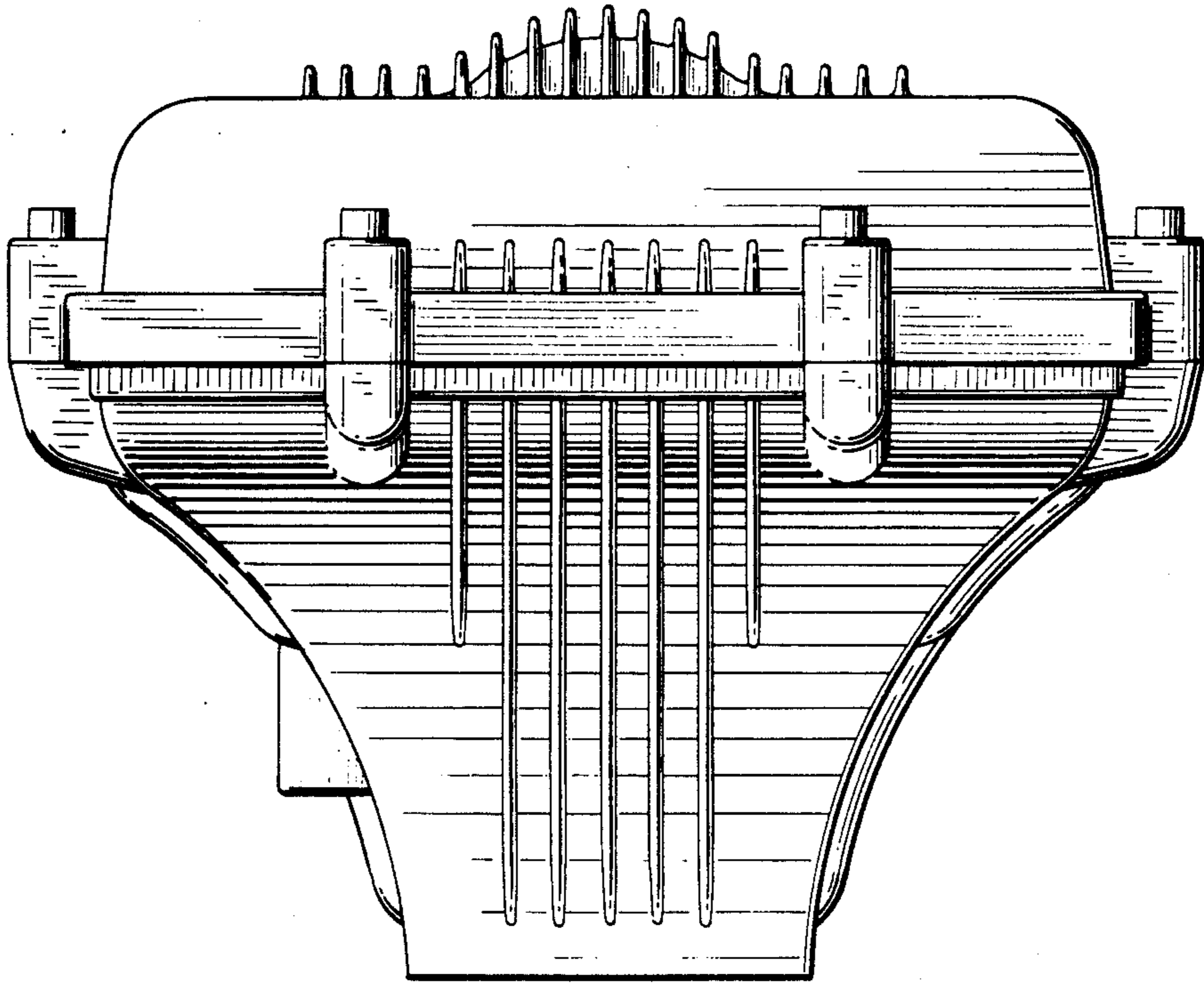

FIG. 4

FIG. 5

