

[54] AIRCRAFT

[76] Inventor: Peter Dornier, Schachenerstrasse 97, Lindau, Fed. Rep. of Germany, 8990

[\*\*] Term: 14 Years

[21] Appl. No.: 849,488

[22] Filed: Nov. 7, 1977

[51] Int. Cl. .... D12-07

[52] U.S. Cl. .... D12/75; D12/71

[58] Field of Search .... D12/75, 78, 71; 244/45 R, 55 R

[56]

References Cited

U.S. PATENT DOCUMENTS

D. 147,875 11/1947 Shannon ..... 244/45 R  
D. 232,710 9/1974 Moore ..... D12/75

Primary Examiner—Sam Rosen  
Attorney, Agent, or Firm—James E. Bryan

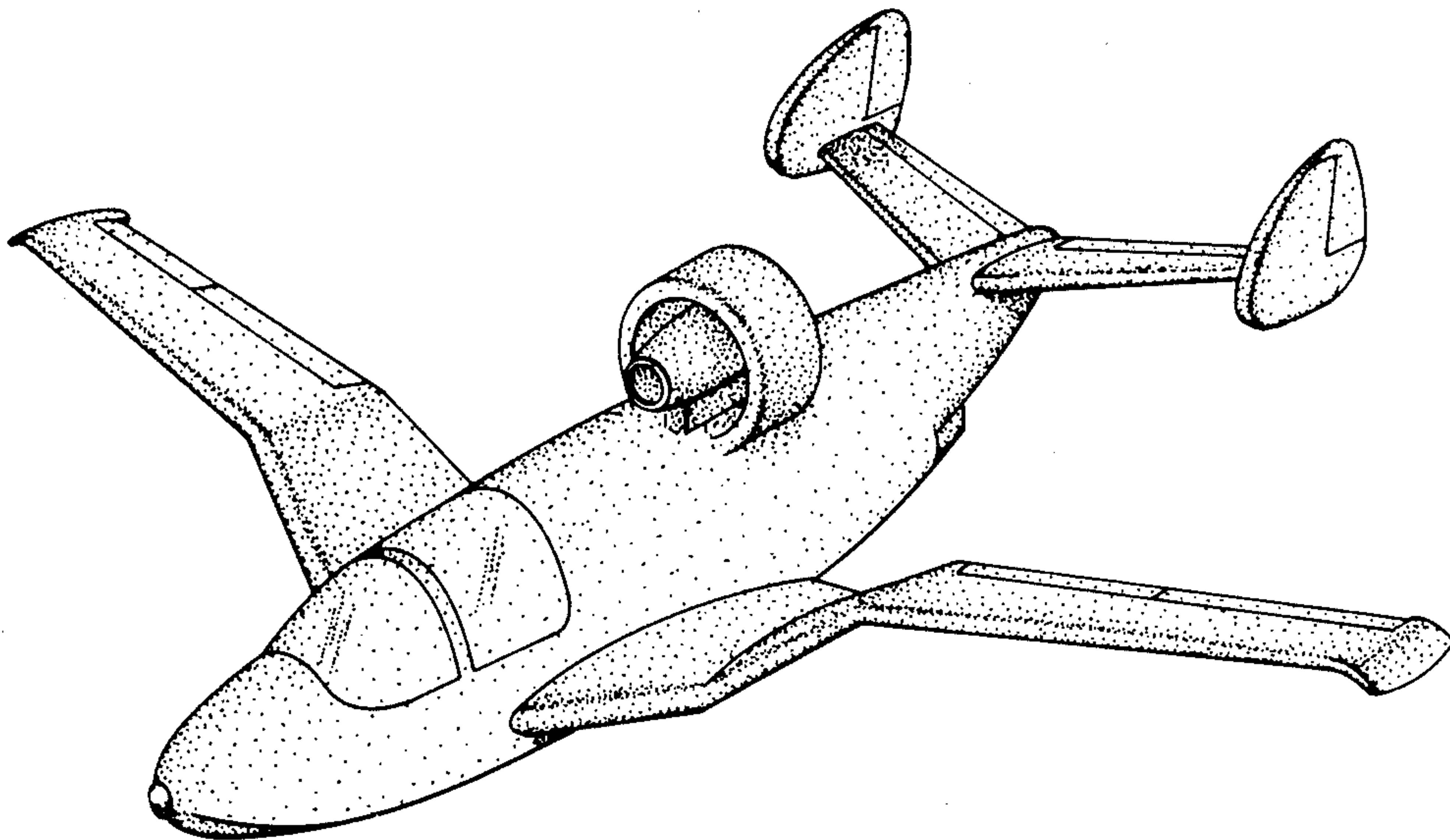
[57]

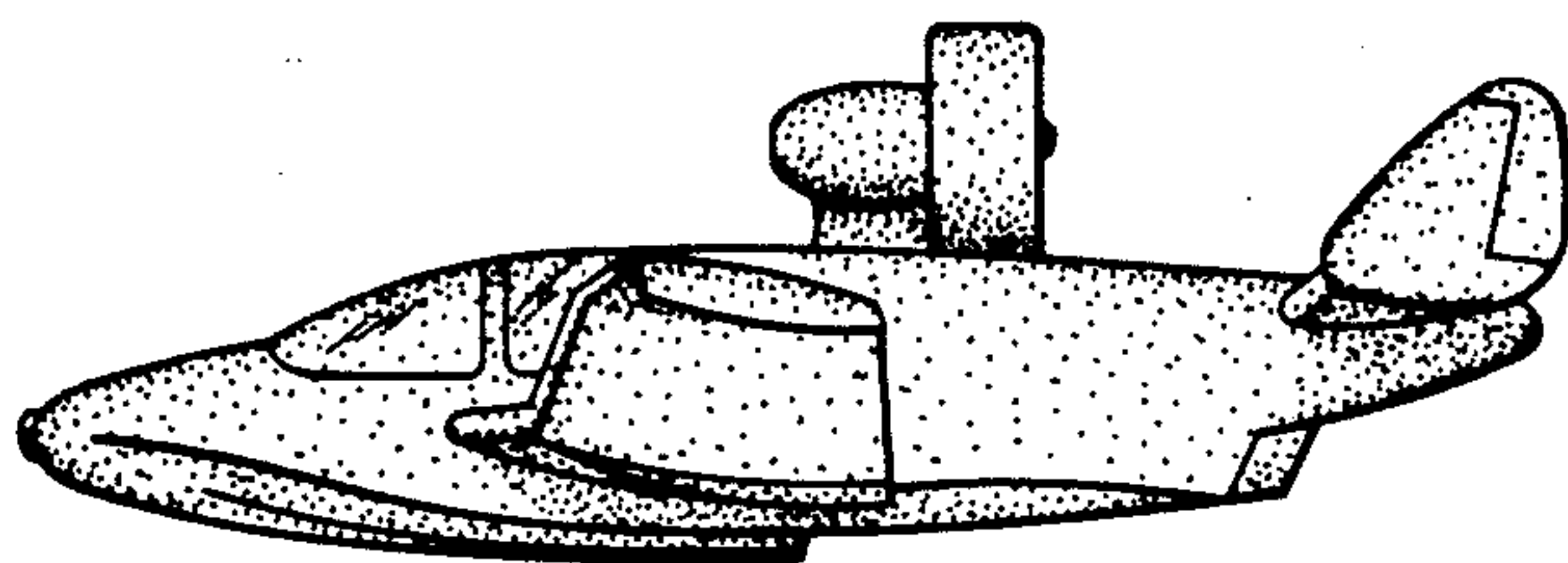
CLAIM

The ornamental design for an aircraft, substantially as shown and described.

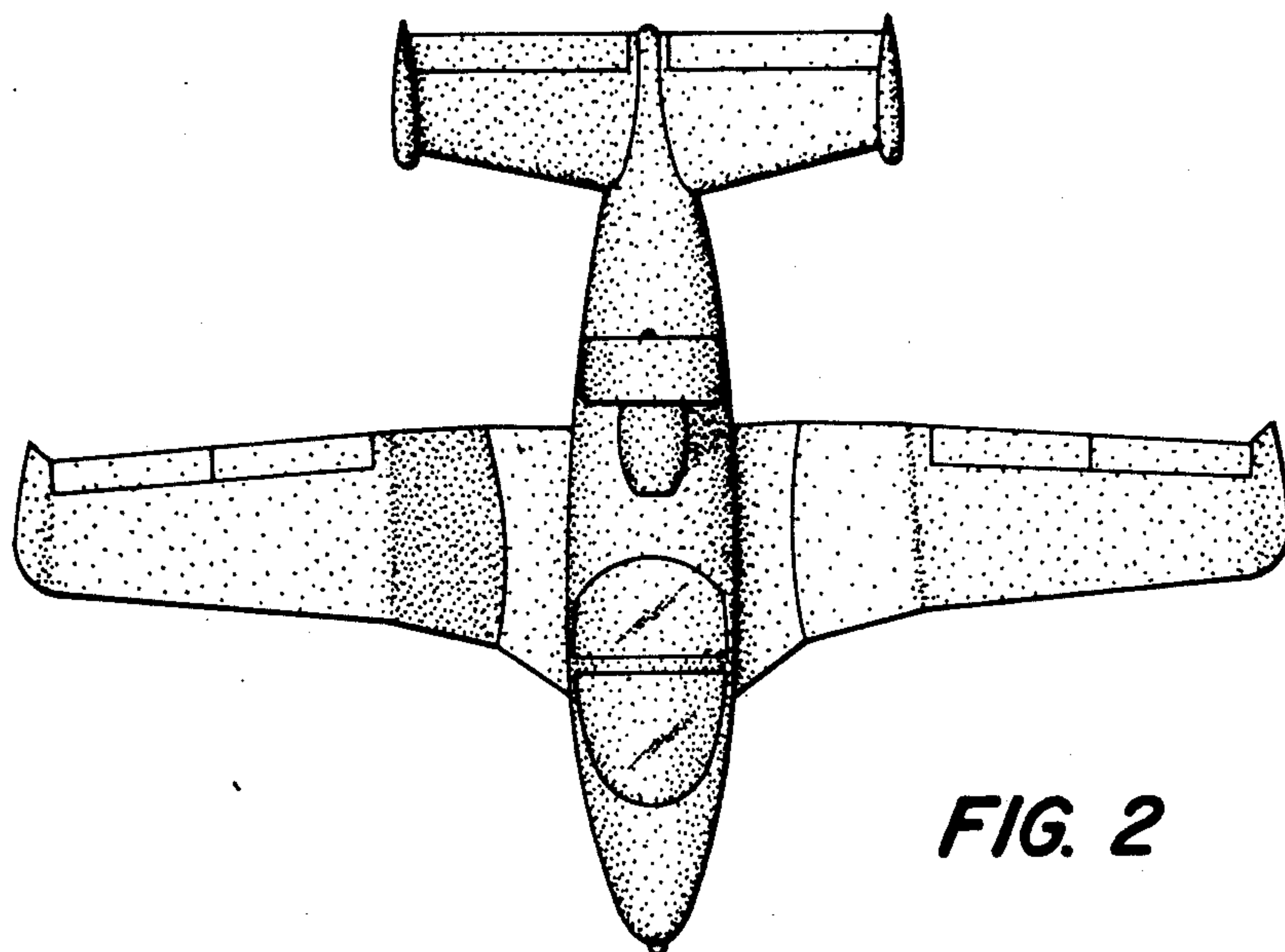
DESCRIPTION

FIG. 1 is a side view in elevation showing my aircraft, FIG. 2 is a top plan view thereof, FIG. 3 is a front view thereof, FIG. 4 is a perspective view thereof, FIG. 5 is a bottom view thereof, and FIG. 6 is a rear view thereof.

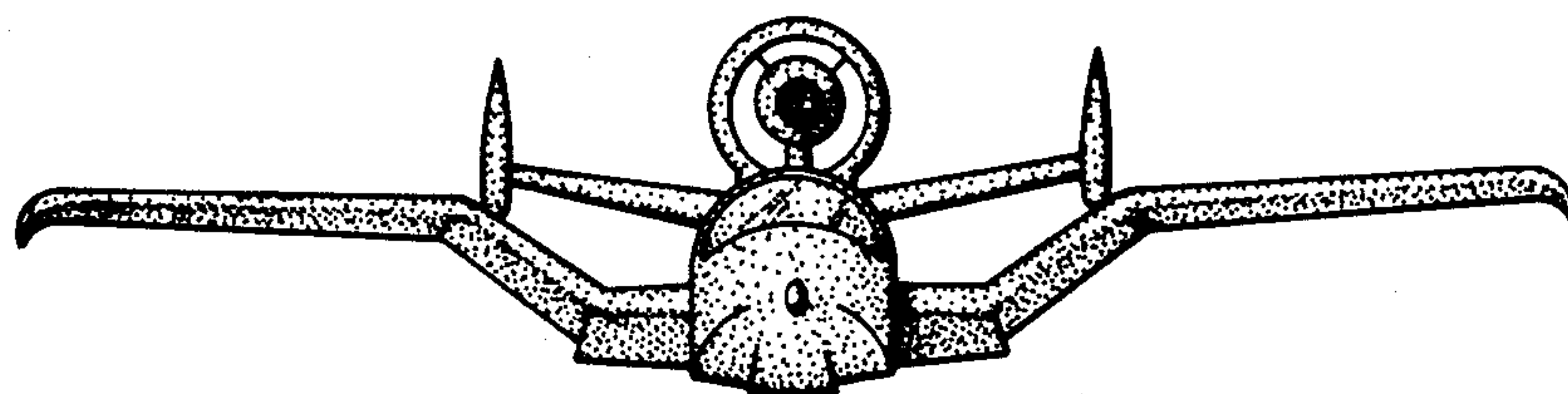




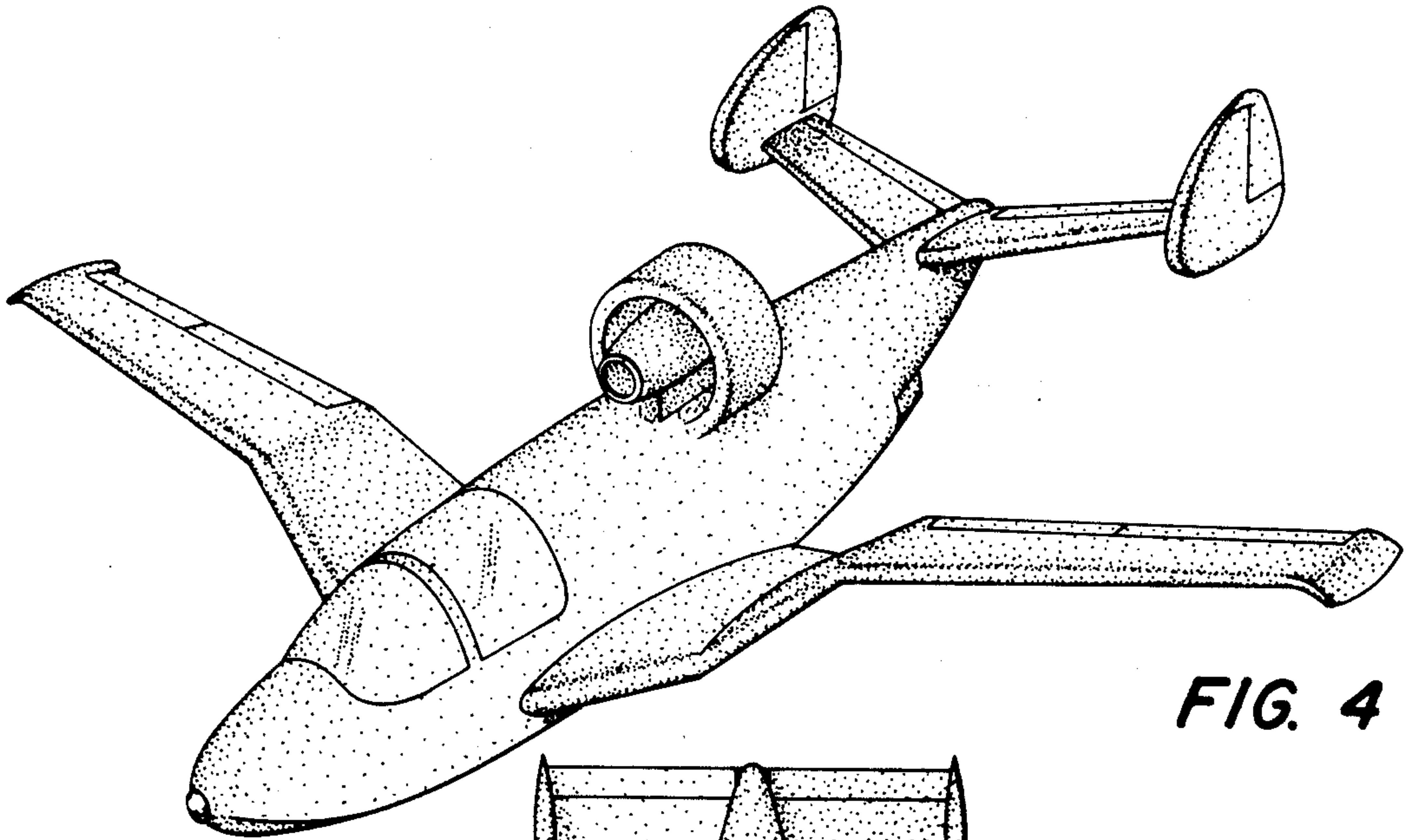
**FIG. 1**



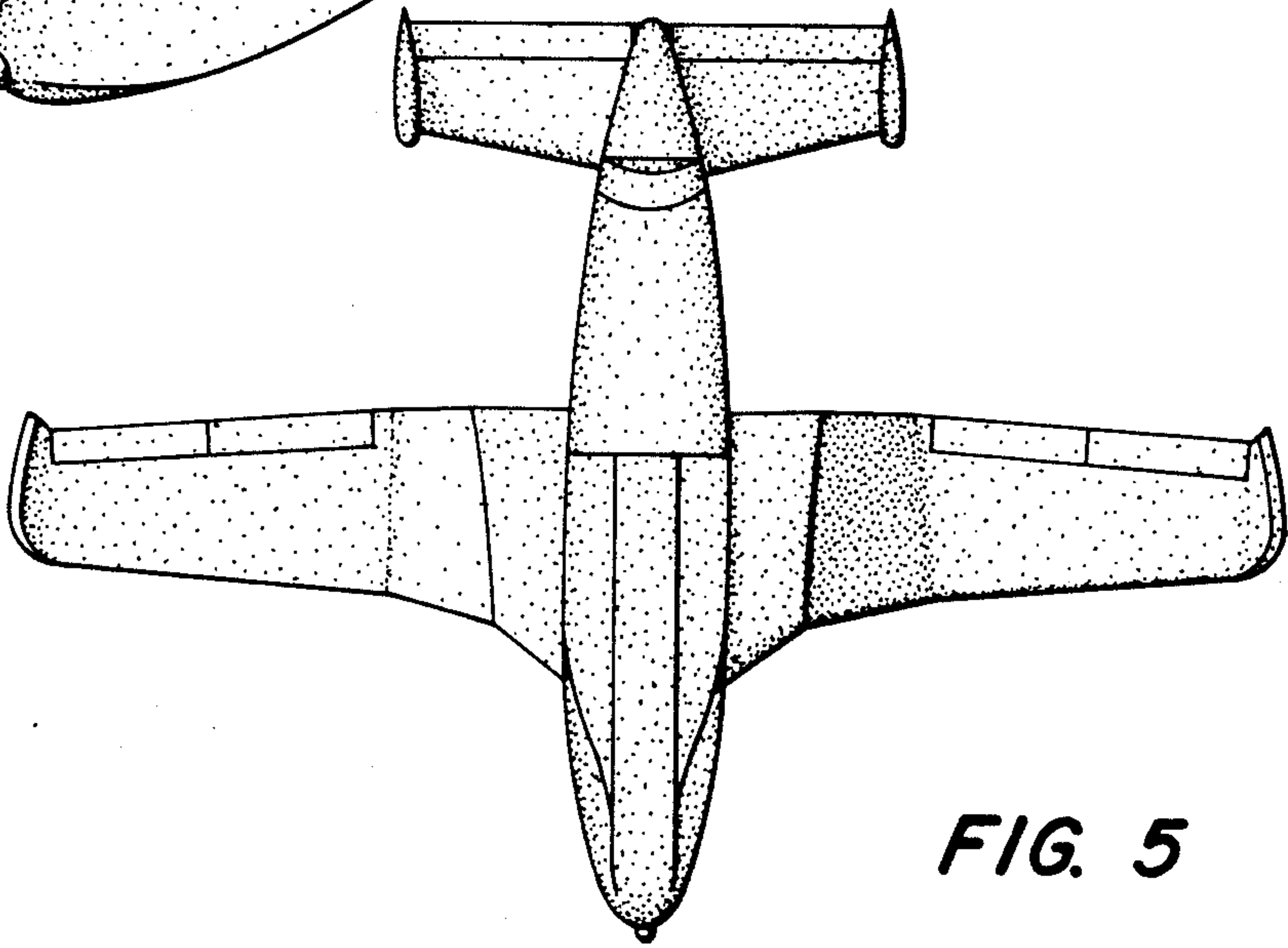
**FIG. 2**



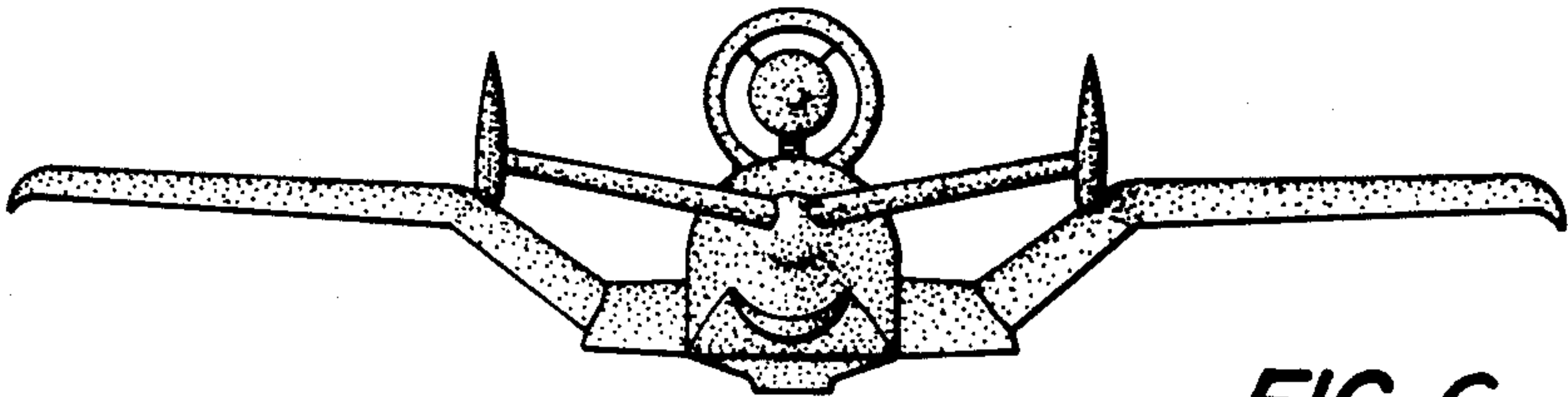
**FIG. 3**



**FIG. 4**



**FIG. 5**



**FIG. 6**