

[54] AIRCRAFT

[76] Inventor: Peter Dornier, Schachenerstrasse 97, Lindau, Fed. Rep. of Germany, 8990

[**] Term: 14 Years

[21] Appl. No.: 849,486

[22] Filed: Nov. 7, 1977

[51] Int. Cl. D12-07

[52] U.S. Cl. D12/75; D12/71

[58] Field of Search D12/71, 75, 78; 244/45 R, 55 R

[56] References Cited

U.S. PATENT DOCUMENTS

D. 147,875 11/1947 Shannon 244/45 R
D. 232,710 9/1974 Moore D12/75

Primary Examiner—Sam Rosen
Attorney, Agent, or Firm—James E. Bryan

[57] CLAIM

The ornamental design for an aircraft, substantially as shown and described.

DESCRIPTION

FIG. 1 is a side view in elevation showing my aircraft, FIG. 2 is a top plan view thereof, FIG. 3 is a front view thereof, FIG. 4 is a perspective view thereof, FIG. 5 is a bottom view thereof, and FIG. 6 is a rear view thereof.

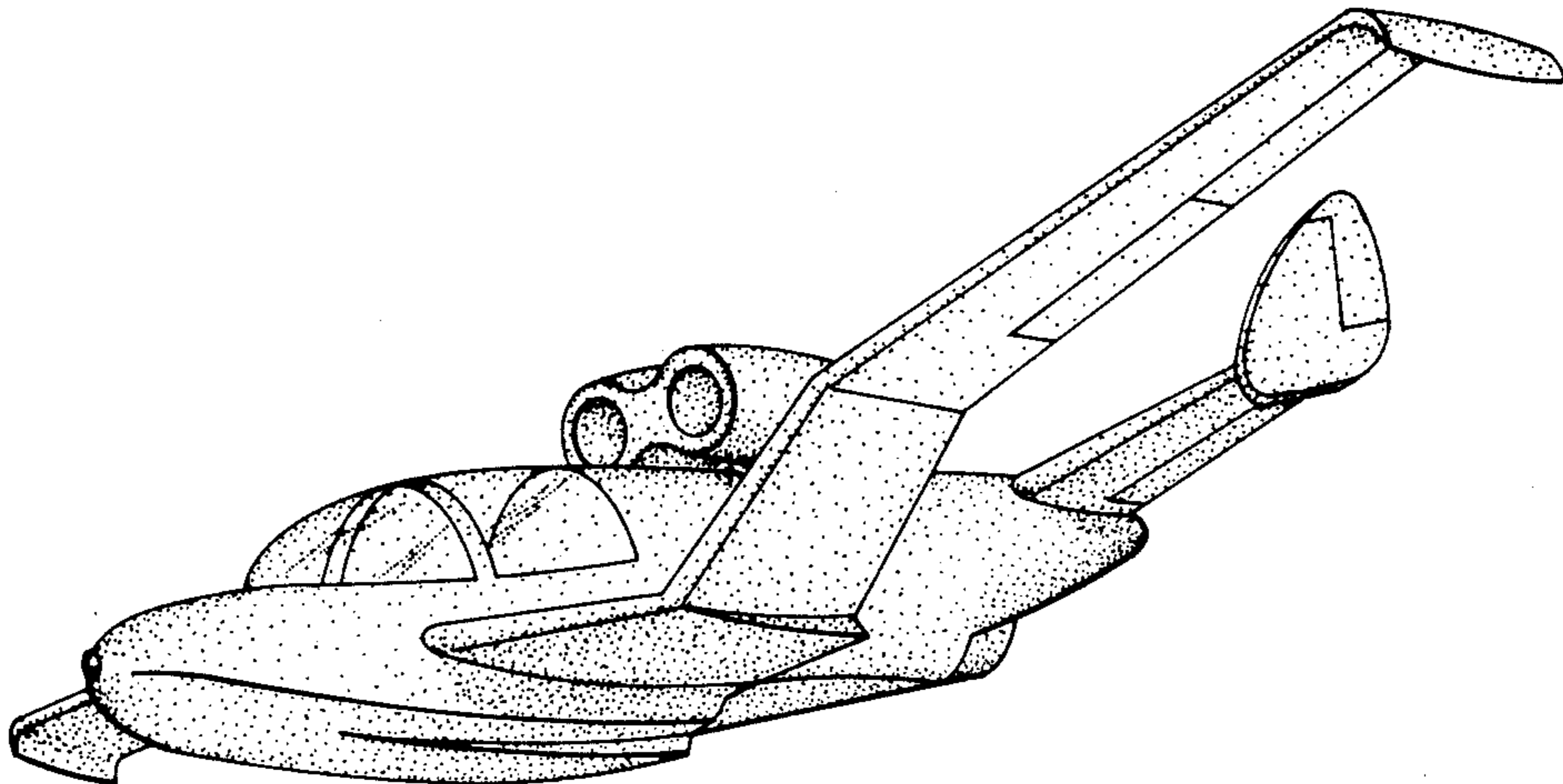

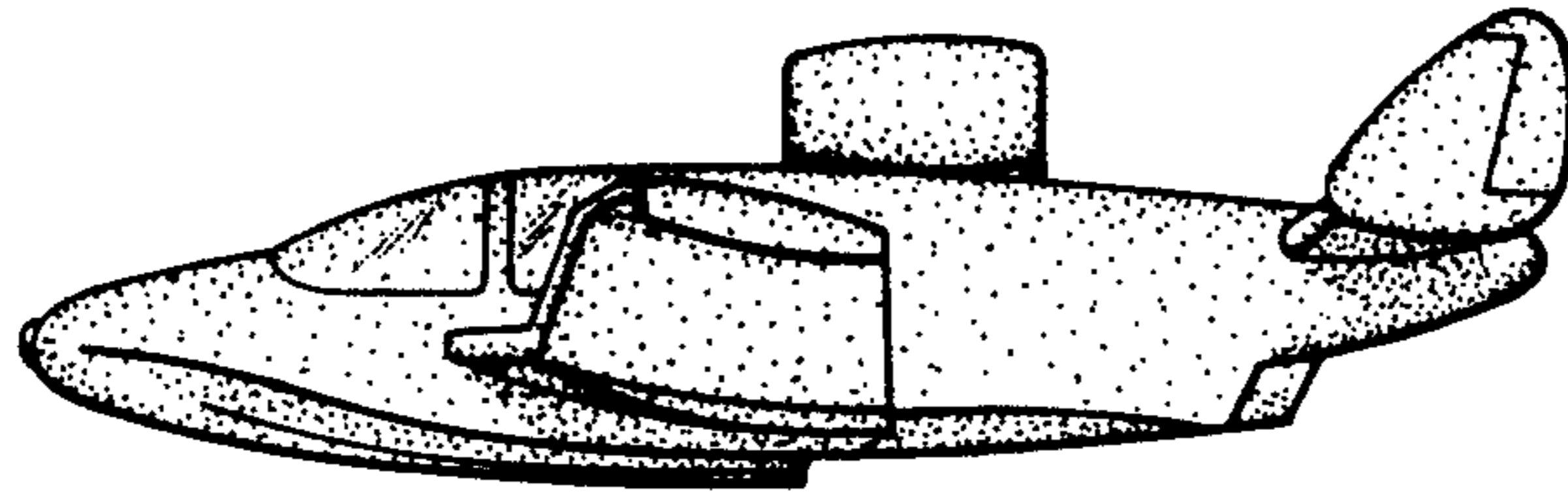

FIG. 1

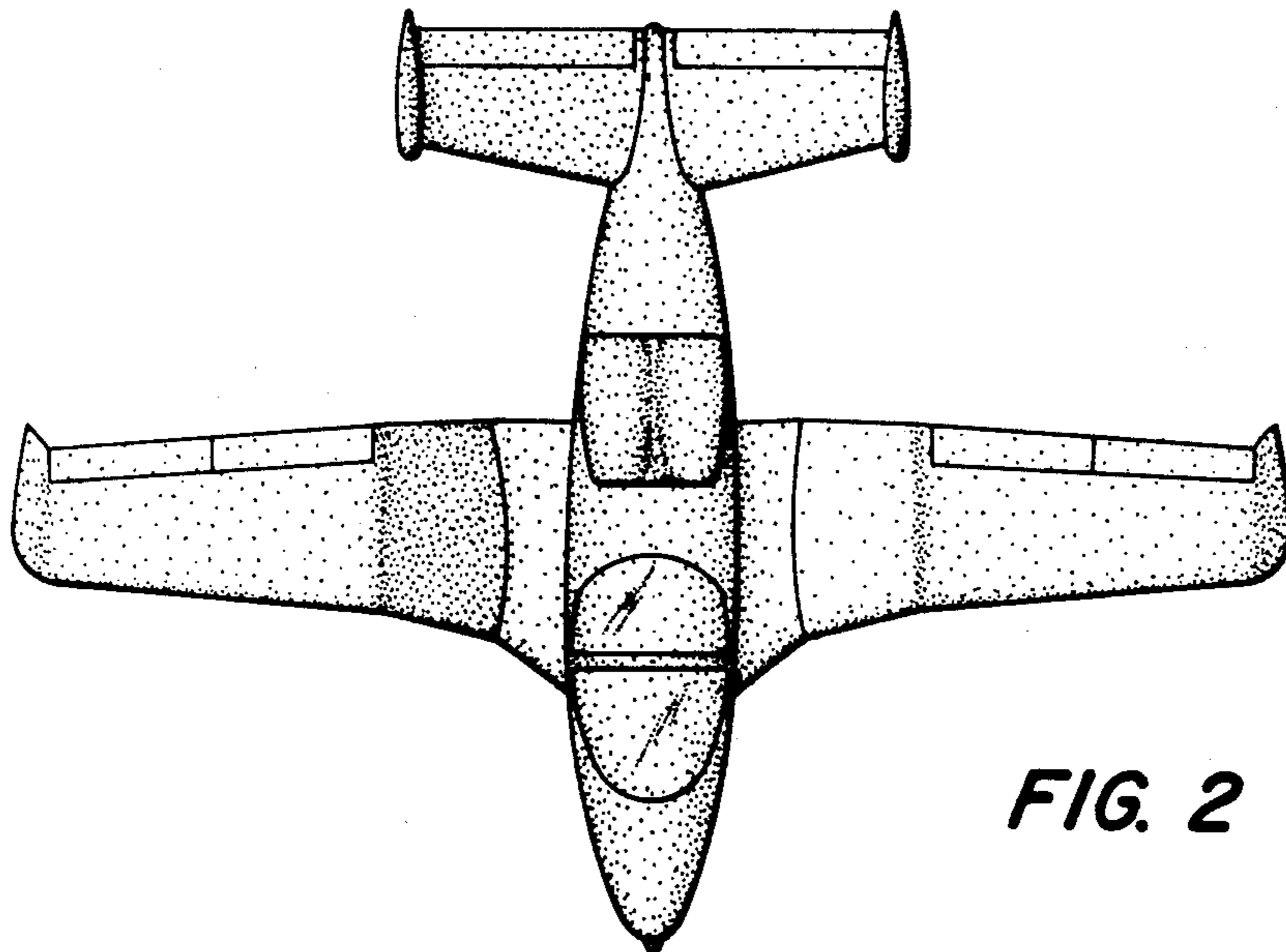

FIG. 2

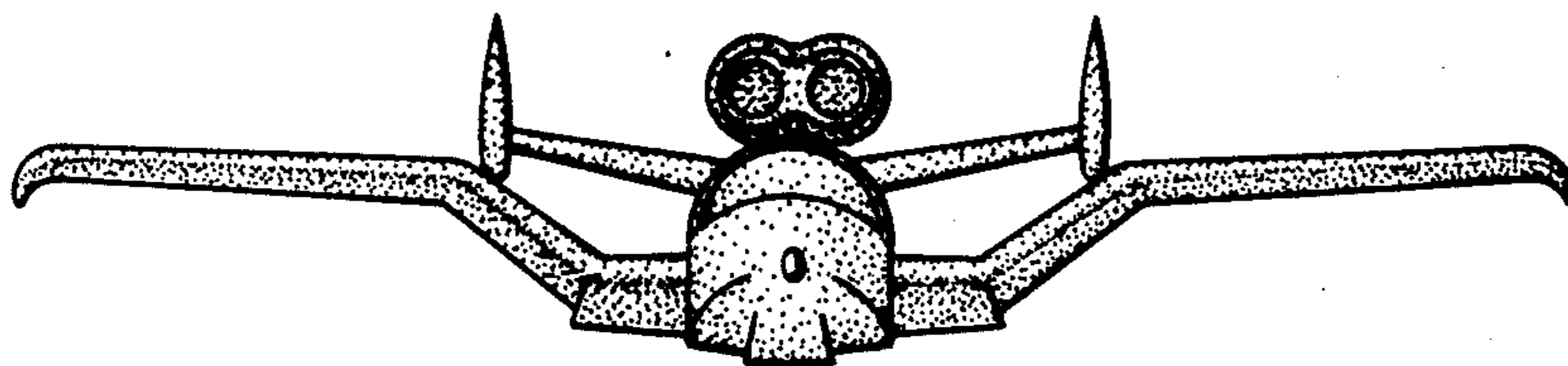

FIG. 3

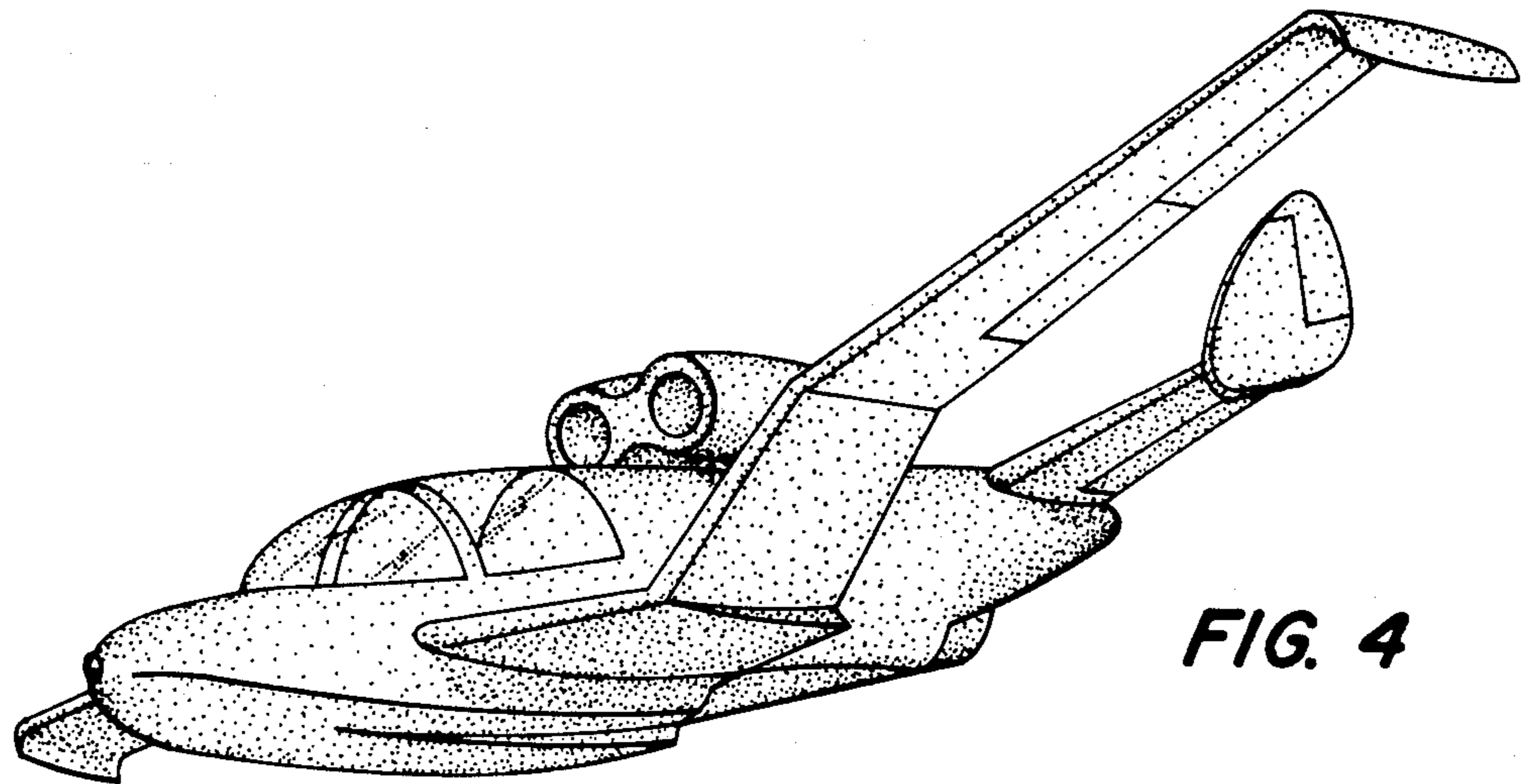

FIG. 4

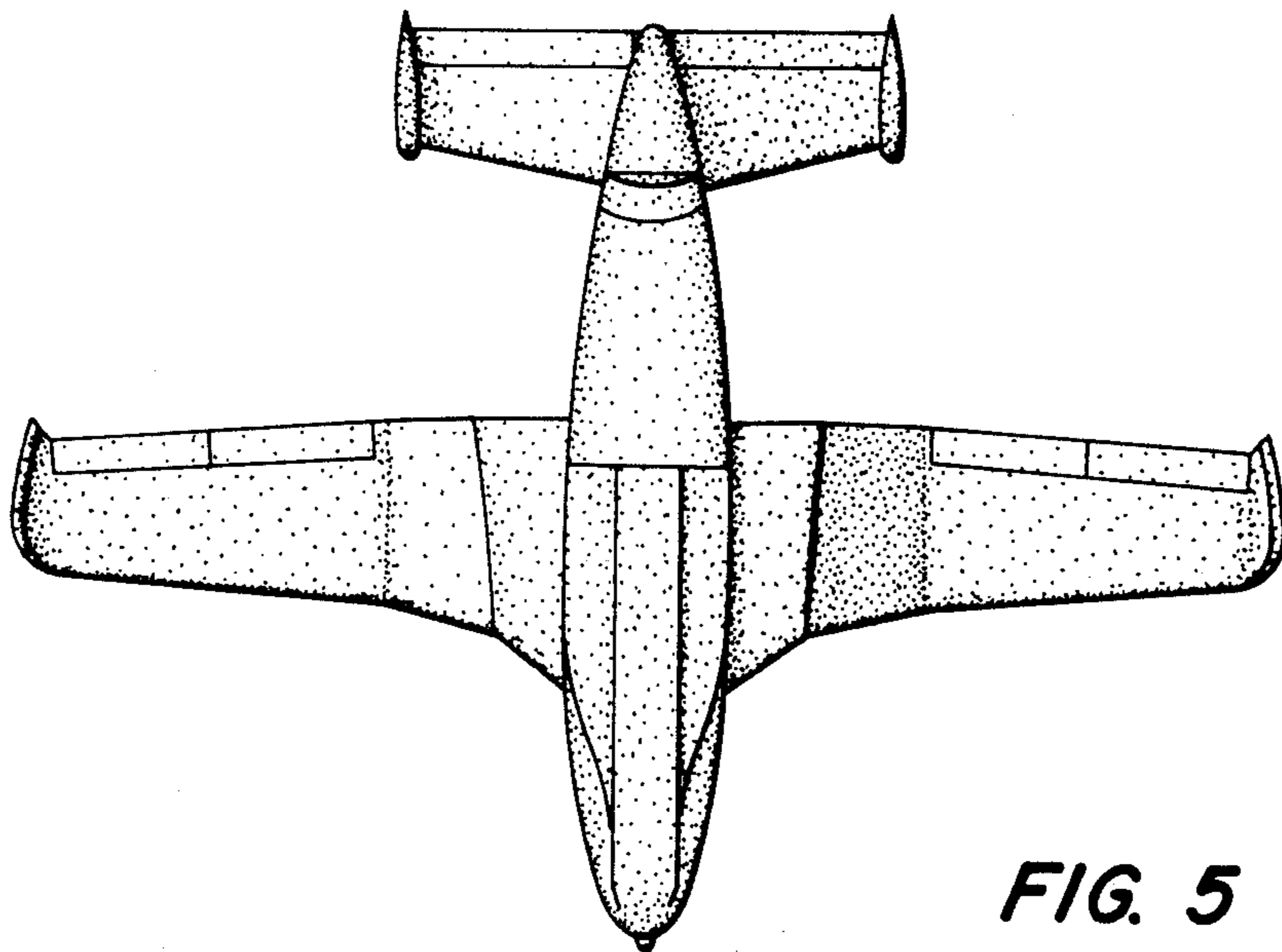

FIG. 5

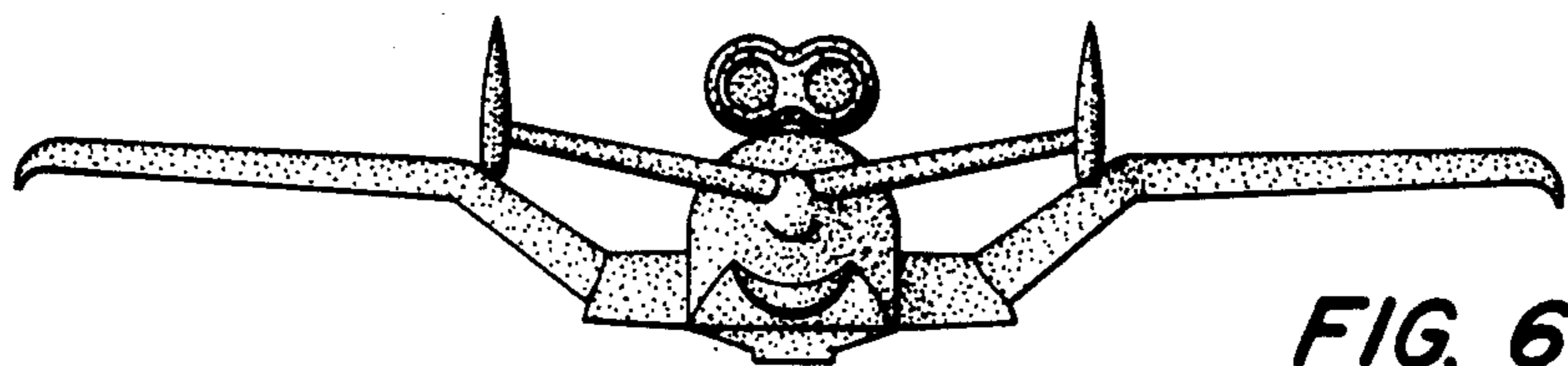

FIG. 6