

[54] COMBINED AIRCRAFT SEAT AND RETRACTABLE HEADREST UNIT OR THE LIKE

[75] Inventor: Walter L. Cook, Seattle, Wash.
[73] Assignee: The Boeing Company, Seattle, Wash.
[**] Term: 14 Years
[21] Appl. No.: 864,567
[22] Filed: Dec. 27, 1977

[51] Int. Cl. D6-01
[52] U.S. Cl. D6/48; D6/37; D6/71; D6/200; D6/63
[58] Field of Search D6/37-39, D6/67-75, 200; 297/384, 385, 389, 391, 396, 403, 410, 445; 108/157

[56] References Cited
U.S. PATENT DOCUMENTS

Table with 4 columns: Patent No., Date, Inventor, and Design No. listing various references such as D. 184,992, D. 197,601, etc.

Primary Examiner—Bruce W. Dunkins
Attorney, Agent, or Firm—Daniel T. Anderson; Bernard A. Donahue

[57] CLAIM

The ornamental design for a combined aircraft seat and

retractable headrest unit or the like, substantially as shown and described.

DESCRIPTION

FIG. 1 is a front perspective view of a combined aircraft seat and retractable headrest unit or the like wherein the headrest unit is shown in retracted position; FIG. 2 is a front elevational view thereof; FIG. 3 is a left-side elevational view thereof, the right side being a mirror image thereof; FIG. 4 is a top, plan view thereof, the bottom being essentially plain; FIG. 5 is a rear elevational view thereof; FIG. 6 is a front perspective view of the seat shown in FIG. 1 but wherein the retractable headrest unit is shown in fully extended position and a seat belt arrangement is shown therein in broken lines for illustrative purposes only. FIG. 7 is a front elevational view thereof; FIG. 8 is a left-side elevational view thereof, the right side being a mirror image thereof; FIG. 9 is a top plan view thereof, the bottom being essentially plain; FIG. 10 is a rear elevational view thereof; FIG. 11 is a front perspective view of the FIG. 1 design shown in the form of a loveseat; FIG. 12 is a front perspective view thereof with the retractable headrest unit shown in fully extended position; FIG. 13 is a front perspective view of the design of FIG. 1 but shown in the form of a divan; and FIG. 14 is a front perspective view thereof wherein the retractable headrest unit is shown in fully extended position. The seat of FIGS. 13 and 14 are shown broken away to indicate indeterminate length.

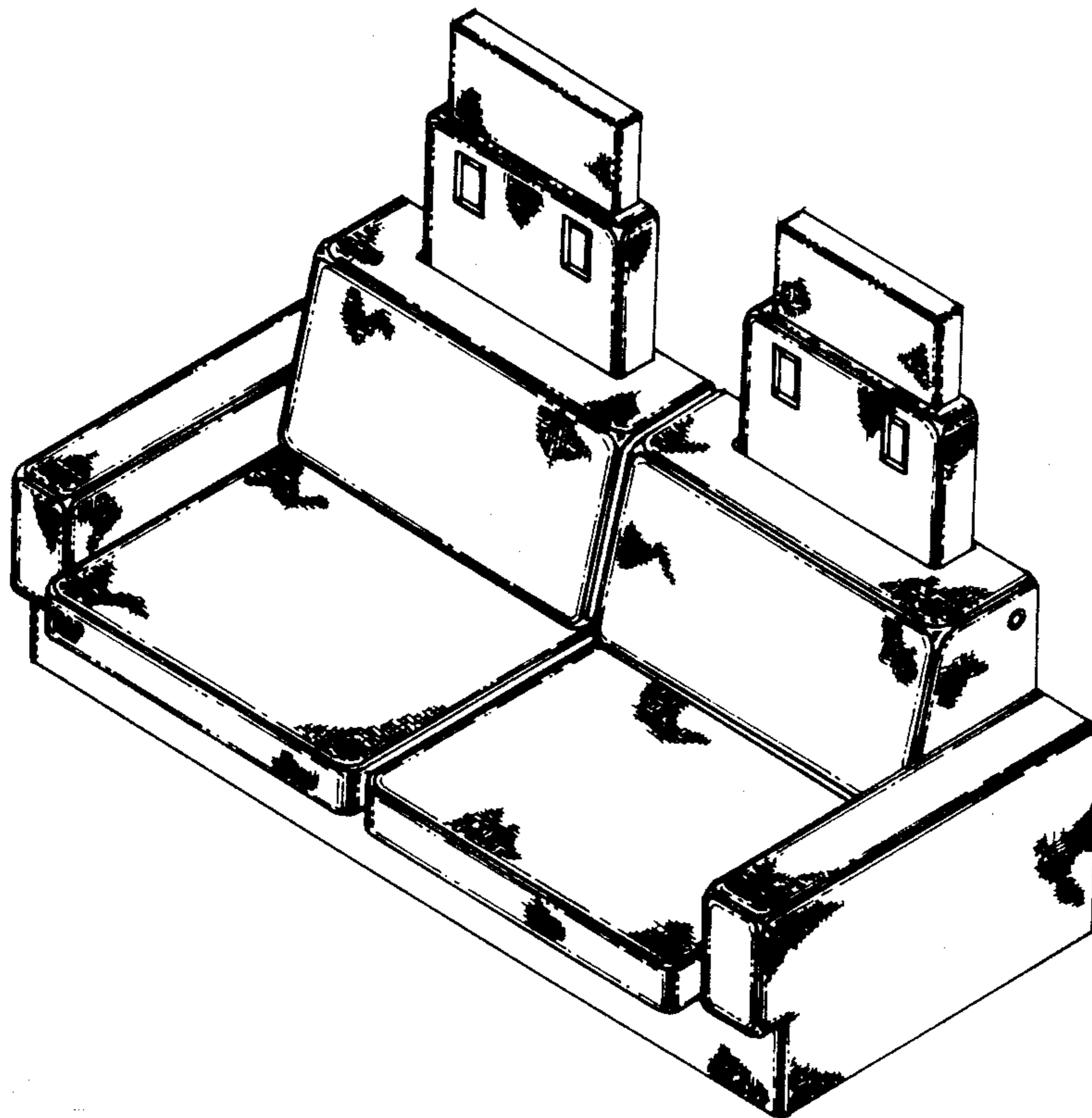

Fig. 1

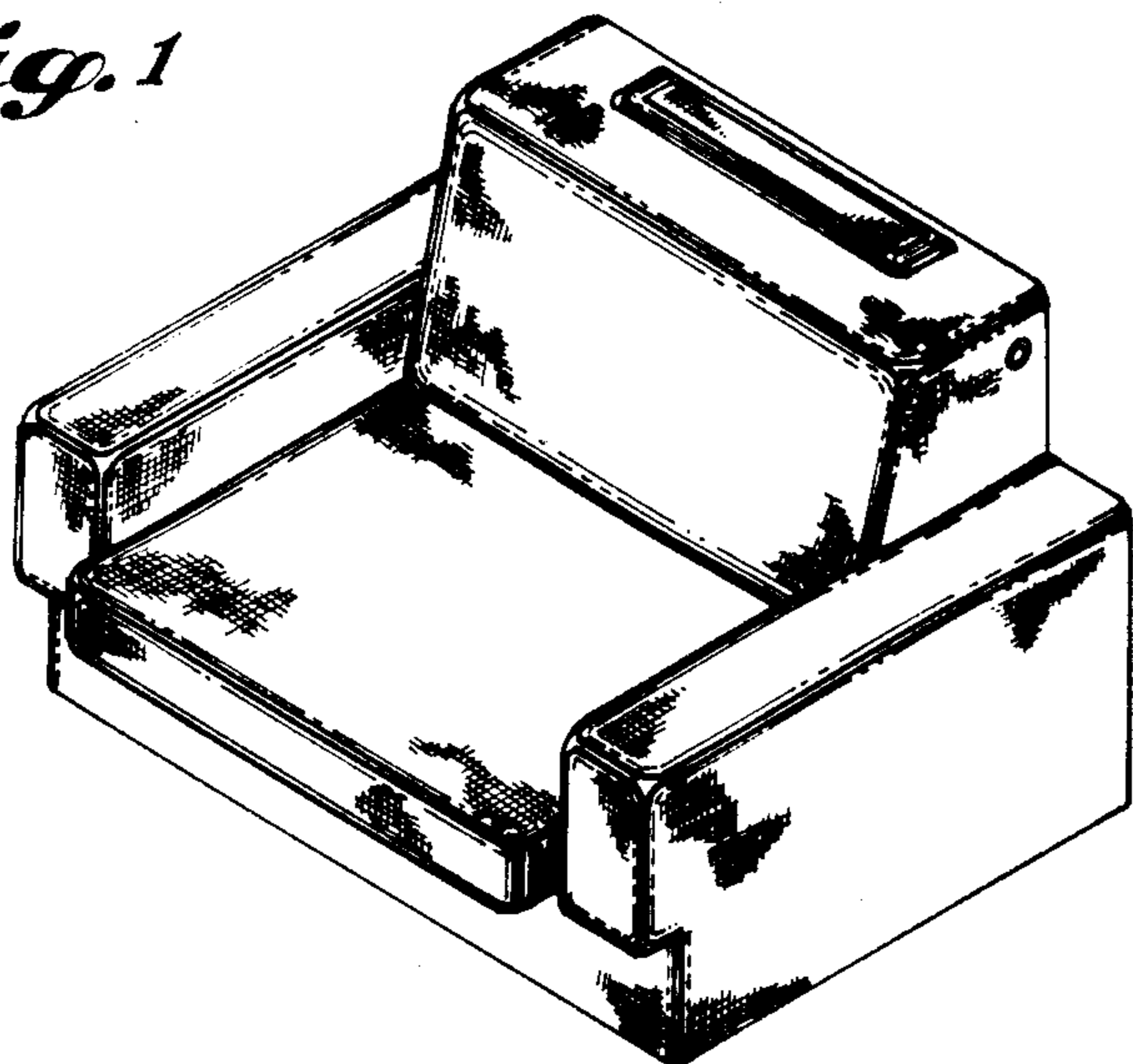

Fig. 2

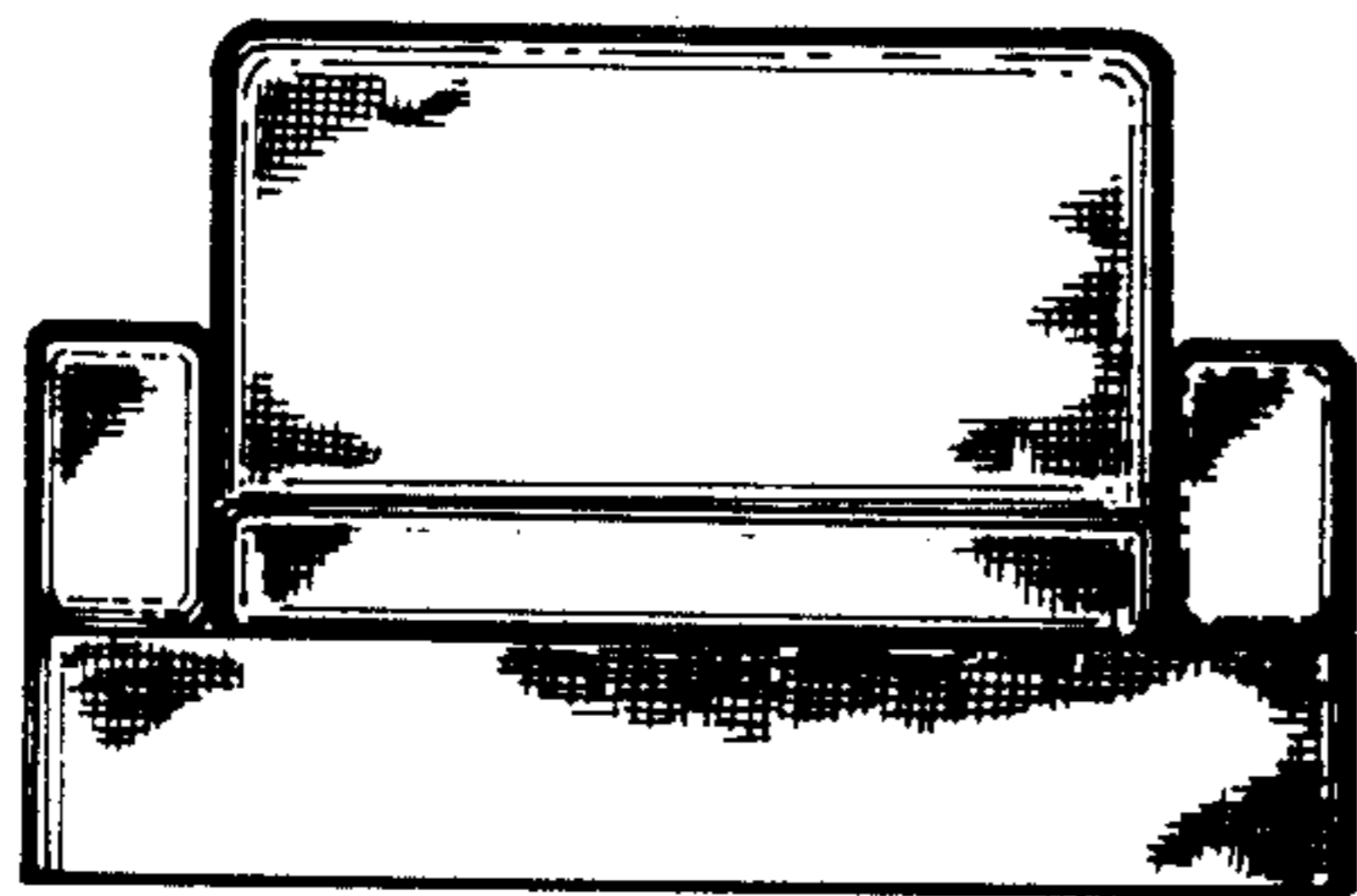

Fig. 3

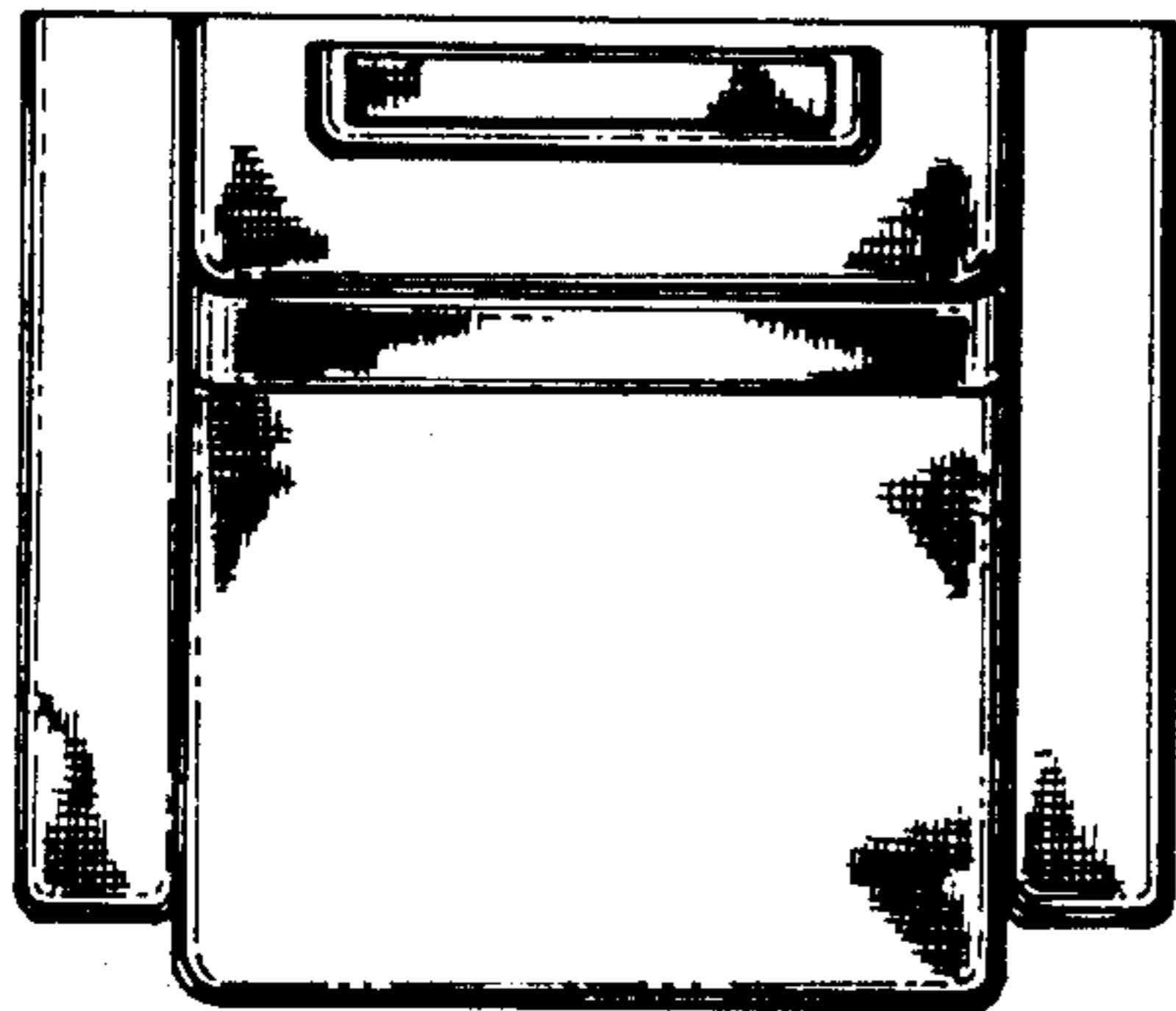
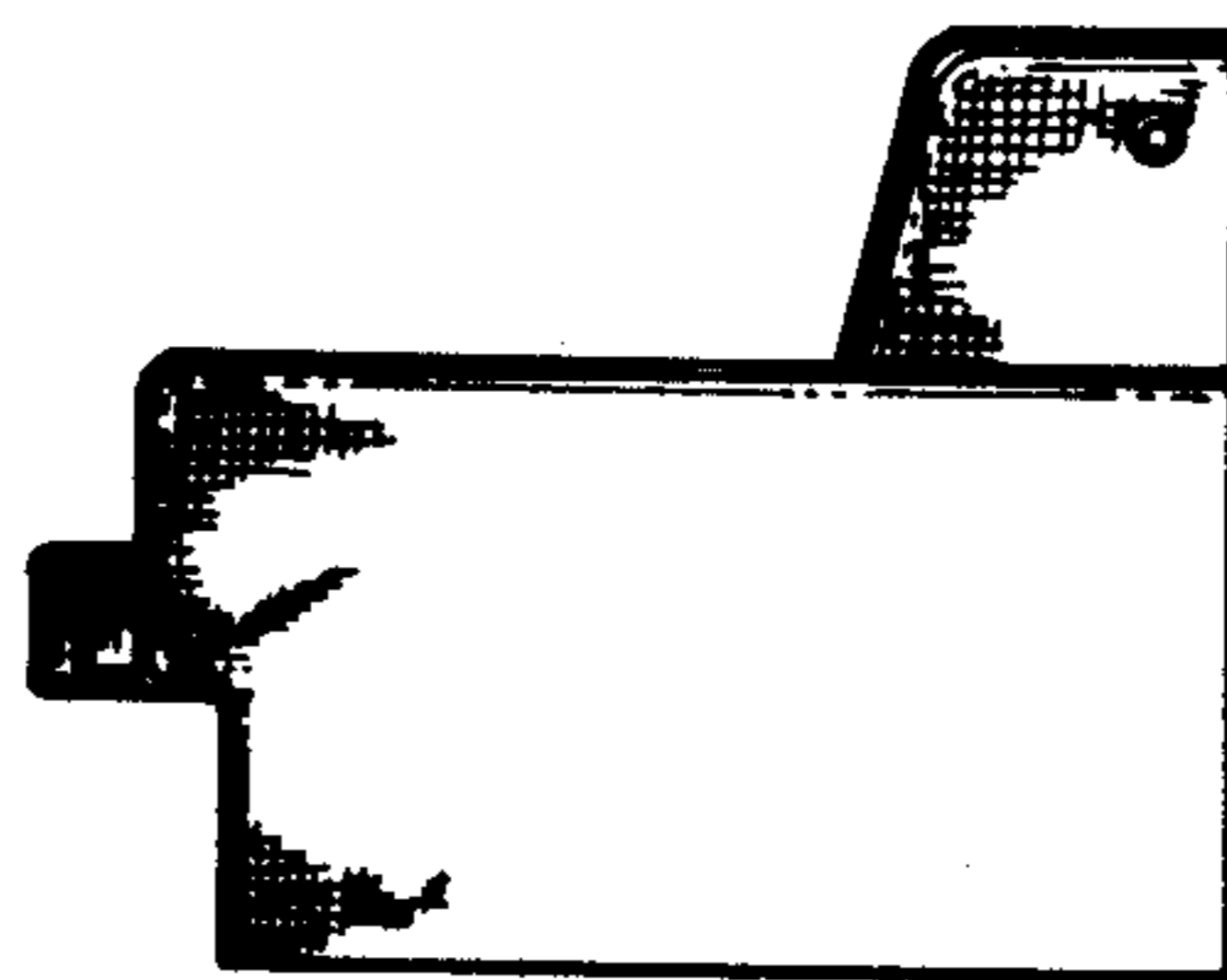

Fig. 4

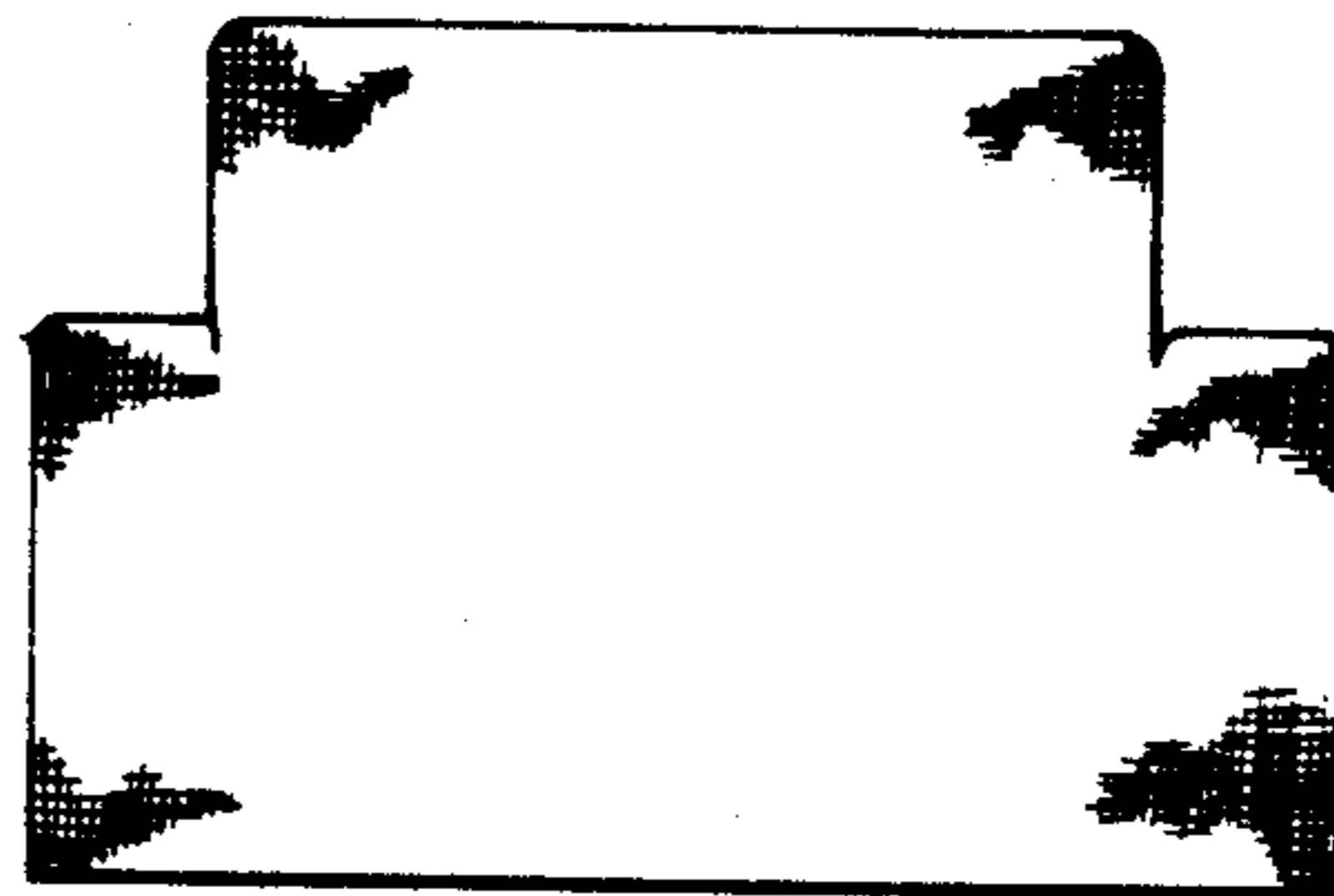

Fig. 5

Fig. 6

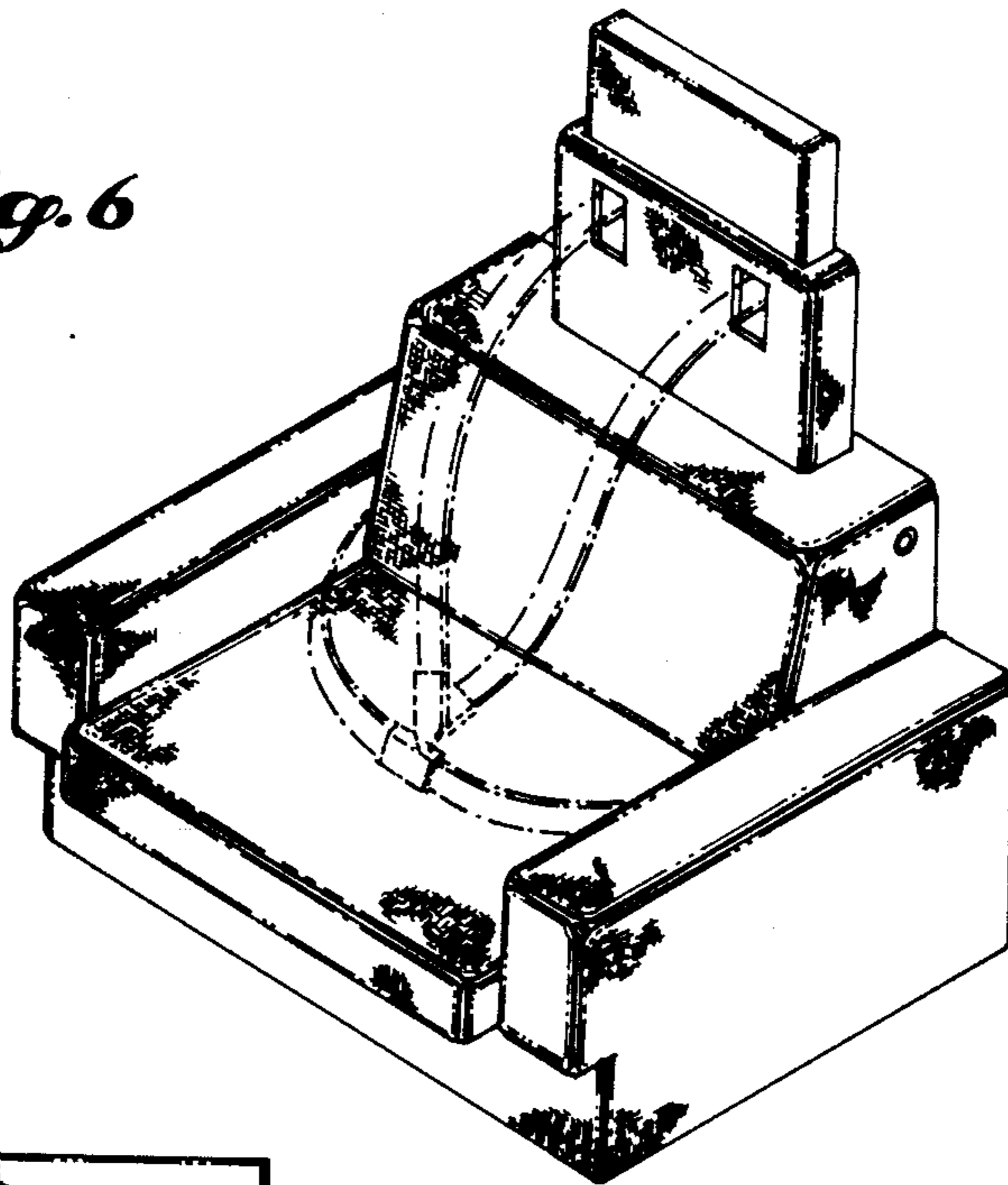

Fig. 7

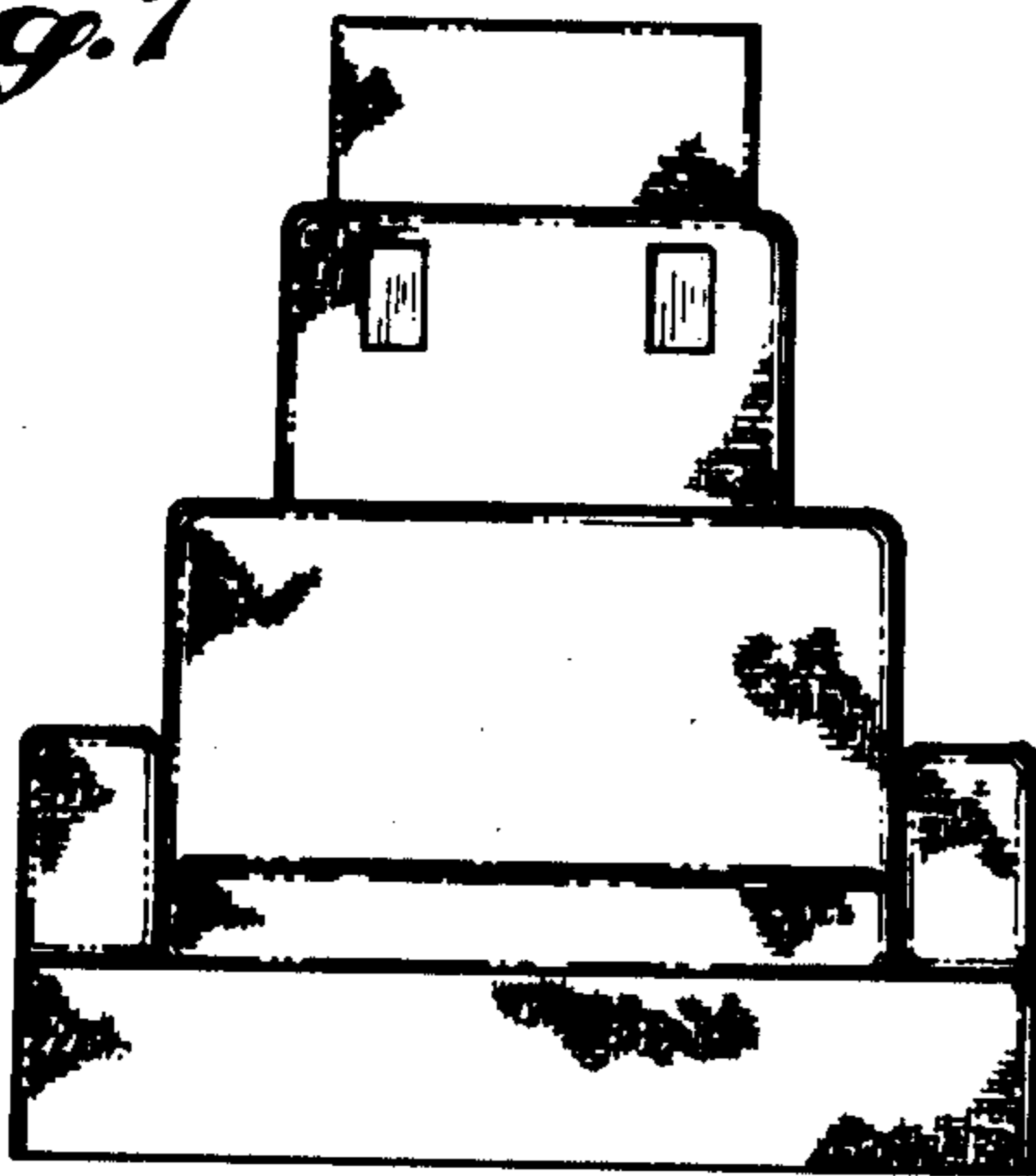

Fig. 8

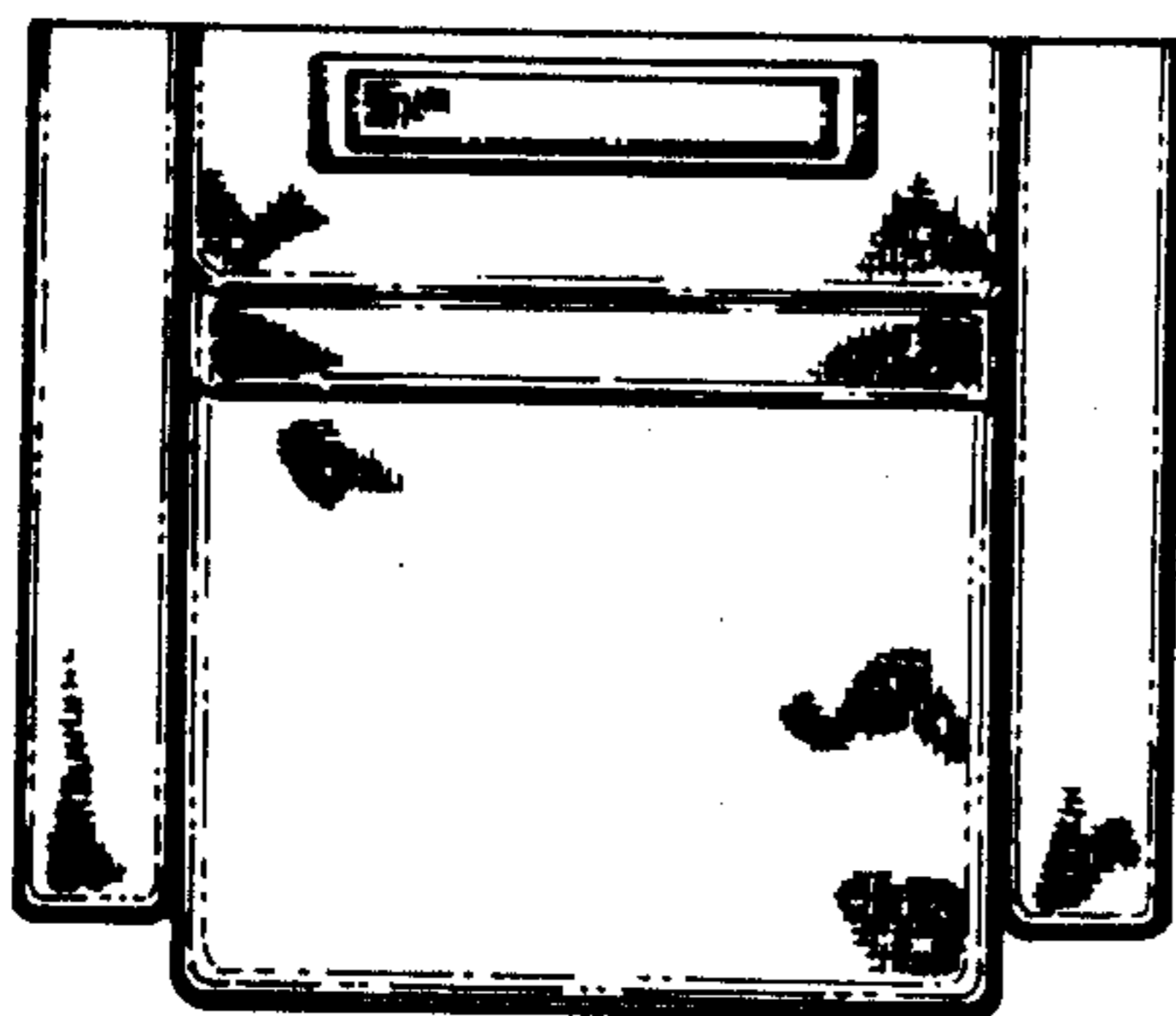
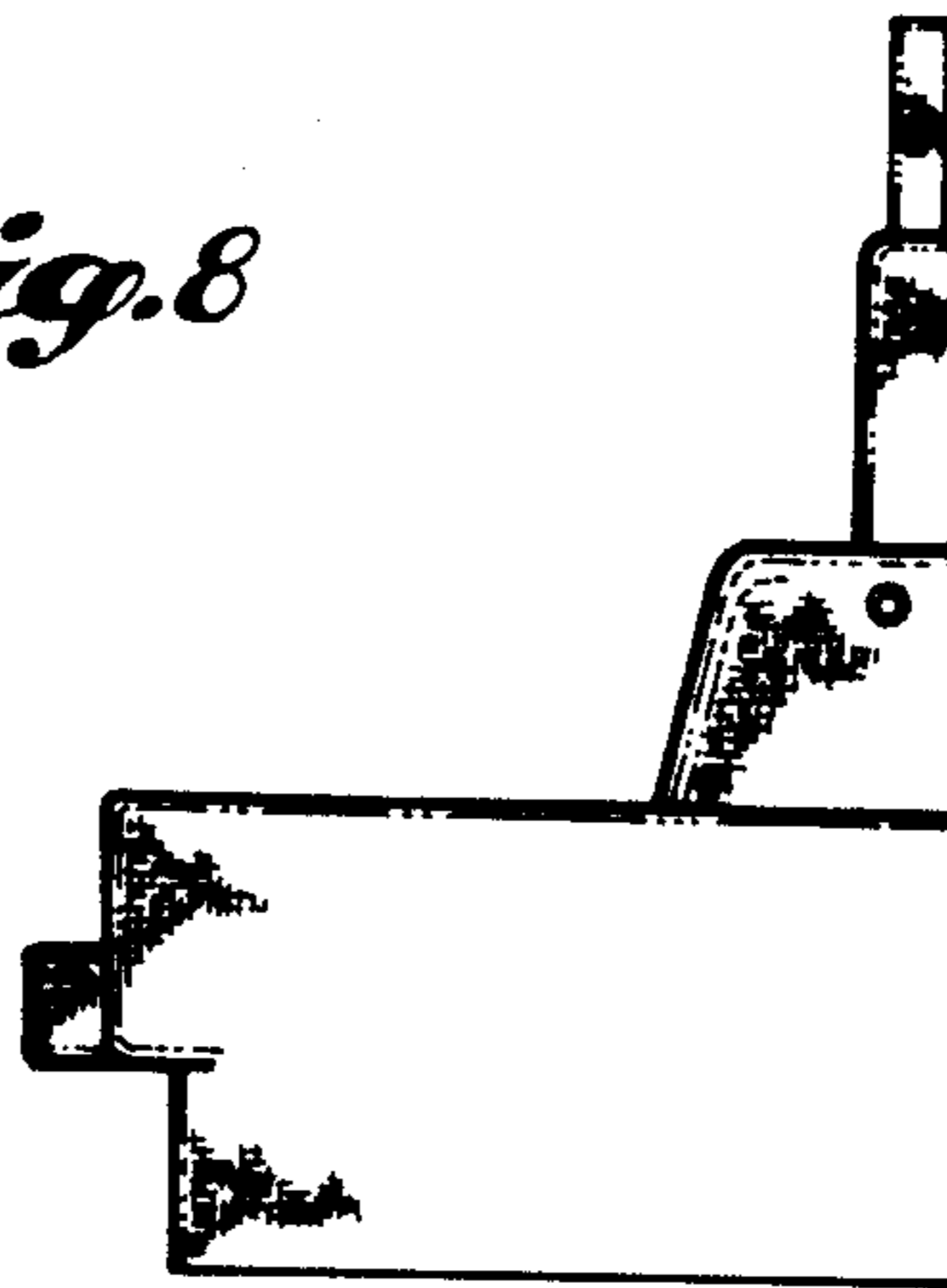

Fig. 9

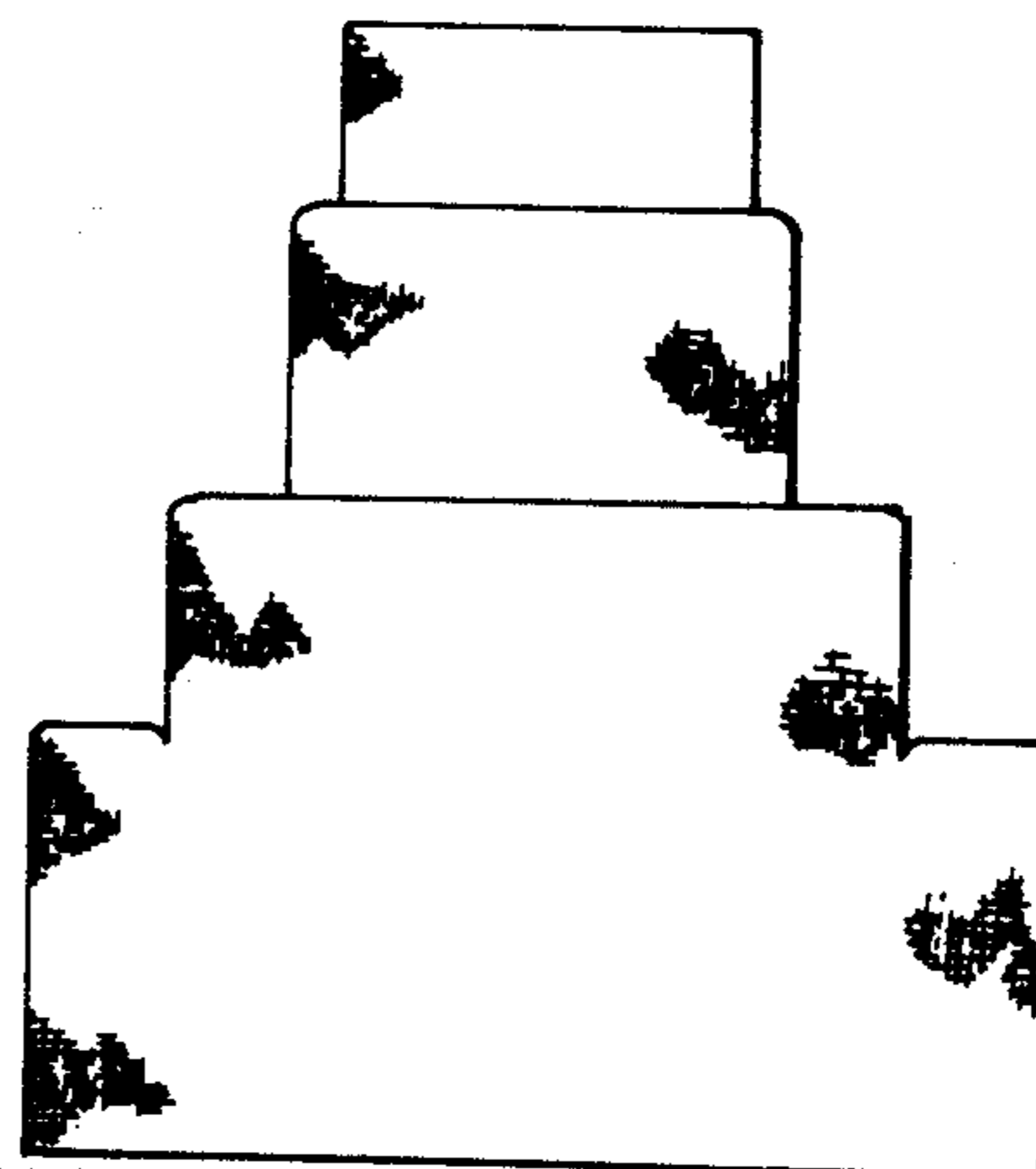

Fig. 10

Fig. 11

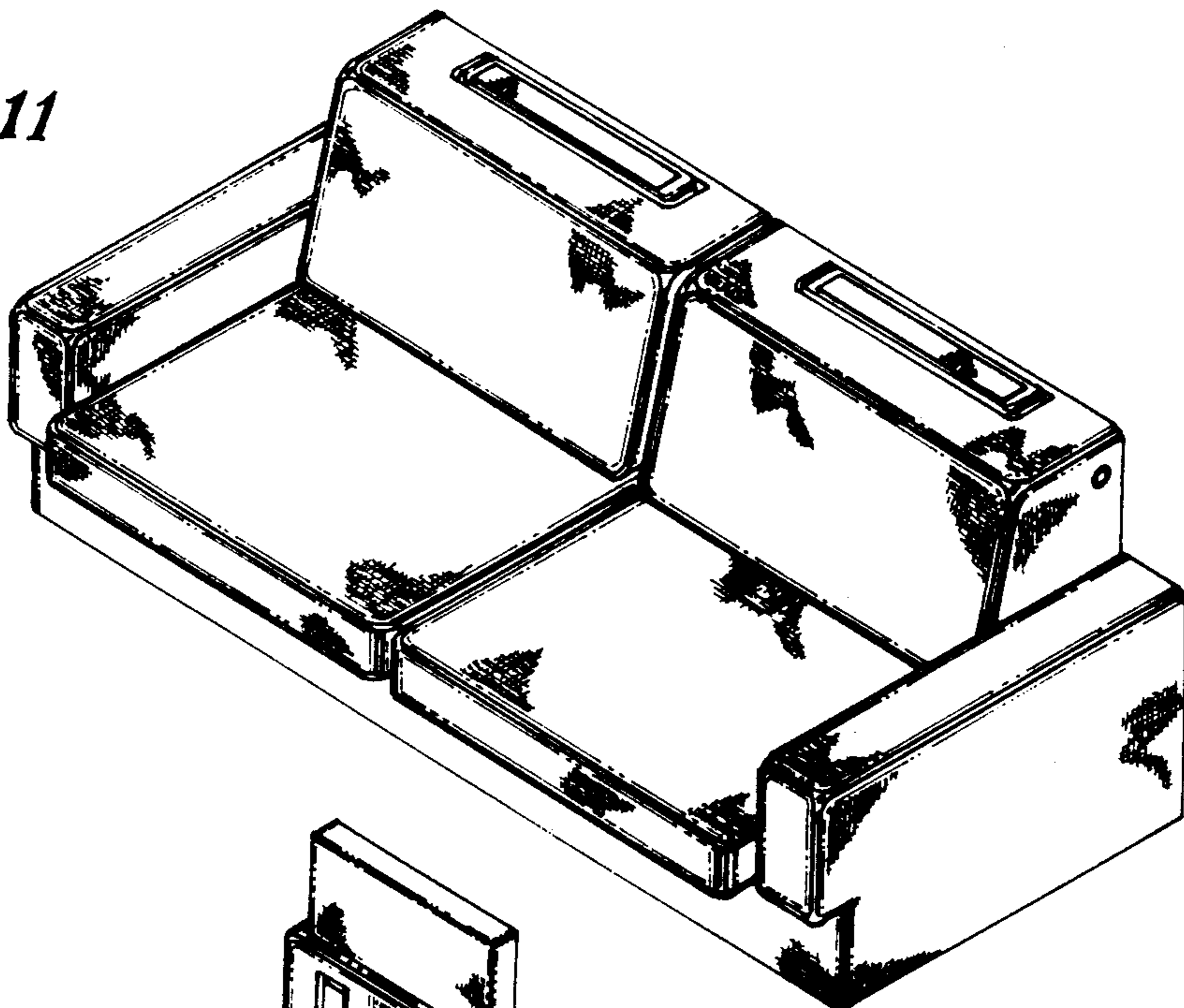

Fig. 12

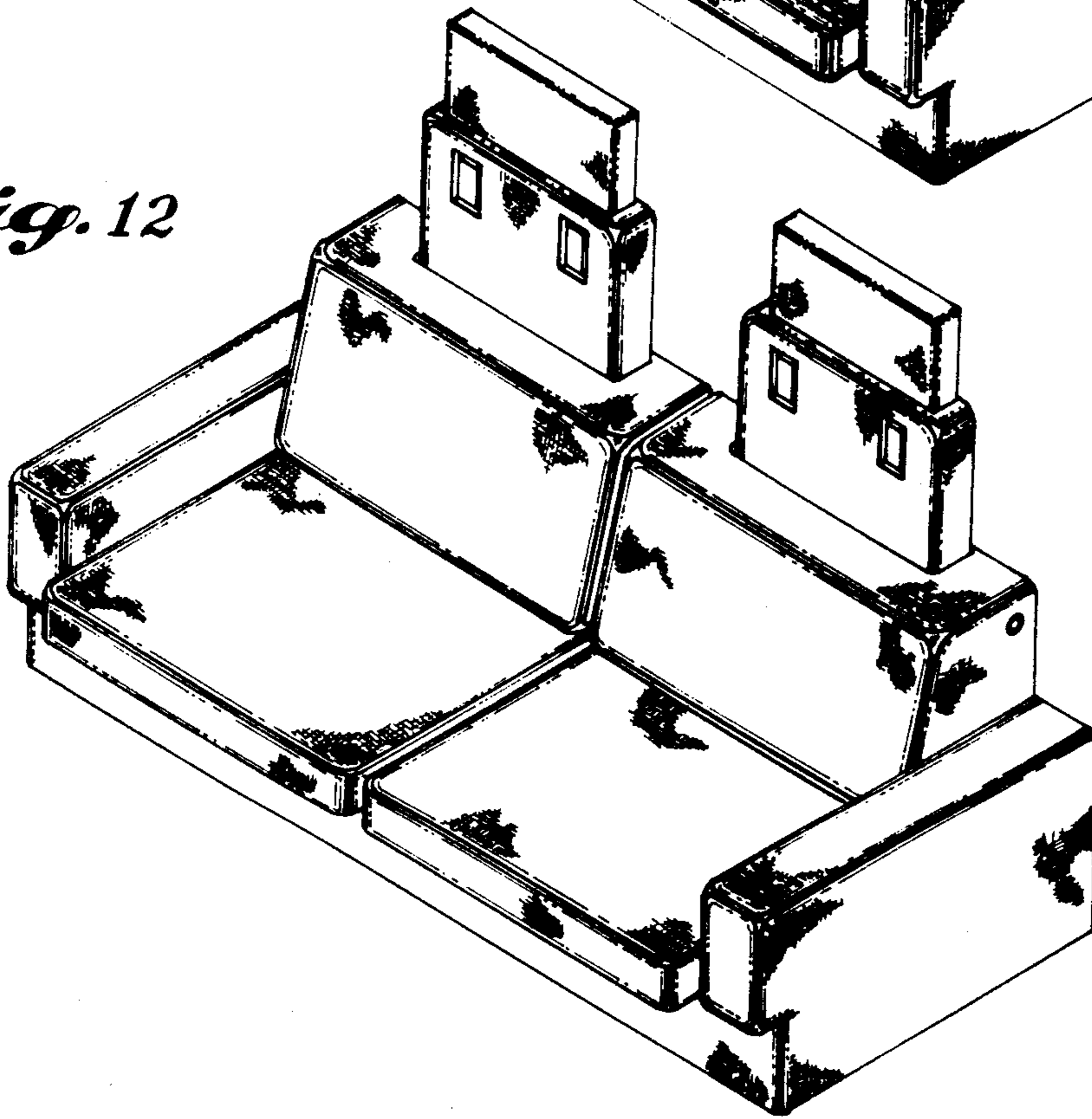

Fig. 13

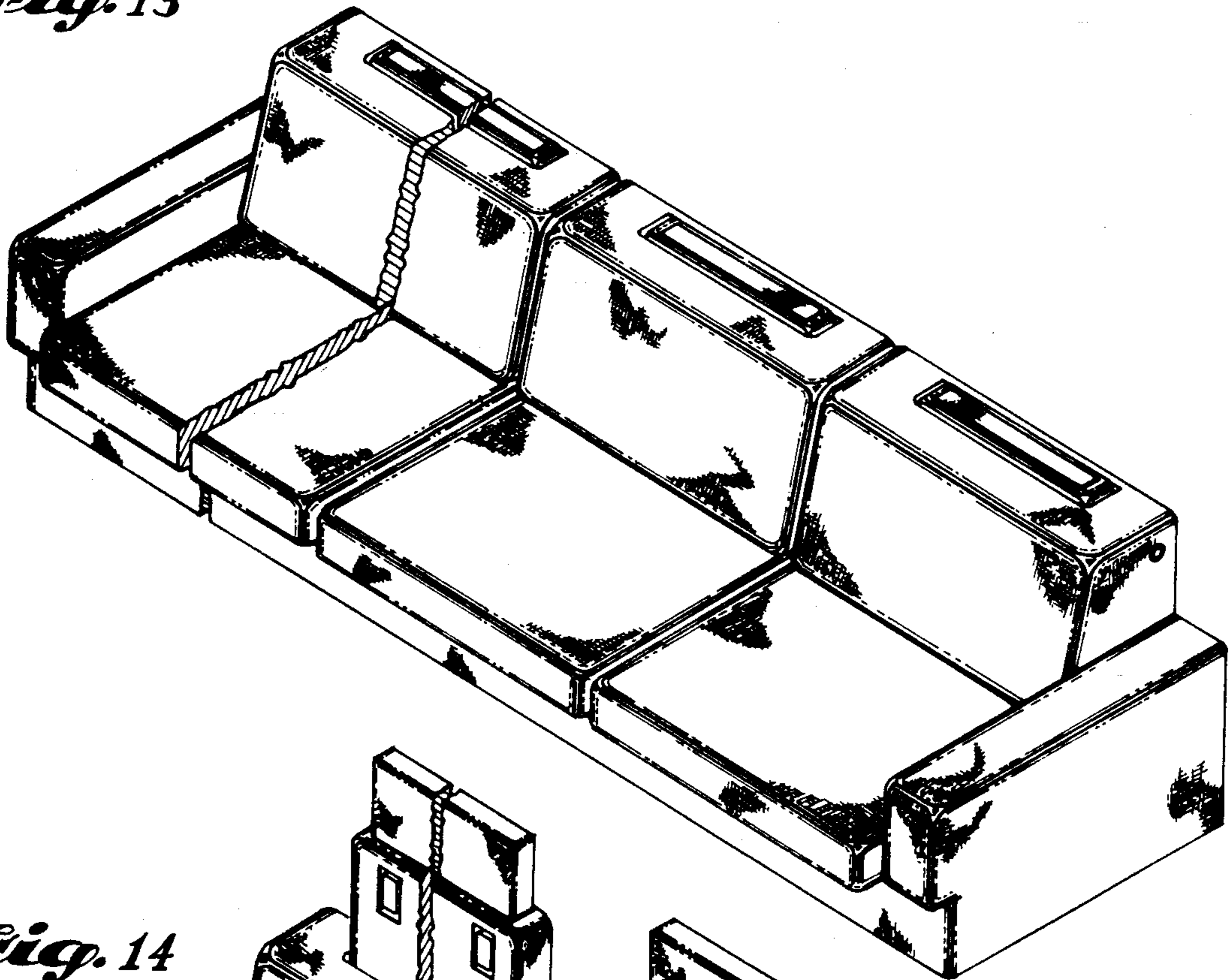

Fig. 14

