

[54] BATTERY OPERATED LANTERN

[75] Inventor: Kittson Mann, Kowloon, Hong Kong

[73] Assignee: Chung Mei Metal and Plastic Factory Ltd., Kowloon, Hong Kong

[**] Term: 14 Years

[21] Appl. No.: 907,264

[22] Filed: May 18, 1978

[30] Foreign Application Priority Data

Jan. 16, 1978 [GB] United Kingdom 982965/78

[51] Int. Cl. D26-02

[52] U.S. Cl. D26/44

[58] Field of Search D48/24 R; 362/157, 183, 362/189, 190, 194, 195, 196, 197, 198, 199, 200, 201, 202, 203, 204, 205

[56] References Cited

U.S. PATENT DOCUMENTS

D. 190,520 6/1961 Graubner D48/24 R
3,015,719 1/1962 Kirkman 362/194 X

Primary Examiner—Susan J. Lucas
Attorney, Agent, or Firm—William W. Haefliger

[57] CLAIM

The ornamental design for a battery operated lantern, as shown and described.

DESCRIPTION

FIG. 1 is a side elevational view of the battery operated lantern showing my new design;

FIG. 2 is an underneath plan view of the battery operated lantern;

FIG. 3 is a front elevational view of the battery operated lantern;

FIG. 4 is a rear elevational view of the battery operated lantern; and

FIG. 5 is a top plan view of the battery operated lantern.

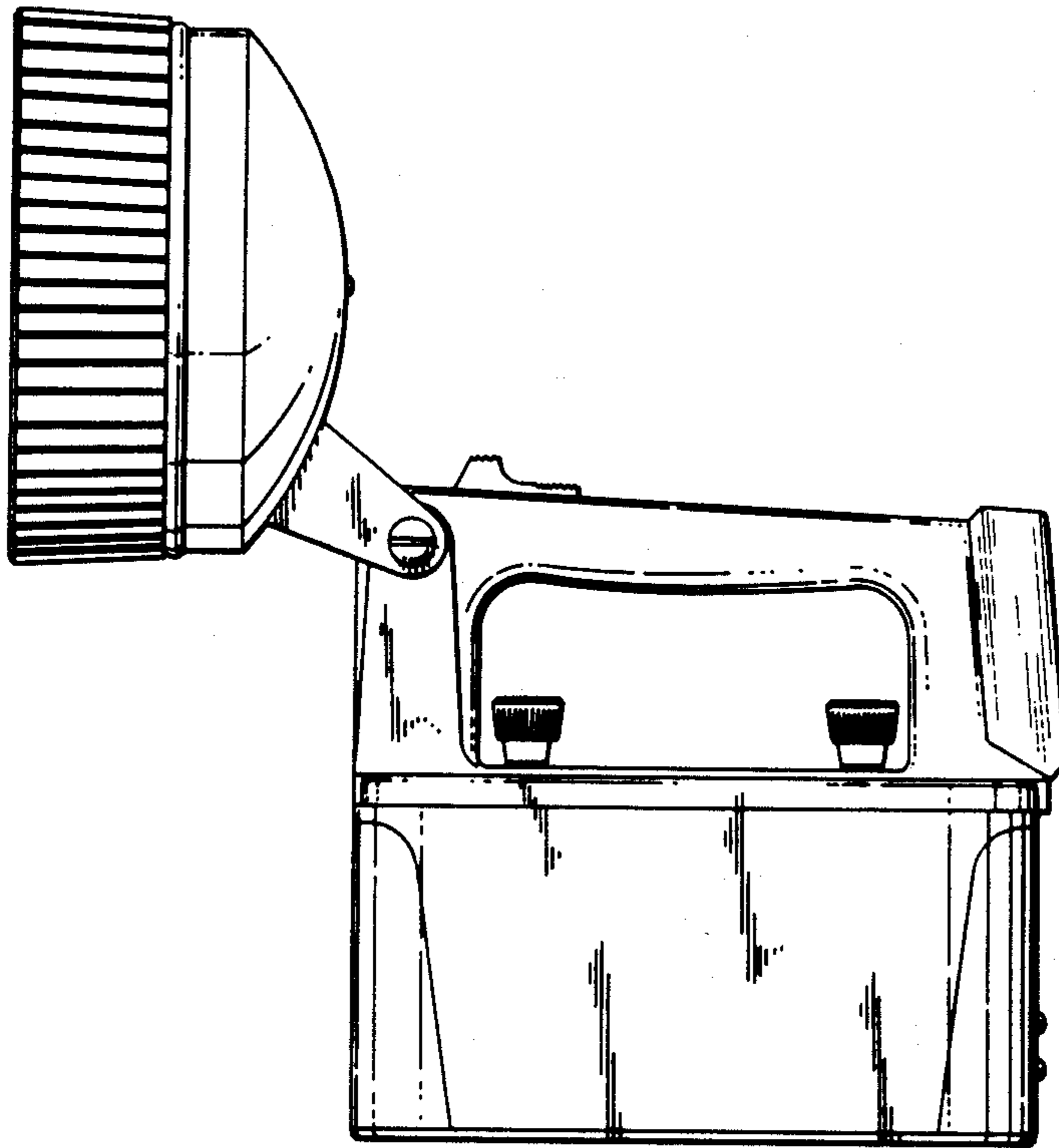

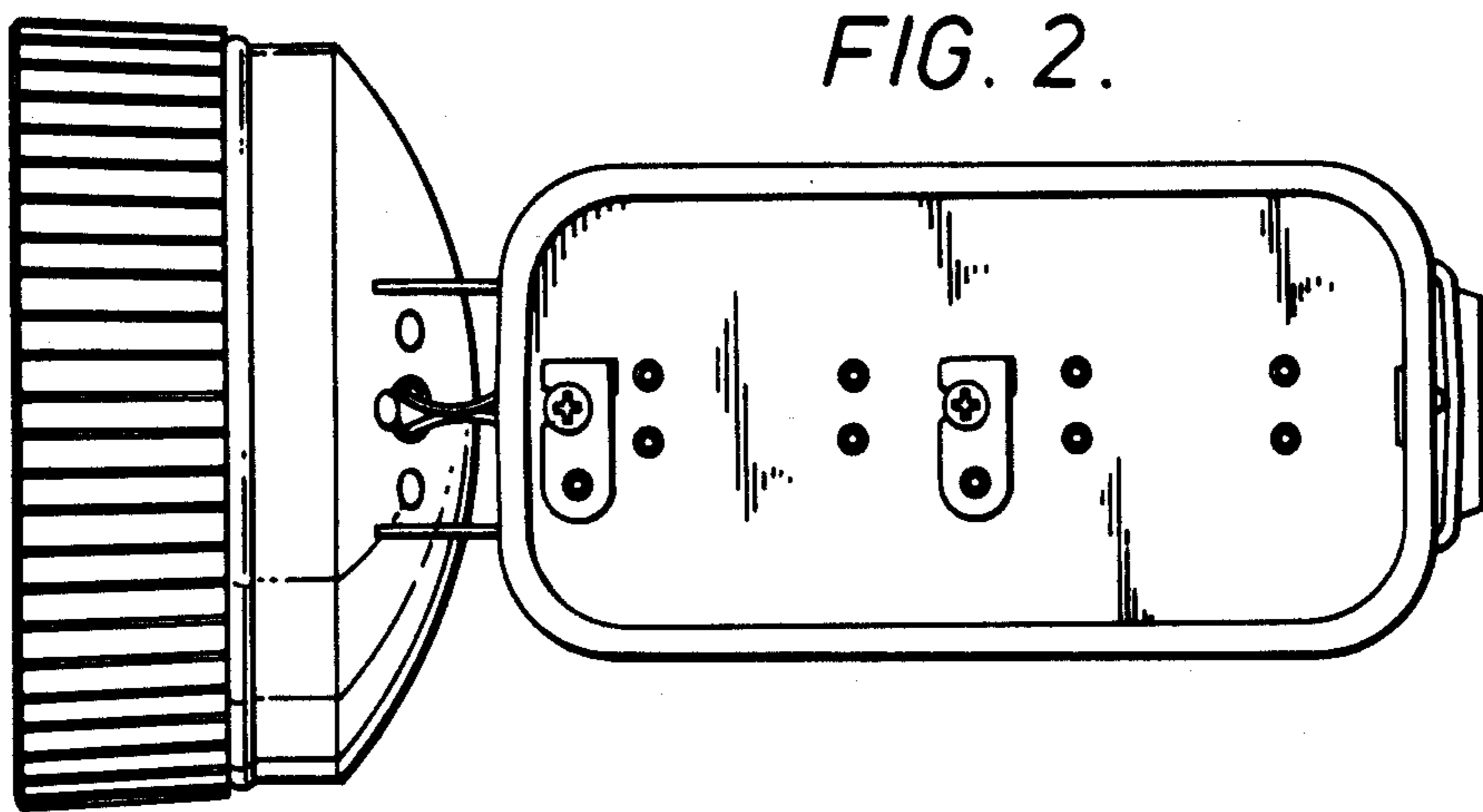
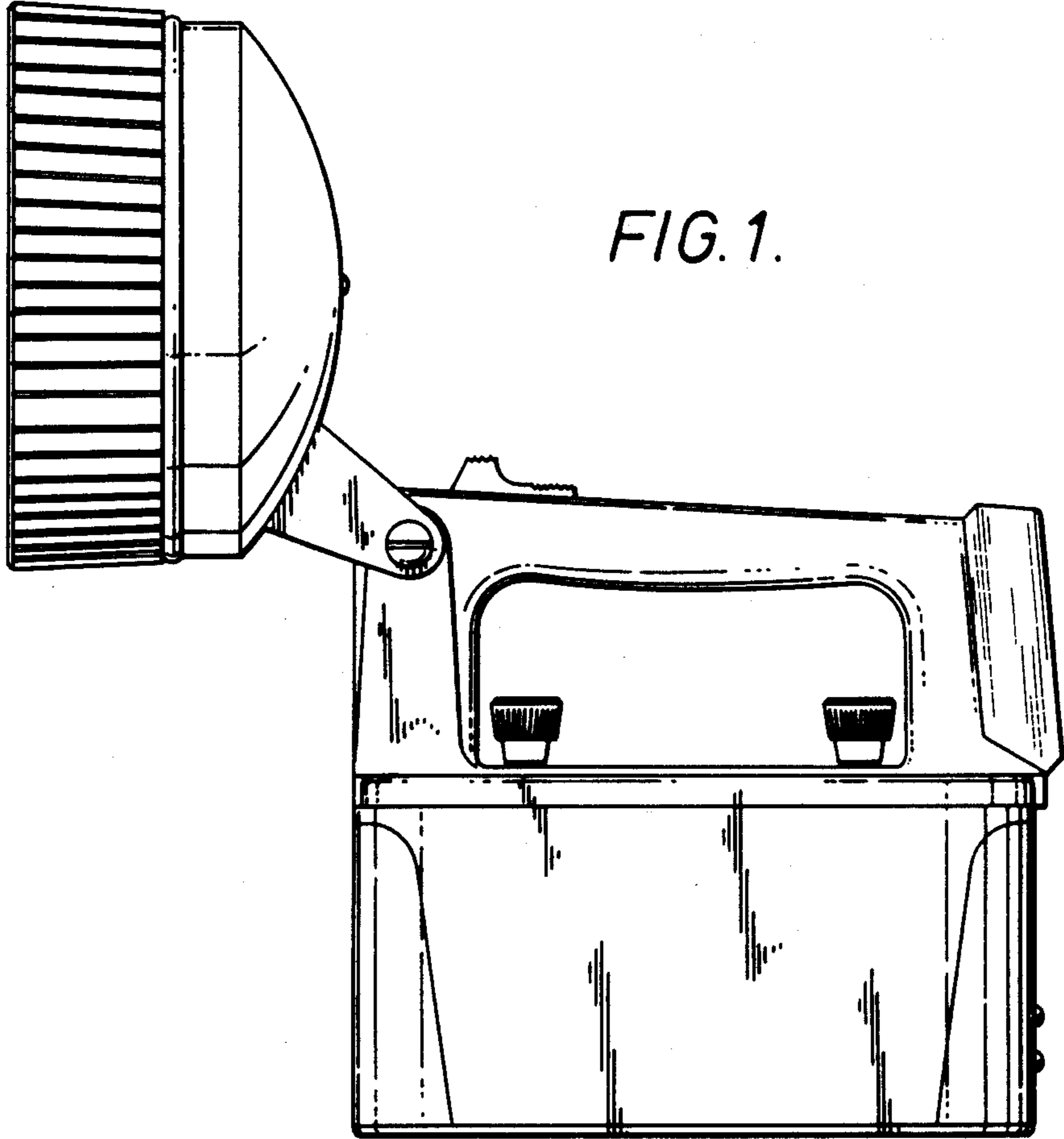

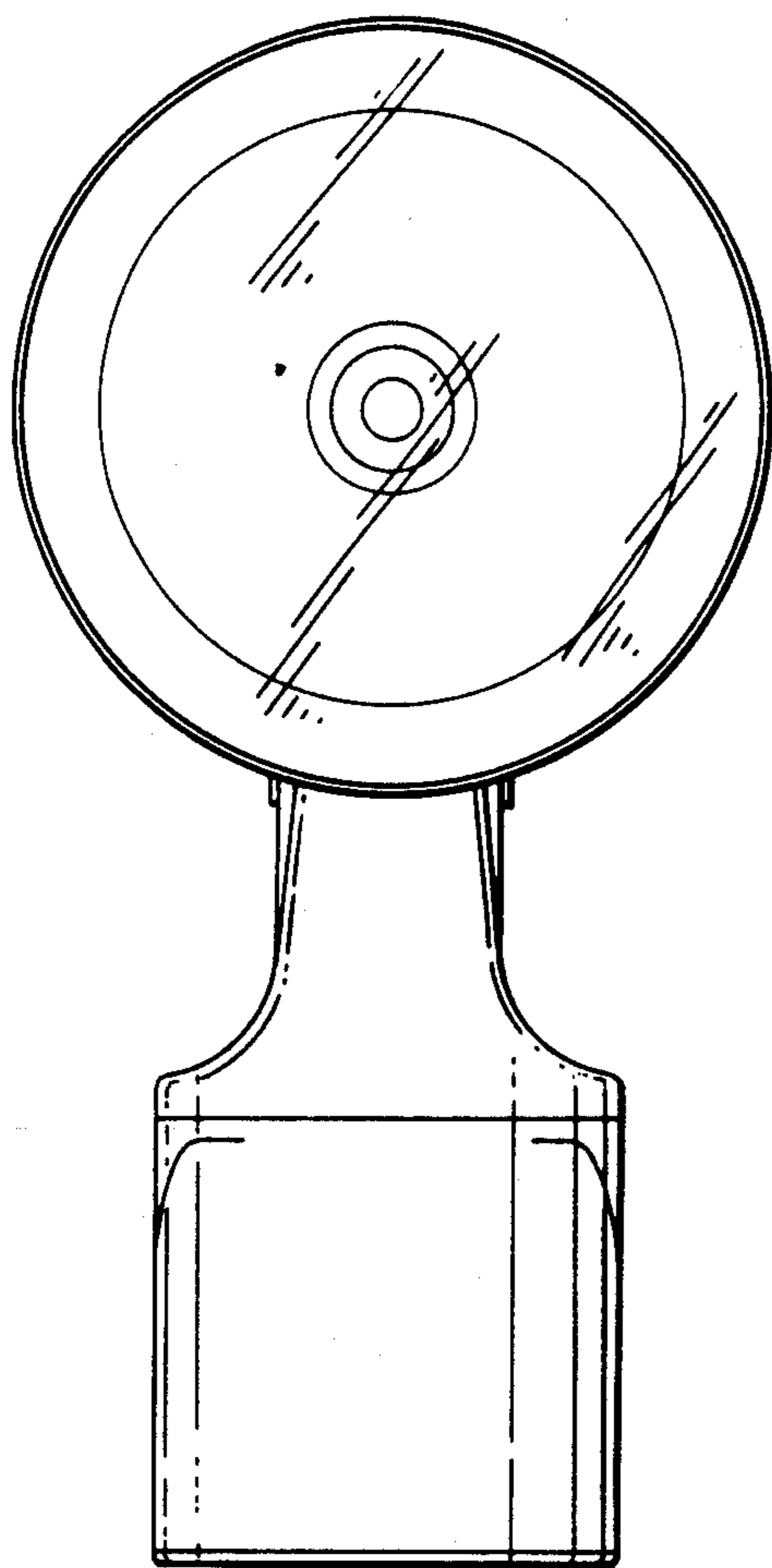

FIG. 3.

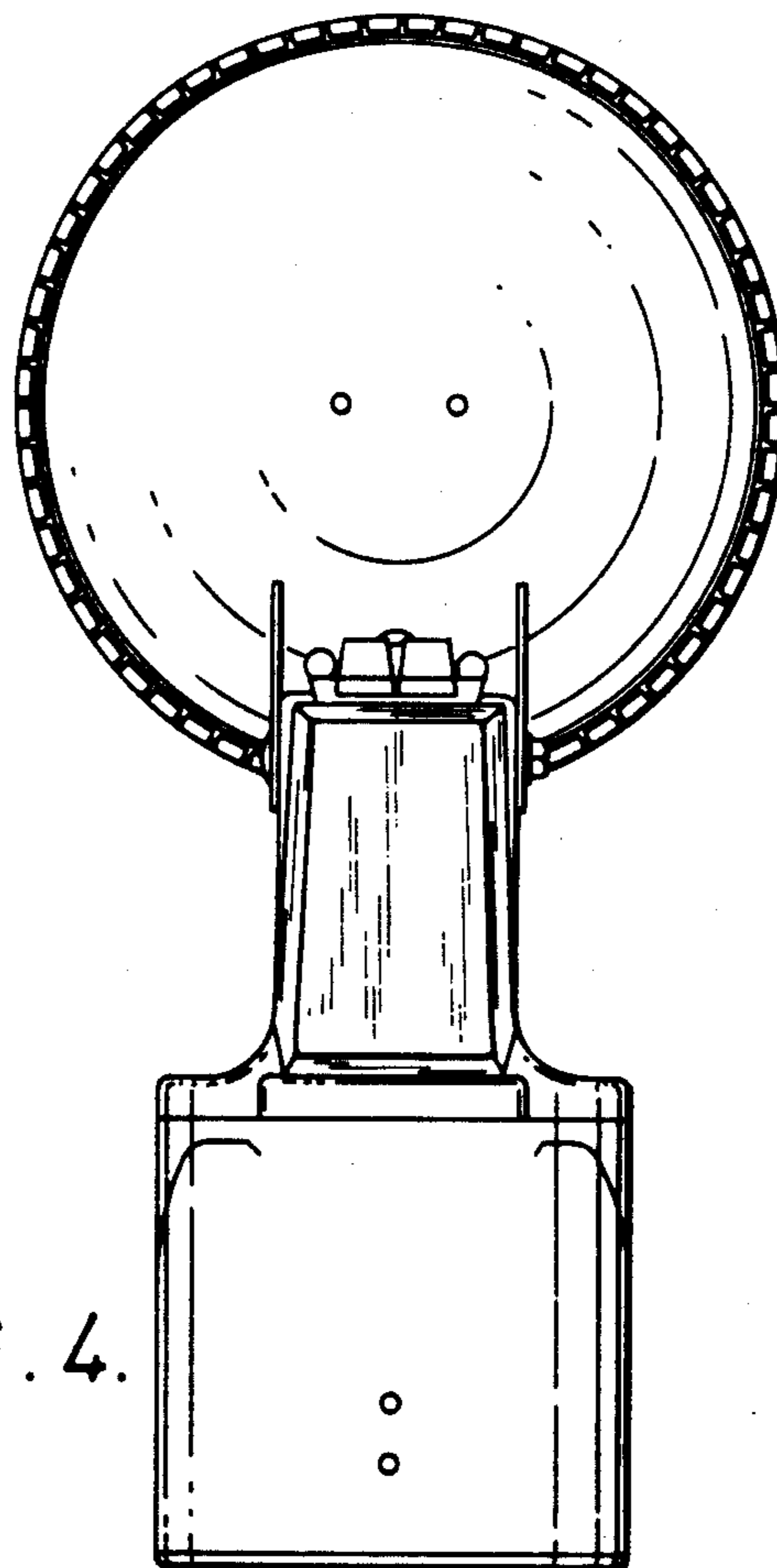

FIG. 4.

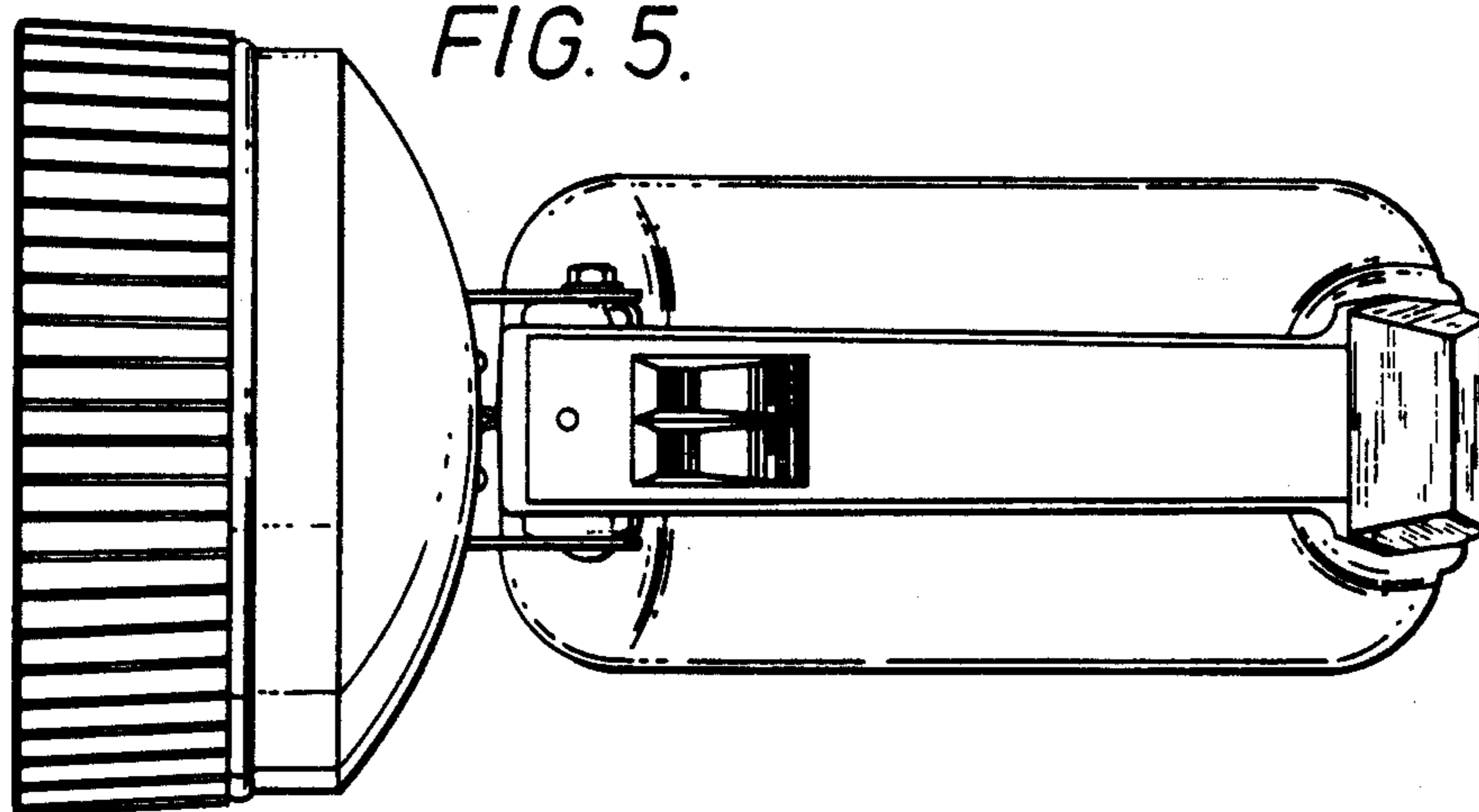

FIG. 5.