

[54] VEHICLE DISC BRAKE SHOE

[75] Inventors: Kurt H. Rinker, Ann Arbor; Anthony C. Evans, Westland, both of Mich.

[73] Assignee: Kelsey Hayes Co., Romulus, Mich.

[**] Term: 14 Years

[21] Appl. No.: 933,388

[22] Filed: Aug. 14, 1978

[51] Int. Cl. D12-16

[52] U.S. Cl. D12/180

[58] Field of Search D12/179, 180; 188/250 R, 250 H, 250 E, 250 G, 250 B, 250 A, 218 XL, 218 R, 73.1, 73.2, 73.3

[56] References Cited

U.S. PATENT DOCUMENTS

3,767,018 10/1973 Gordon 188/250 G

FOREIGN PATENT DOCUMENTS

2513131 9/1975 Fed. Rep. of Germany 188/250 E

OTHER PUBLICATIONS

Brake & Front End, Feb. 1977, P63, Disc Brake Pad, second box up from bottom left side of page.

Brake & Front End, May 1977, P6, Disc Brake Pad, 3, bottom center of page.

Primary Examiner—James M. Gandy

Attorney, Agent, or Firm—Ralph J. Skinkiss

[57] CLAIM

The ornamental design for a vehicle disc brake shoe, substantially as shown and described.

DESCRIPTION

FIG. 1 is a front elevational view of a vehicle disc brake shoe embodying our new design.

FIG. 2 is a rear elevational view thereof.

FIG. 3 is a top plan view thereof.

FIG. 4 is a bottom plan view thereof.

FIG. 5 is an end elevational view thereof.

FIG. 6 is a cross-sectional view thereof taken along line 6-6 of FIG. 1.

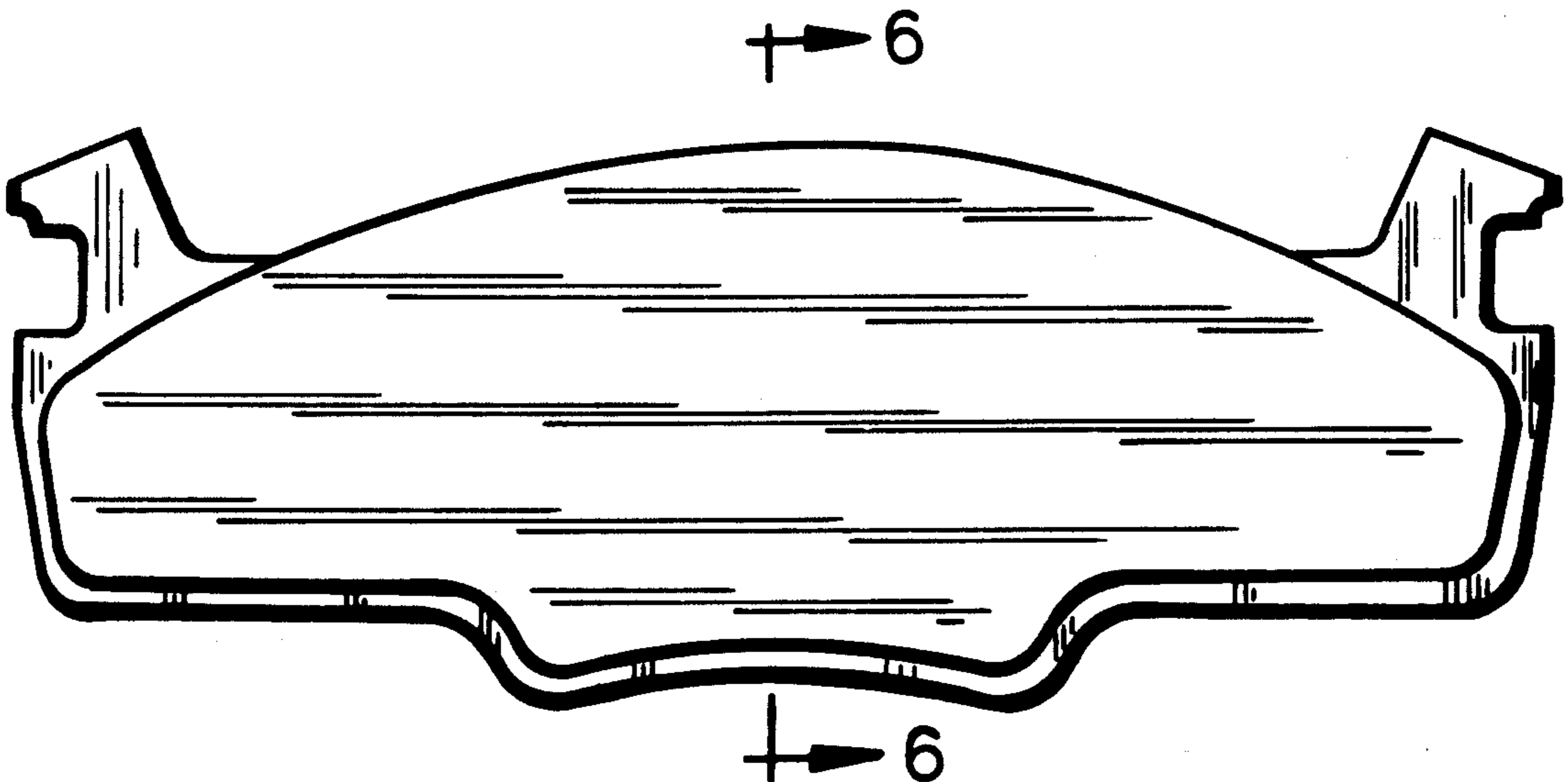

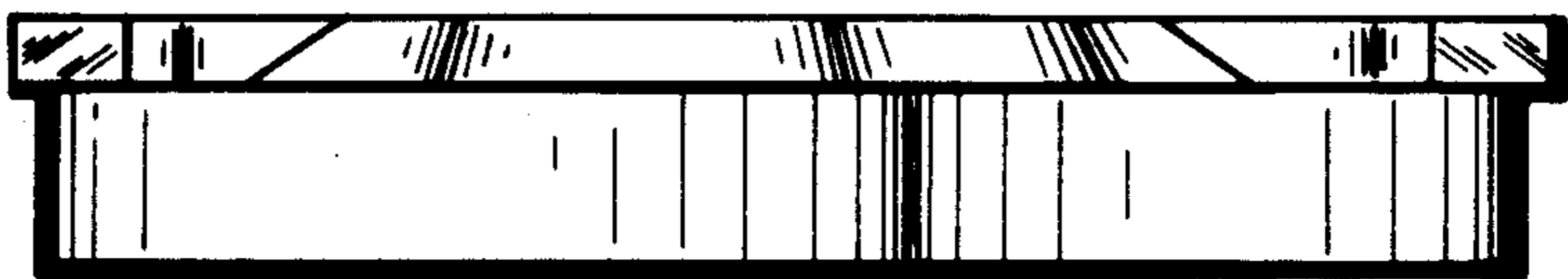

—FIG. 3

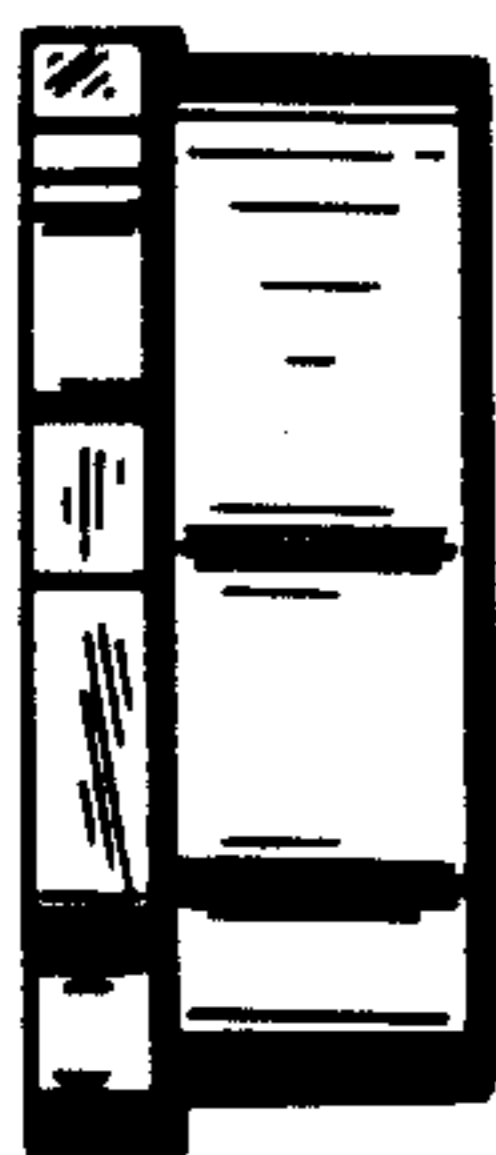

—FIG. 5

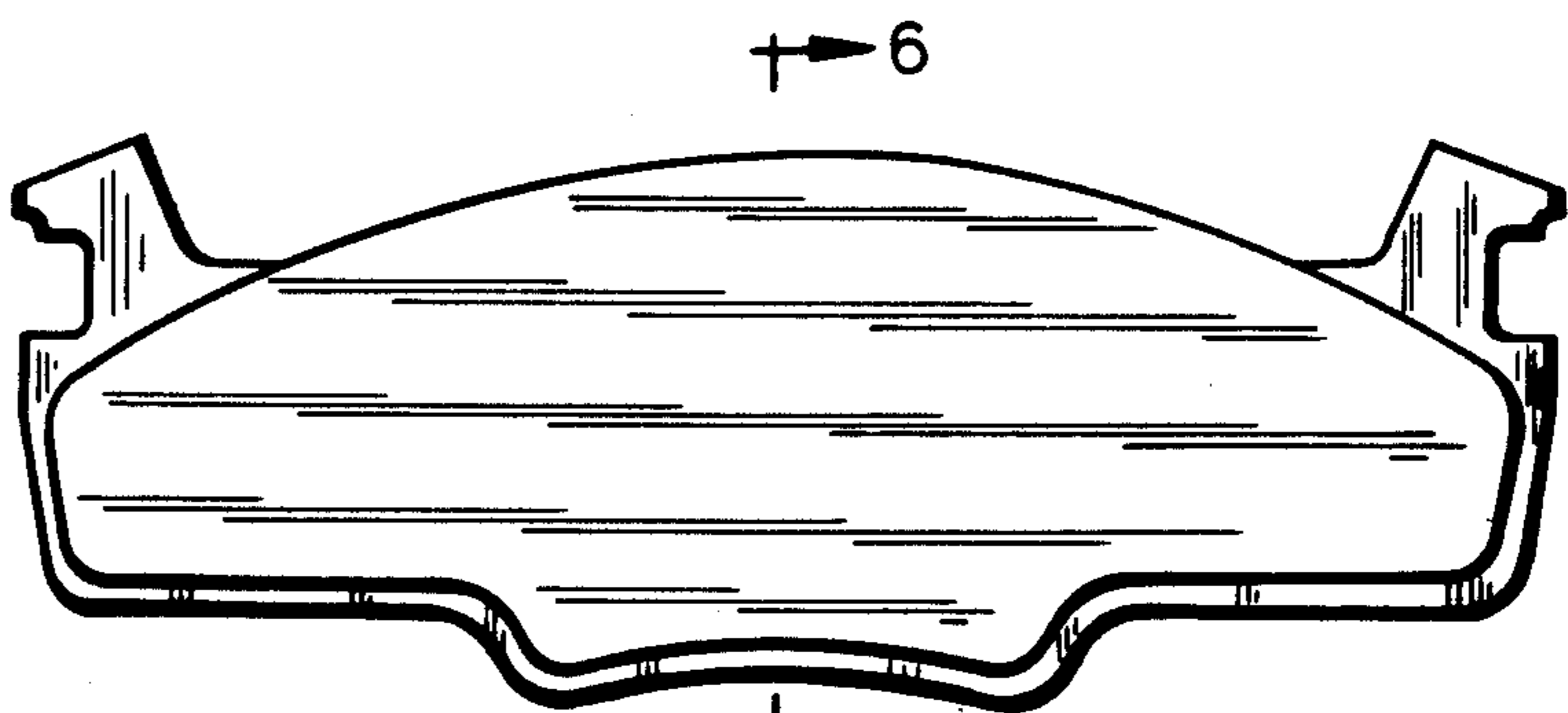

—FIG. 1

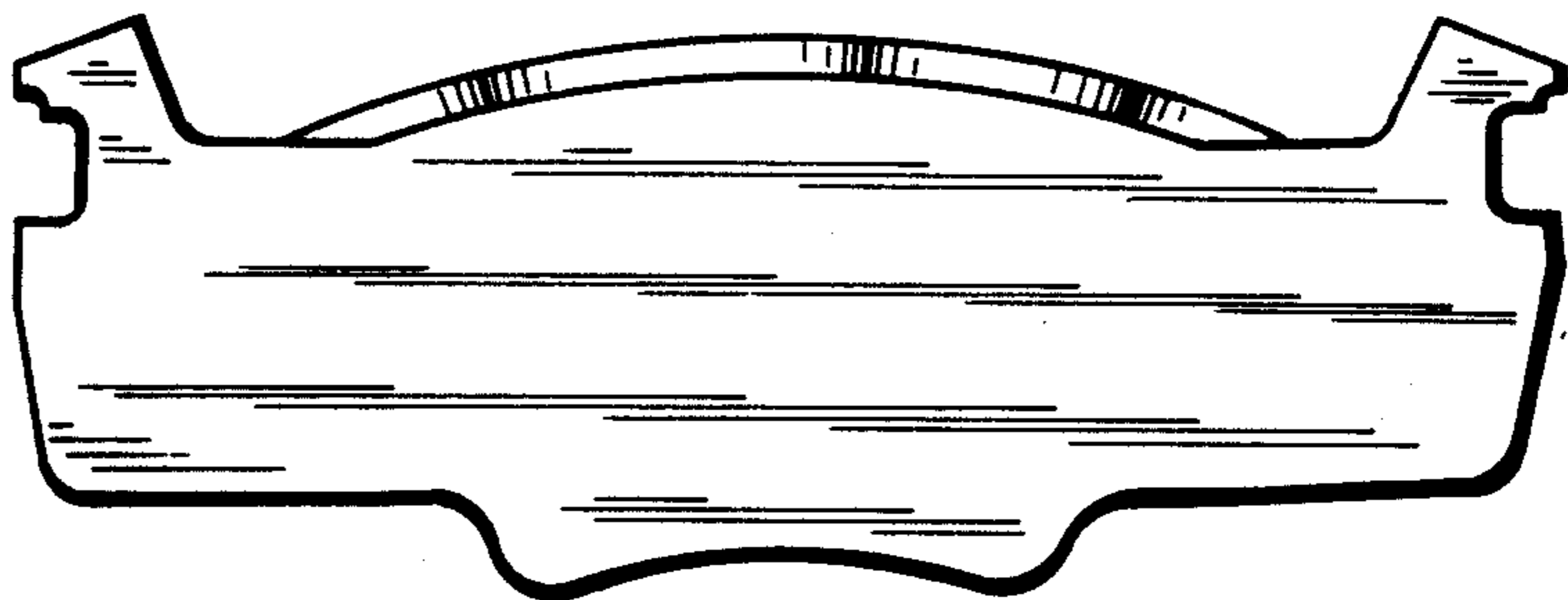

—FIG. 2

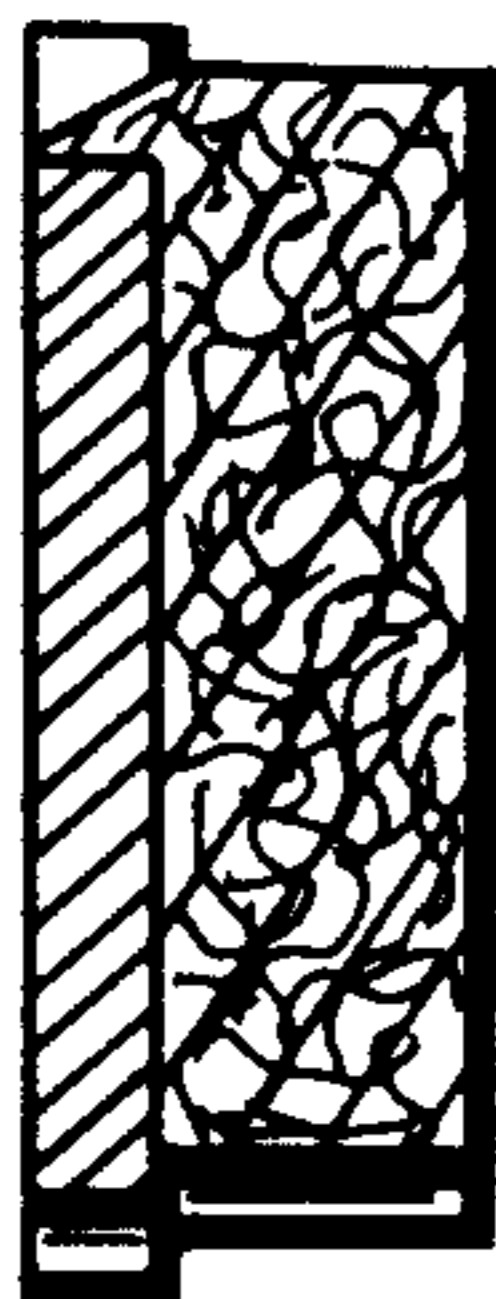

—FIG. 6

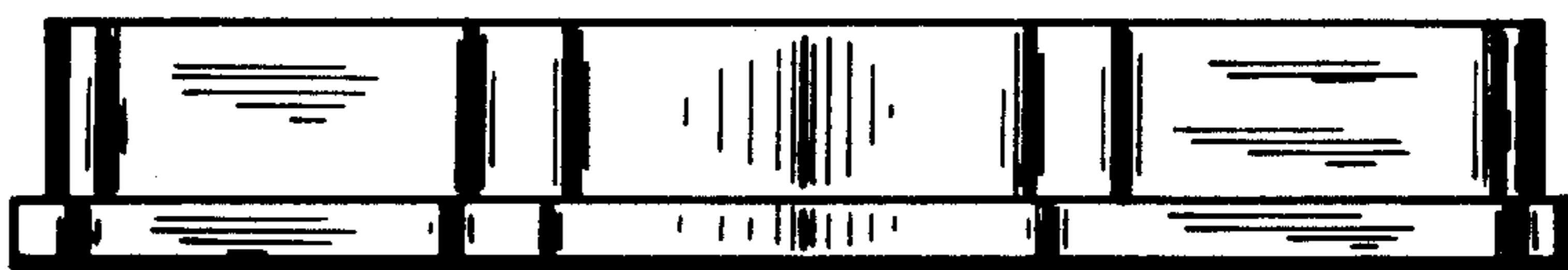

—FIG. 4