

[54] WHEEL BALANCER

4,149,416 4/1979 Harant ..... 73/462

[75] Inventor: Yuki Yoshi Hihara, Fujinomiya, Japan

[73] Assignee: Yasui Sangyo Co., Ltd., Fujinomiya, Japan

[\*\*] Term: 14 Years

[21] Appl. No.: 858,721

[22] Filed: Dec. 8, 1977

[51] Int. Cl. .... D10-04

[52] U.S. Cl. .... D10/82

[58] Field of Search ..... D10/82; 73/66, 462, 73/475

[56] References Cited

U.S. PATENT DOCUMENTS

3,636,773 1/1972 Harant ..... 73/475 X

OTHER PUBLICATIONS

Modern Tire Dealer, 7/77, p. 73, Wheel Balancer.  
Modern Tire Dealer, 7/77, p. 35, Wheel Balancer.  
Modern Tire Dealer, 7/77, p. 80, Wheel Balancer at right.  
Modern Tire Dealer, 7/77, p. 86, Wheel Balancer at left.

Primary Examiner—Nelson C. Holtje  
Attorney, Agent, or Firm—Zarley, McKee, Thomte, Voorhees & Sease

[57] CLAIM

The ornamental design for a wheel balancer, substantially as shown.

DESCRIPTION

FIG. 1 is a top and right front perspective view of a wheel balancer showing my new design;  
FIG. 2 is a top and left rear perspective view thereof.

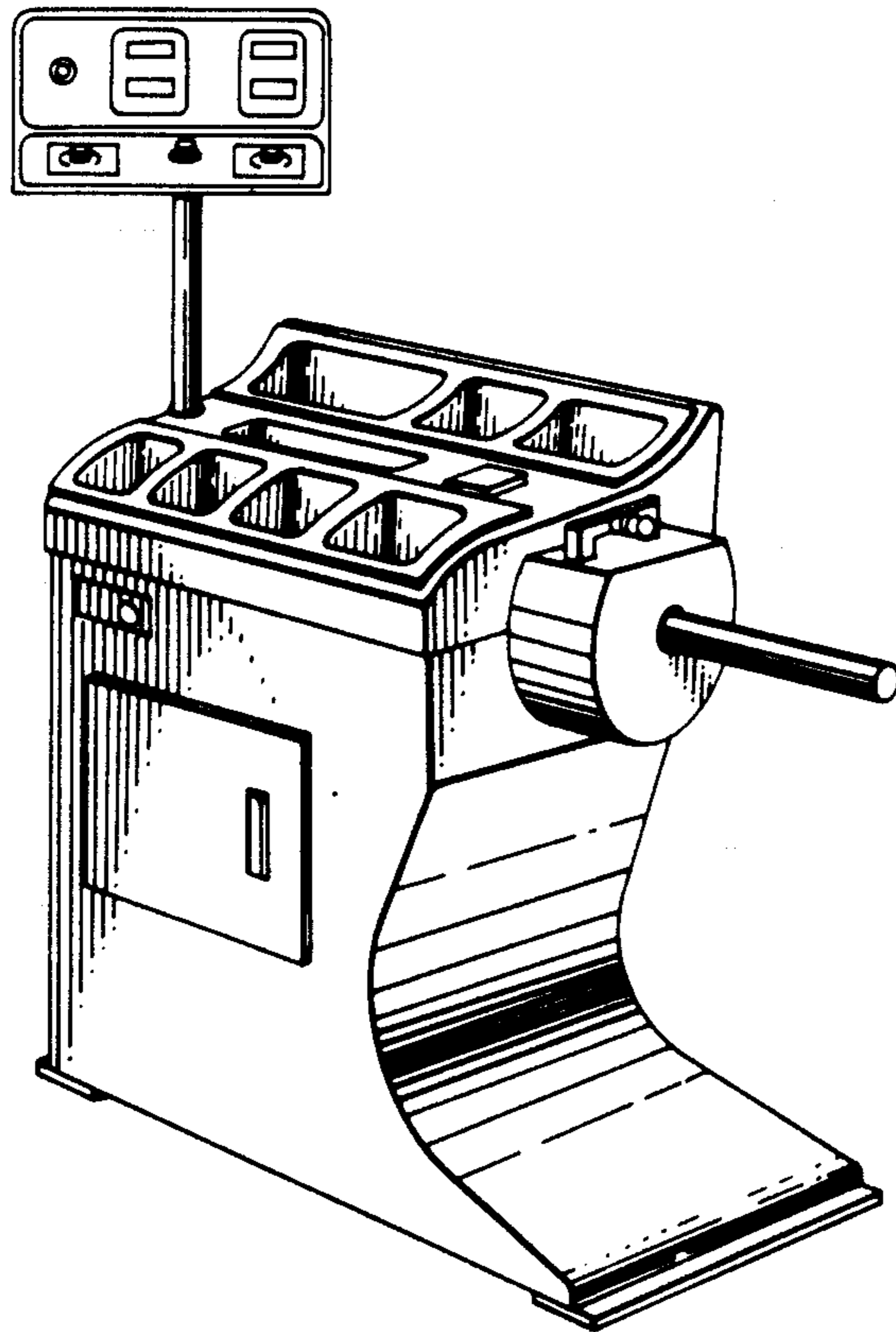
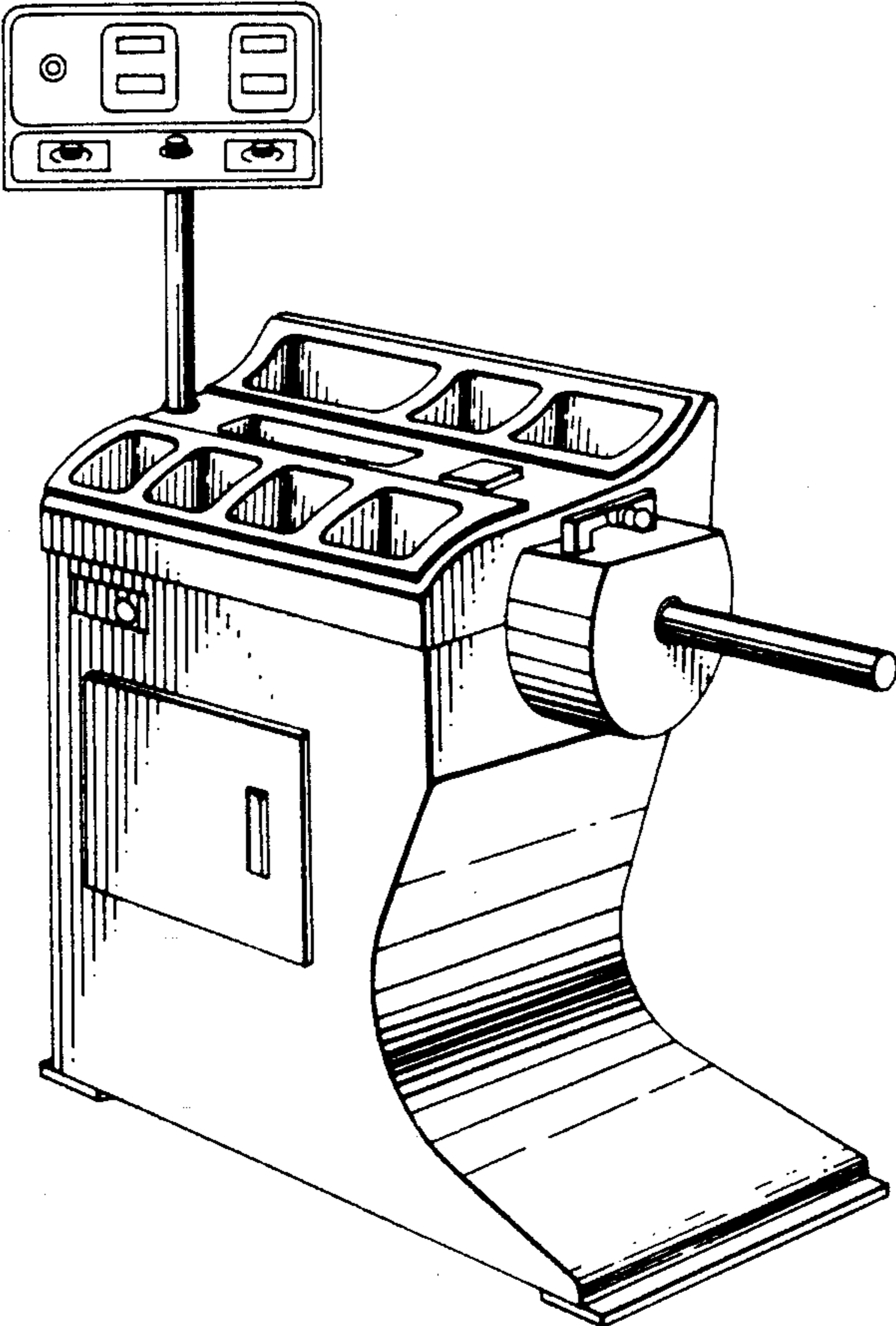

FIG. 1



F I G. 2

