

[54] RETAIL SALES BUILDING

[76] Inventors: Michael F. Adler; Alan S. Cohen; Cal F. Graser; Thomas R. Hamilton; Iver L. Johnson, all of Progressive Industries Corporation, 2030 Kuntz Rd., Dayton, Ohio 45404

[\*\*] Term: 14 Years

[21] Appl. No.: 957,043

[22] Filed: Nov. 2, 1978

[51] Int. Cl. .... D25-03

[52] U.S. Cl. .... D25/16; D25/23; D25/25; D25/33

[58] Field of Search ..... D25/1, 16, 18, 22, 23, D25/24, 25, 26, 33

[56] References Cited

U.S. PATENT DOCUMENTS

D. 117,586 11/1939 Tauriello ..... D25/16

OTHER PUBLICATIONS

Sweets Architectural Catalog File, 1976, Sect. 7.4/Ve, p. 4, Building at lower left.

Primary Examiner—A. Hugo Word  
Attorney, Agent, or Firm—William R. Jacox

[57] CLAIM

The new and ornamental design for retail sales building, substantially as shown and described.

DESCRIPTION

FIG. 1 is a perspective view of a retail sales building showing our new design.

FIG. 2 is a side elevational view thereof.

FIG. 3 is an end view thereof.

FIG. 4 is a side elevational view thereof, taken from the side opposite the side shown in FIG. 2.

FIG. 5 is an end elevational view thereof, taken from the end thereof opposite the end shown in FIG. 3.

FIG. 6 is a perspective view showing a modification in the retail sales building of this invention.

FIG. 7 is a perspective view showing another modification in the retail sales building of this invention.

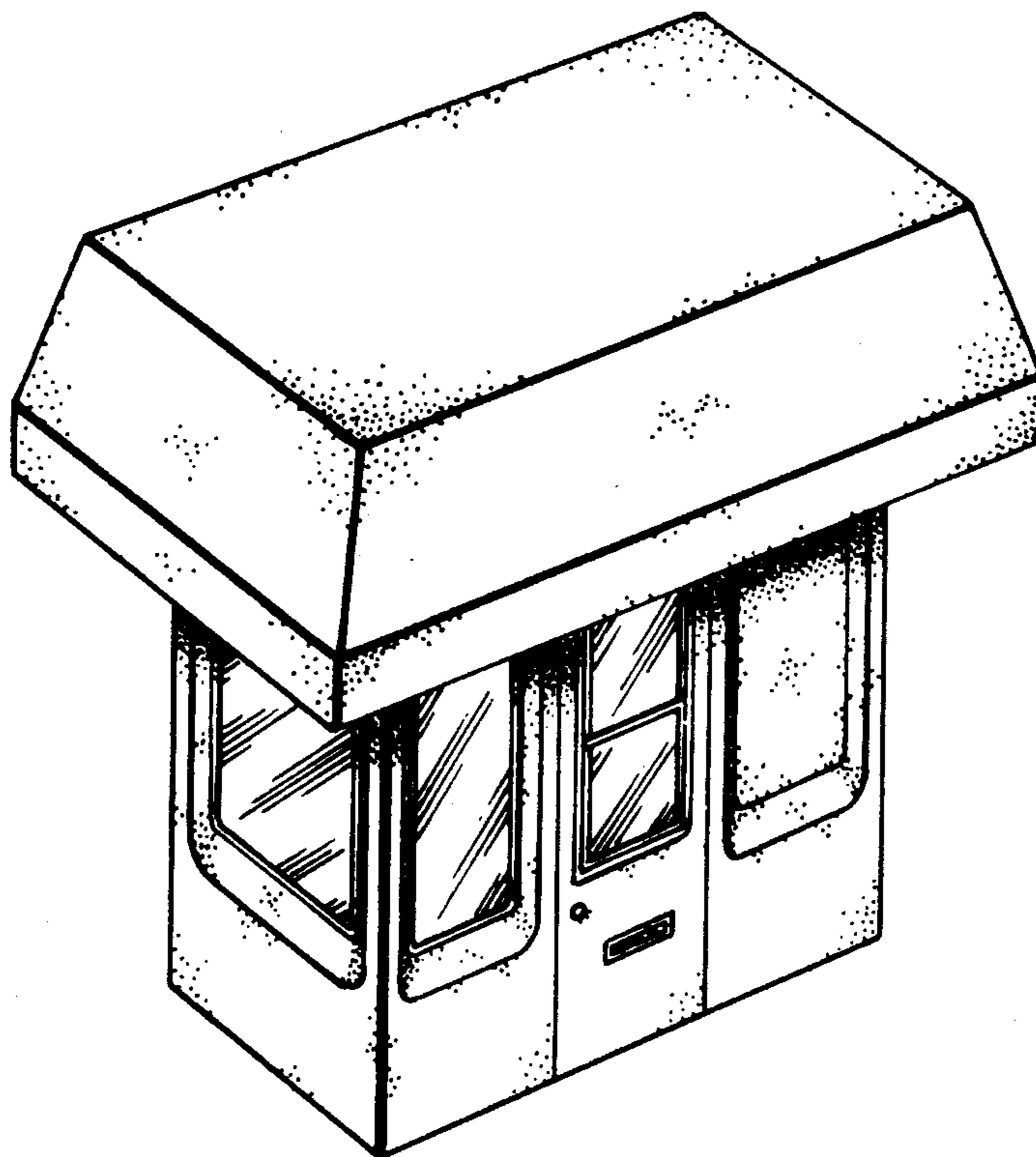

FIG-1

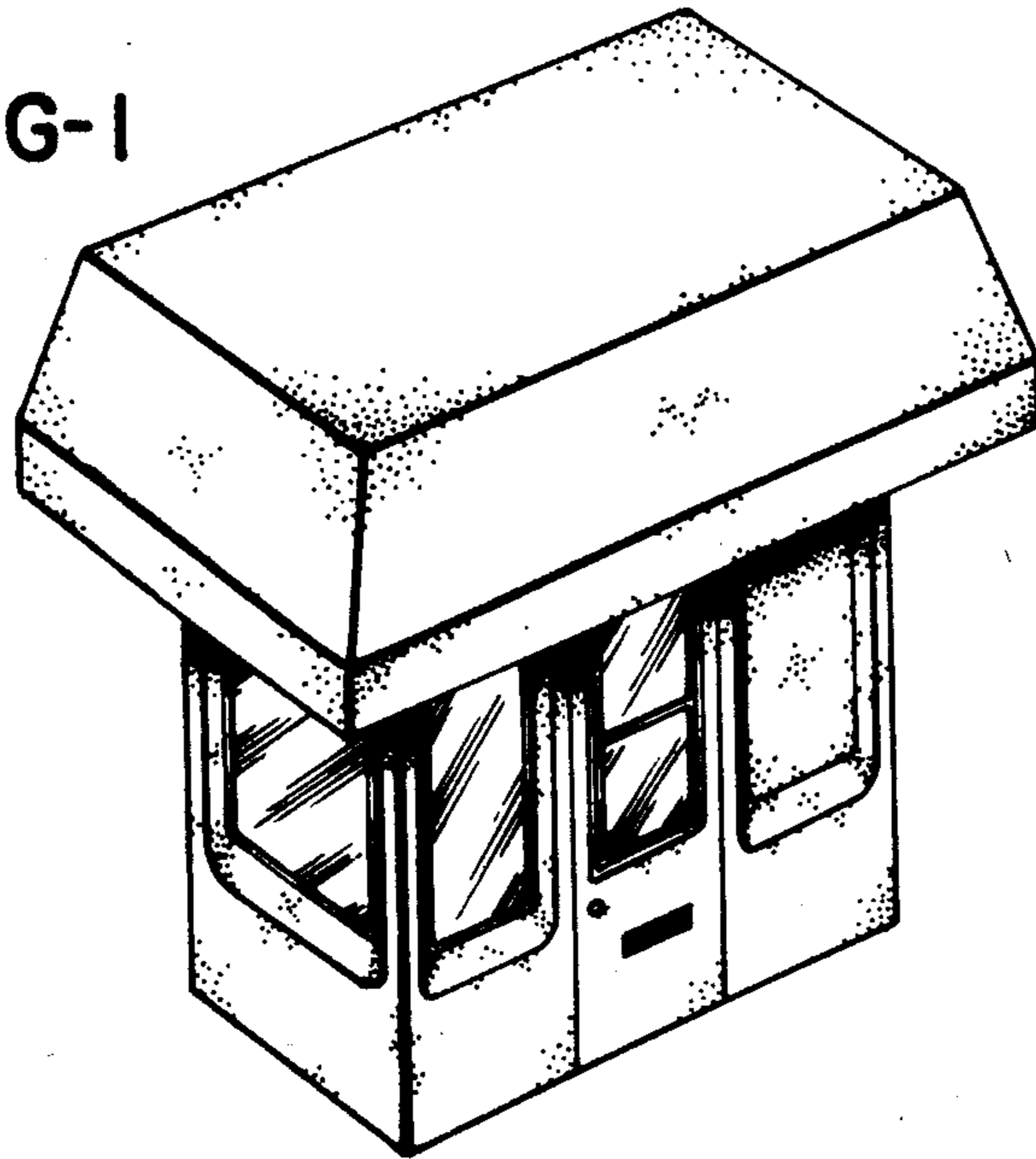

FIG-2

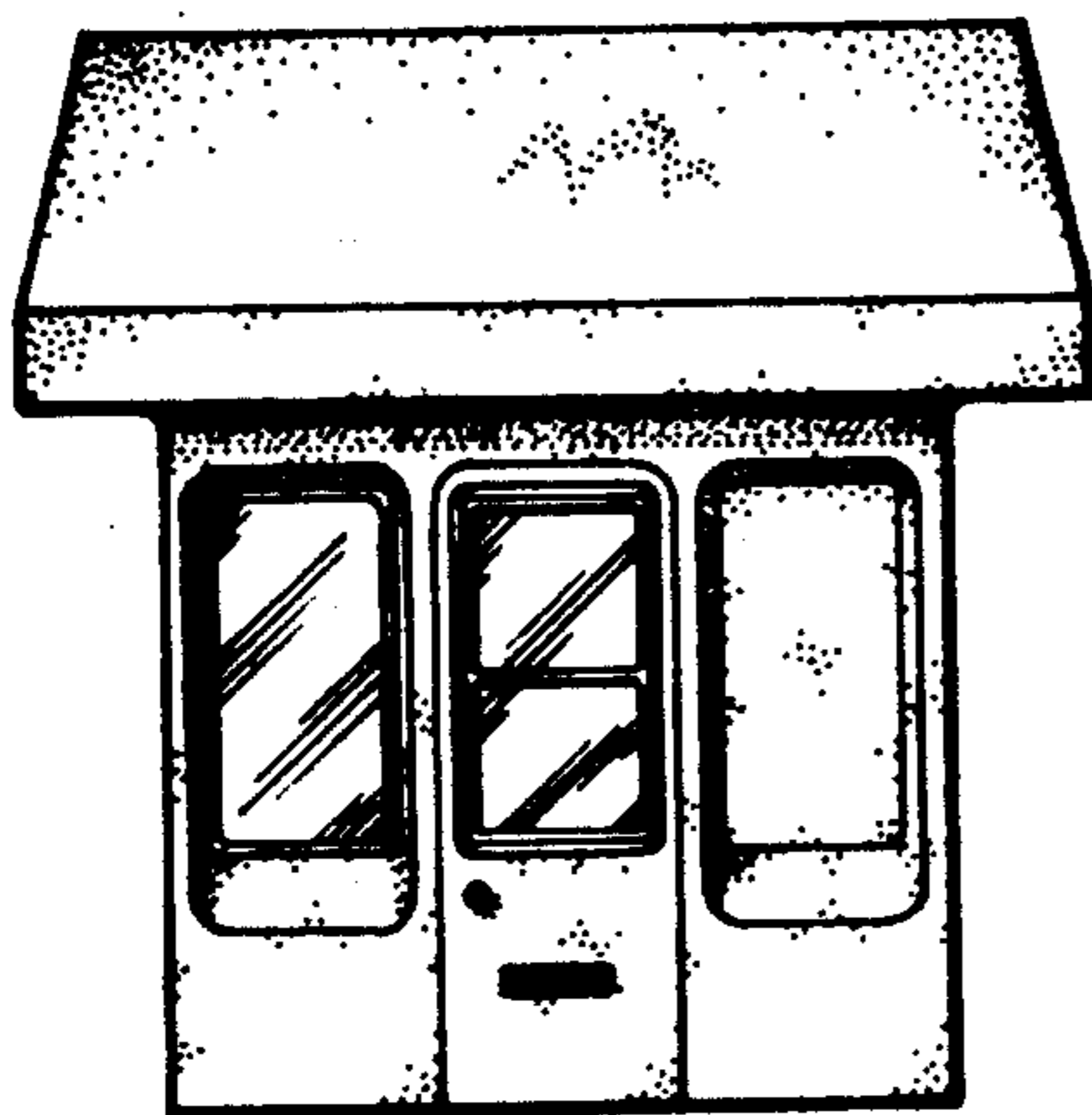

FIG-3

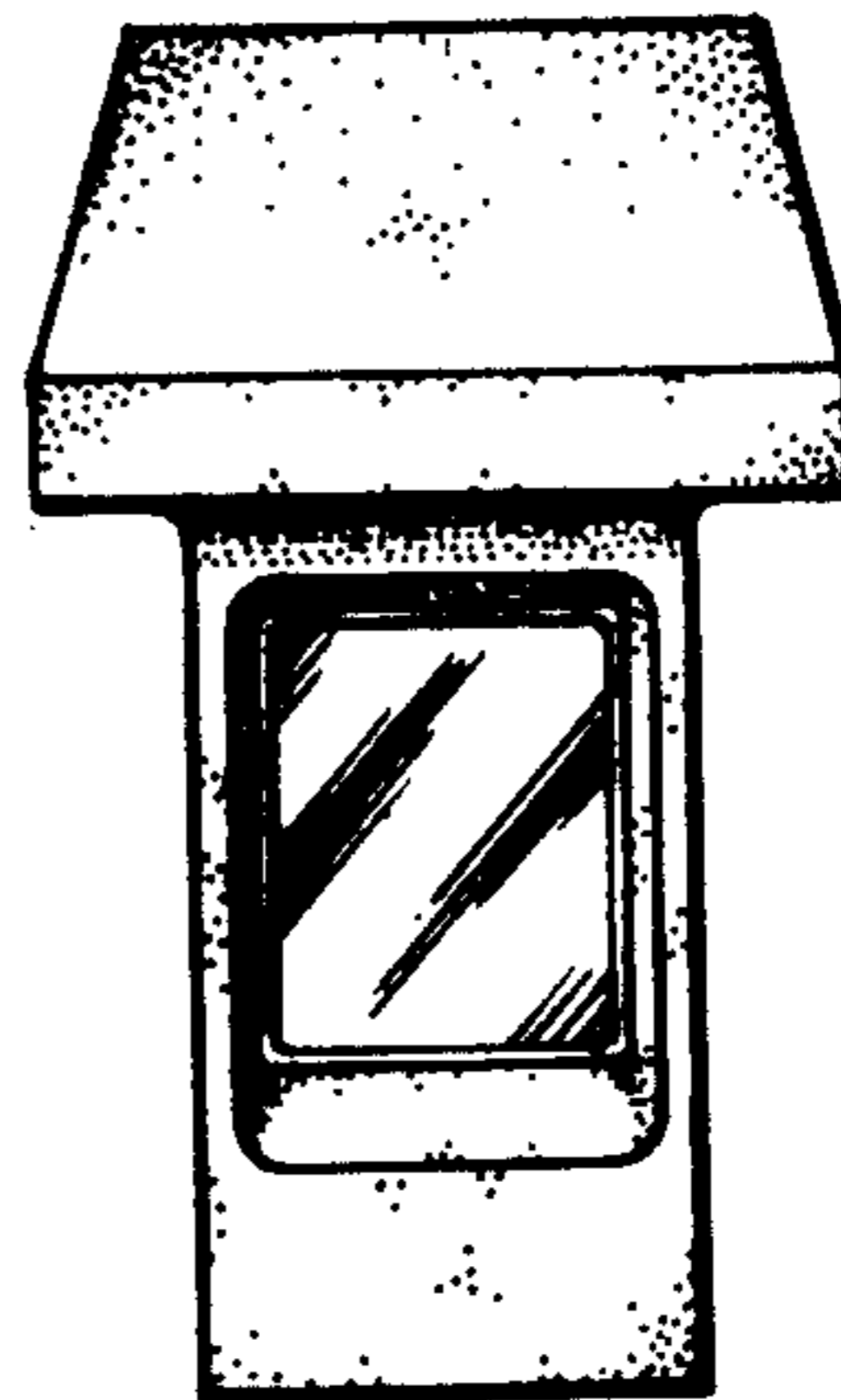

FIG-4

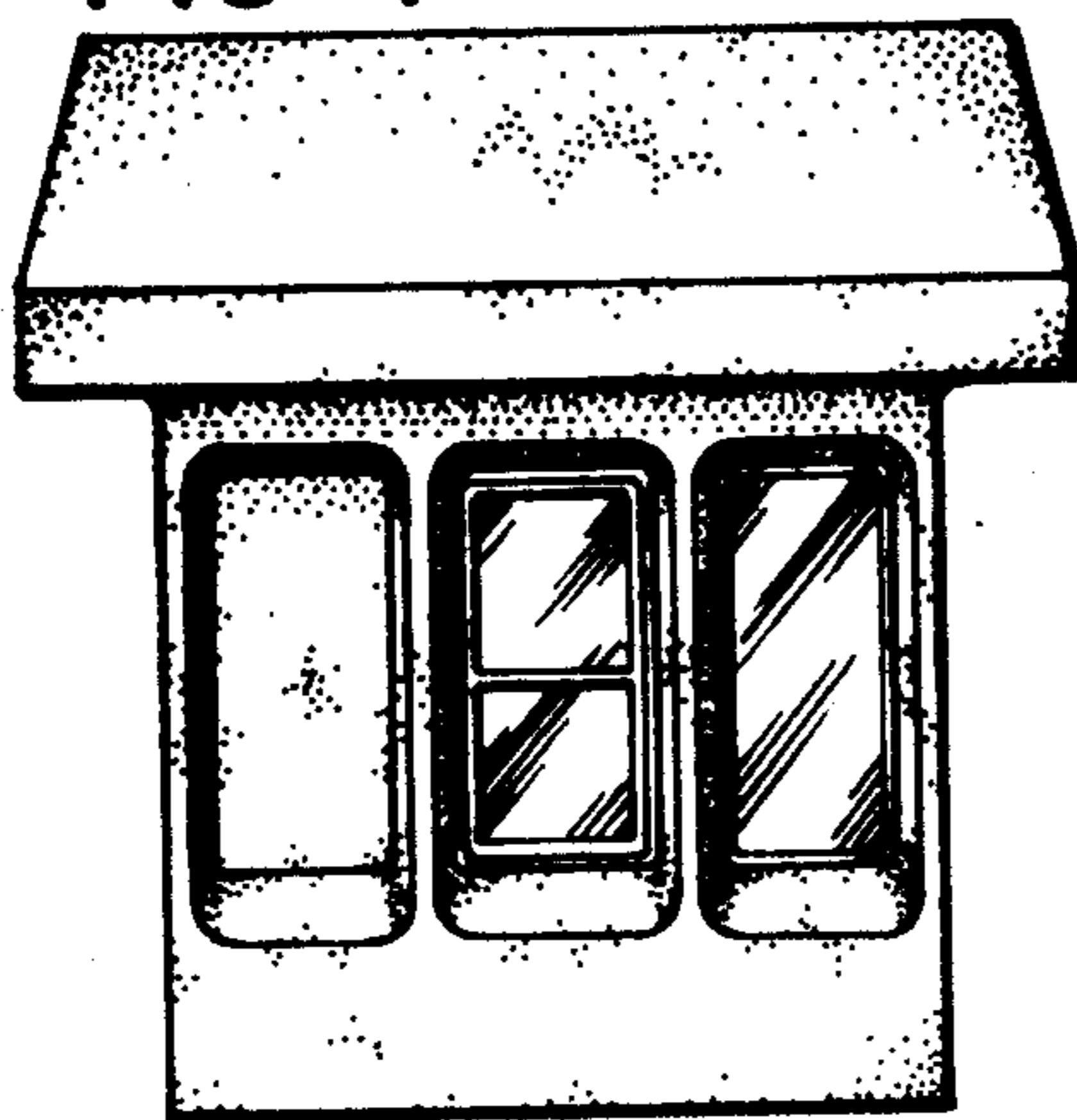

FIG-5

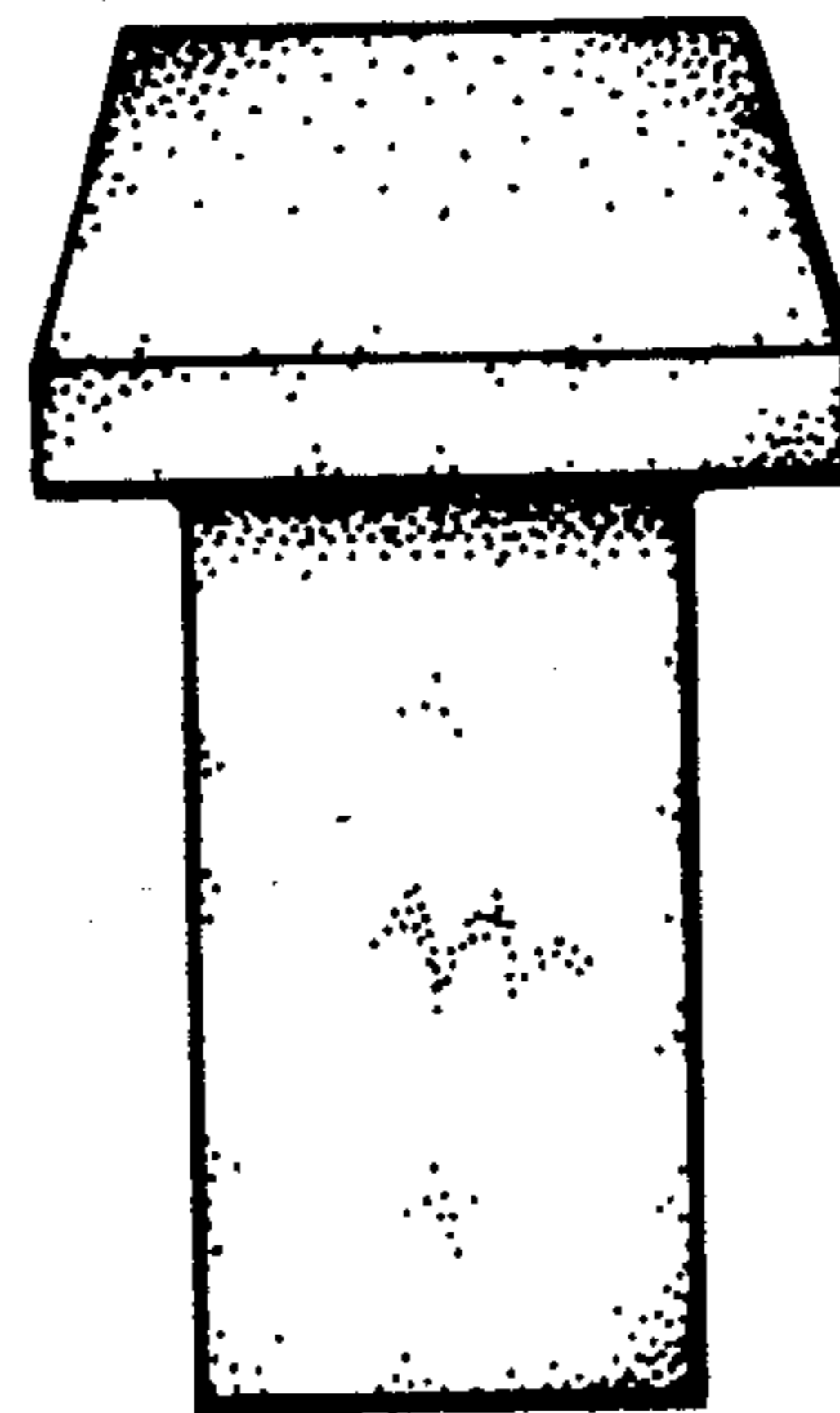

FIG-6

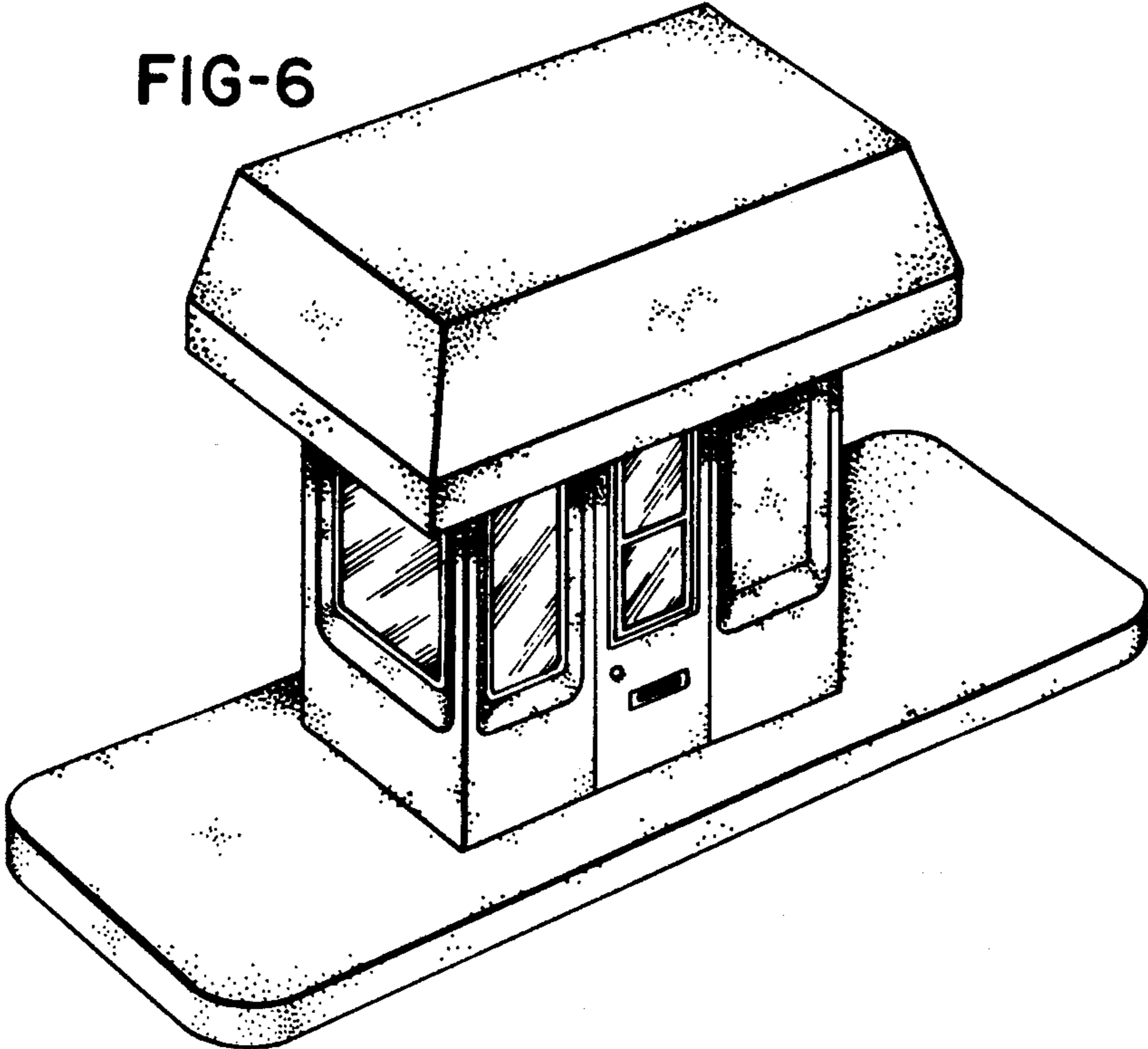

FIG-7

