

[54] **PRINTER FOR ELECTRICAL CASH REGISTER**

[75] **Inventors:** Shigeyoshi Hirabayashi; Chihiro Otsuki, both of Shiojiri, Japan

[73] **Assignees:** Kabushiki Kaisha Suwa Seikosha; Shinshuseiki Kabushiki Kaisha, both of Japan

[\*\*] **Term:** 14 Years

[21] **Appl. No.:** 861,483

[22] **Filed:** Dec. 16, 1977

[30] **Foreign Application Priority Data**

Jul. 16, 1977 [JP] Japan ..... 52-23433

[51] **Int. Cl.** ..... D18-01

[52] **U.S. Cl.** ..... D18/4; 235/58 P

[58] **Field of Search** ..... D14/50; D18/1, 3, 4, D18/6, 8, 13, 20, 22; 101/93.04, 93.24; 235/58 P, 60 P; 364/404, 405; 400/220, 220.1, 220.2, 221, 221.1, 221.2, 222, 611

[56] **References Cited**

**U.S. PATENT DOCUMENTS**

1,362,792	12/1920	Hayes .....	235/58 P
1,520,727	12/1924	Sippert .....	235/58 P
3,835,770	12/1974	Shimodaira et al. ....	400/221.2
4,046,246	9/1977	Kondlir, Jr. ....	400/220.1

**FOREIGN PATENT DOCUMENTS**

1027824	4/1966	United Kingdom .....	235/58 P
---------	--------	----------------------	----------

*Primary Examiner*—George G. Stellar  
*Attorney, Agent, or Firm*—Blum, Kaplan, Friedman, Silberman & Beran

[57] **CLAIM**

The ornamental design for a printer for electrical cash register, as shown and described.

**DESCRIPTION**

FIG. 1 is a perspective view of a printer for electrical cash register showing our new design; FIG. 2 is a top plan view; FIG. 3 is a front elevational view; FIG. 4 is a side elevational view from the side opposite that shown in FIG. 1; FIG. 5 is a rear elevational view; and FIG. 6 is a bottom plan view. FIGS. 2-6 are drawn to a scale reduced from that employed in FIG. 1.

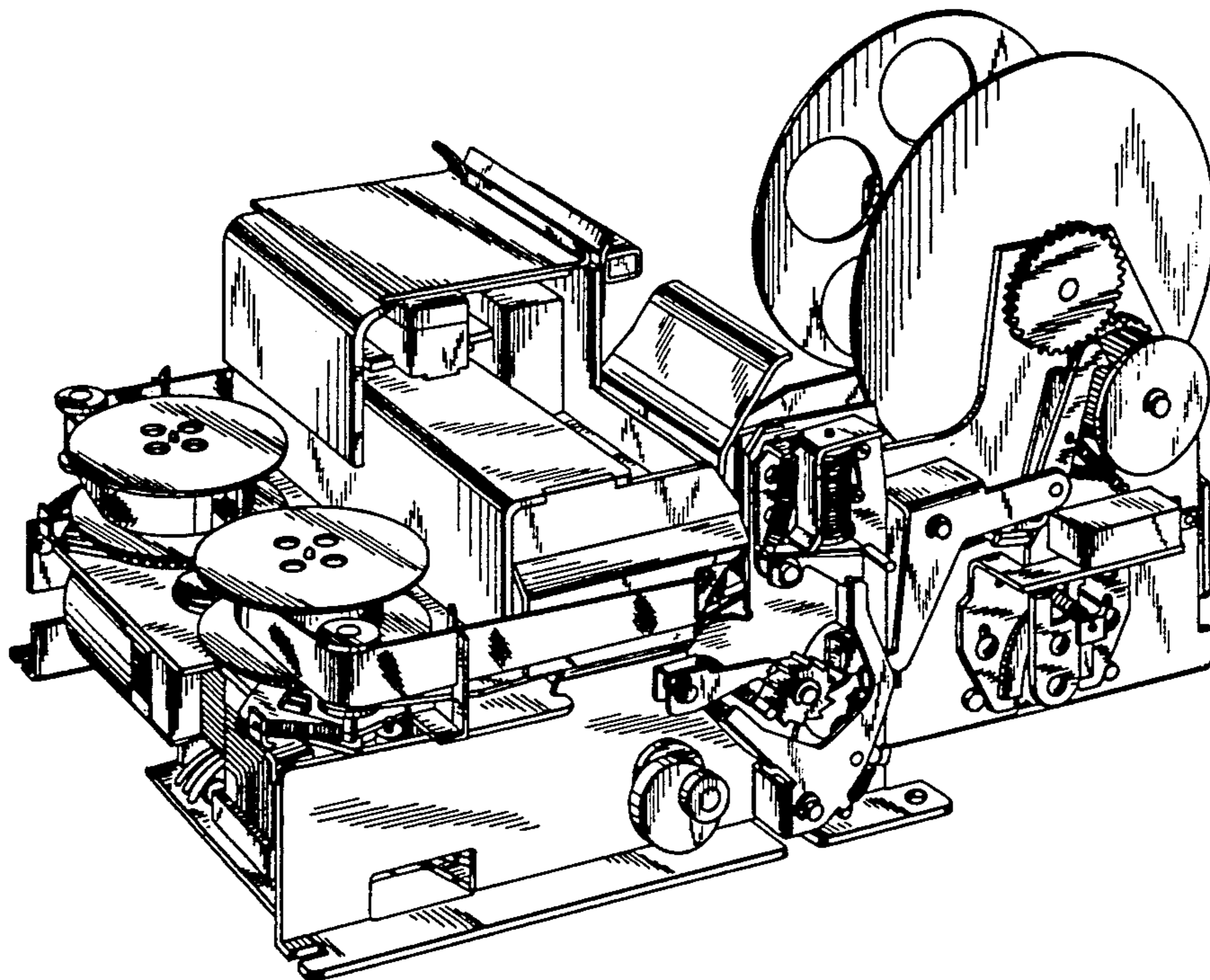

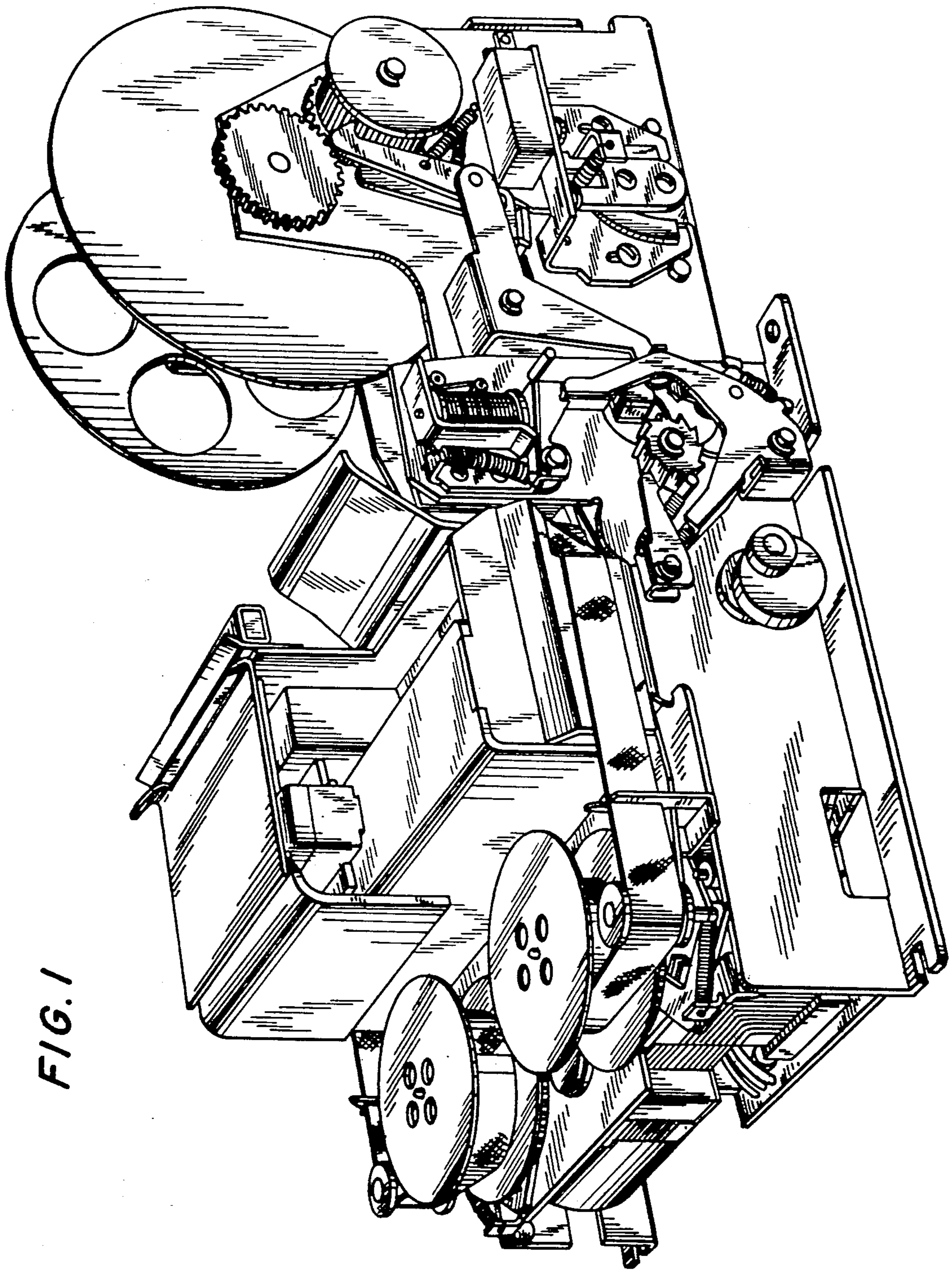
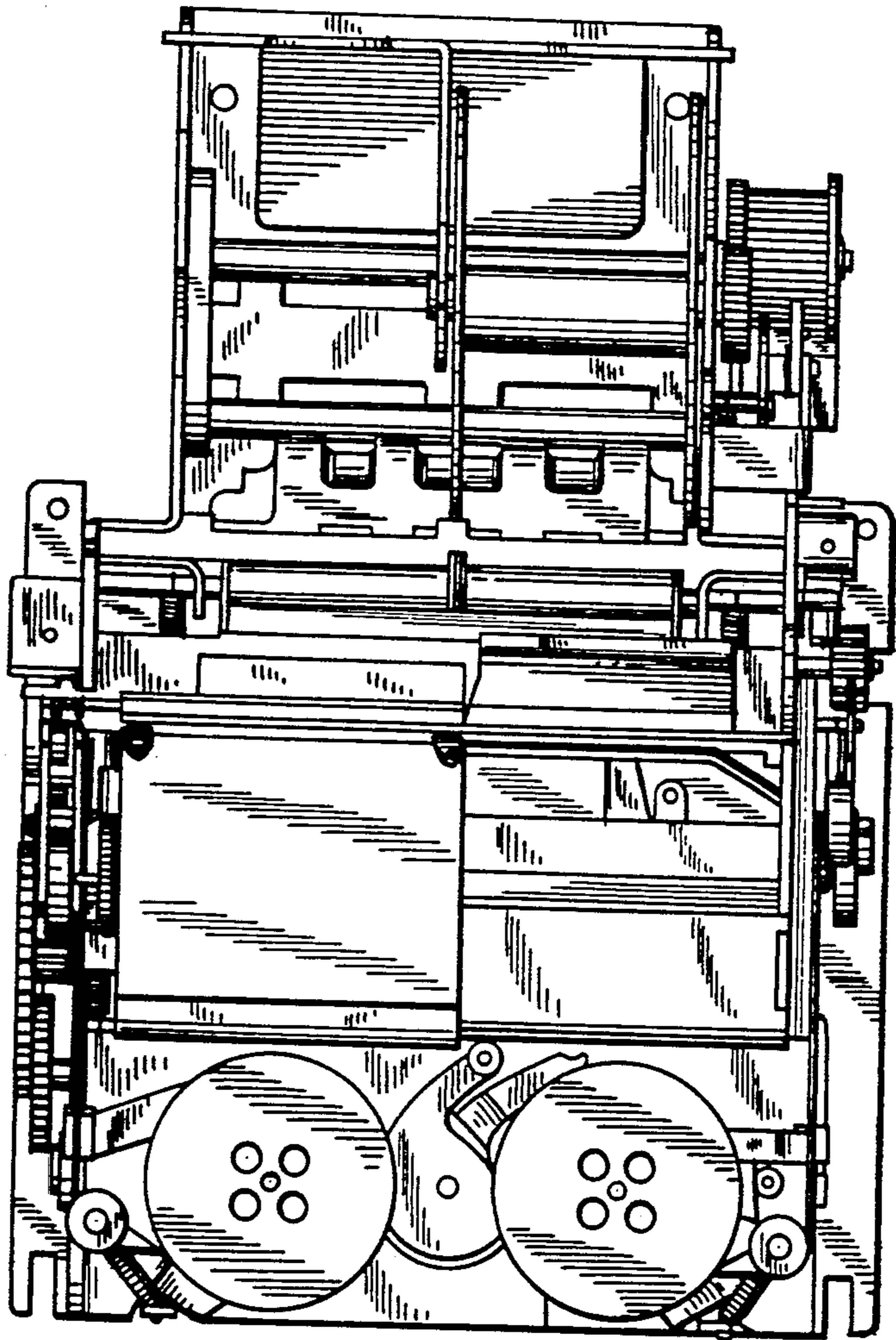

FIG. 1

*FIG. 2*



*FIG. 3*

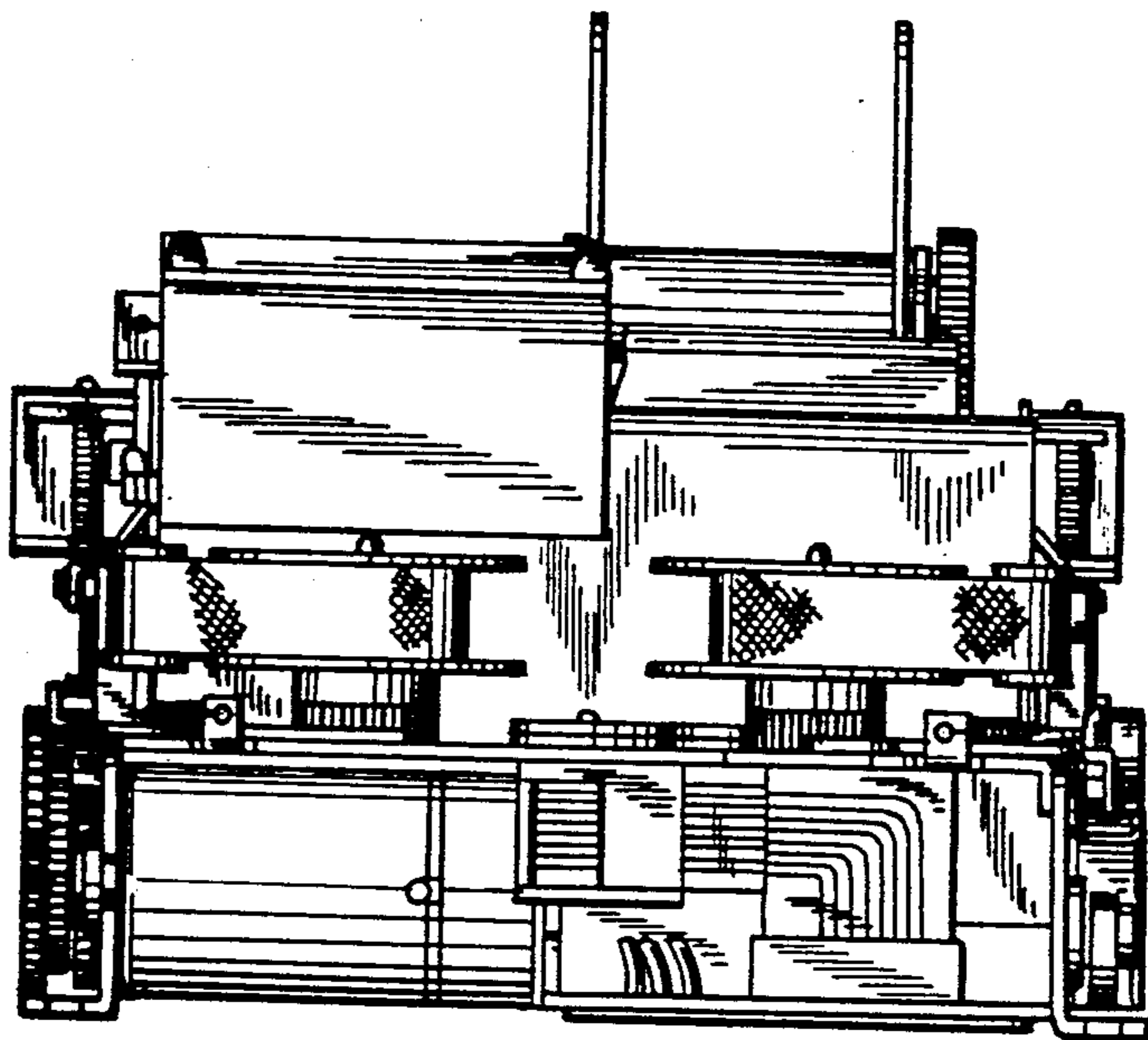
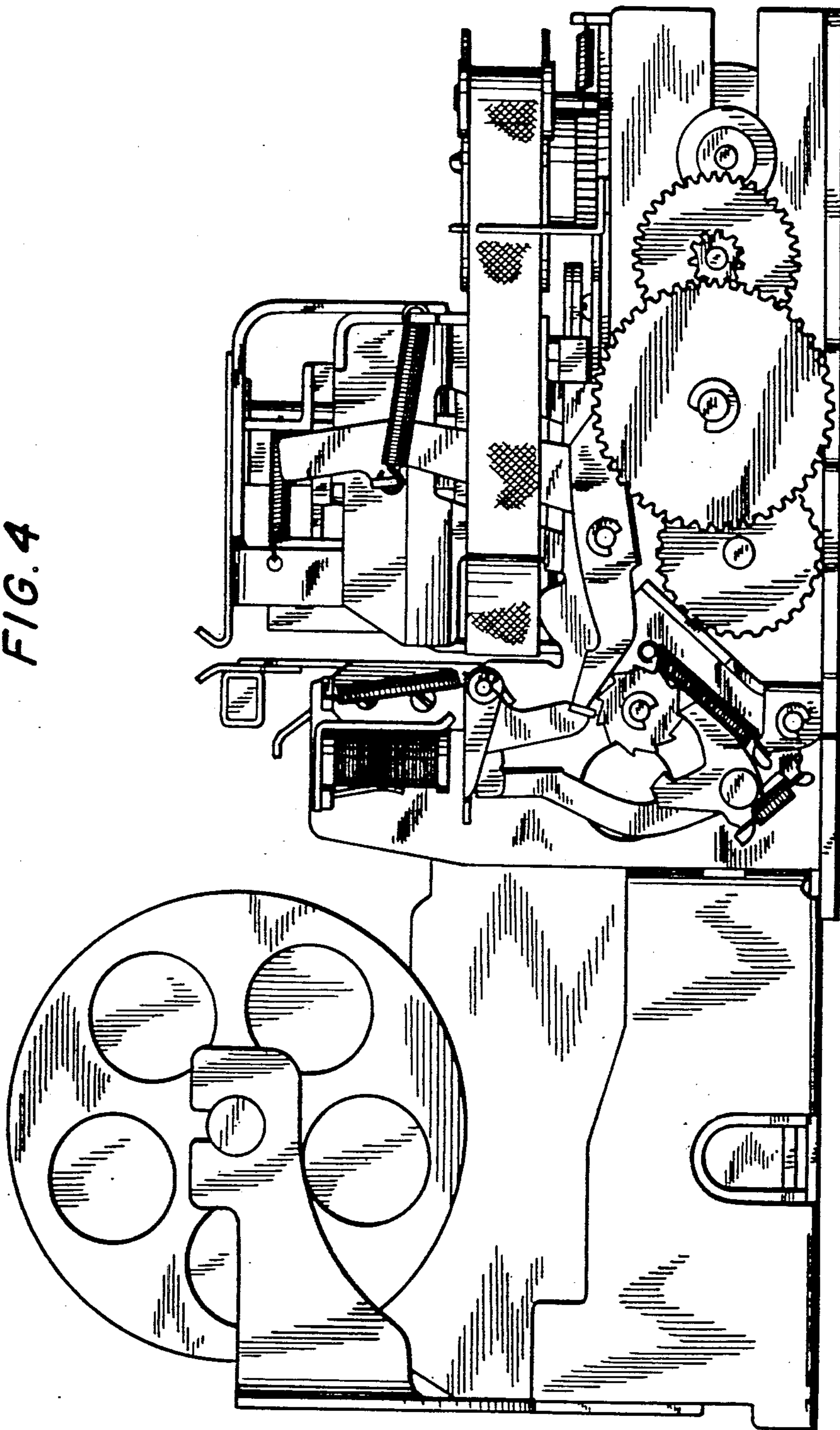
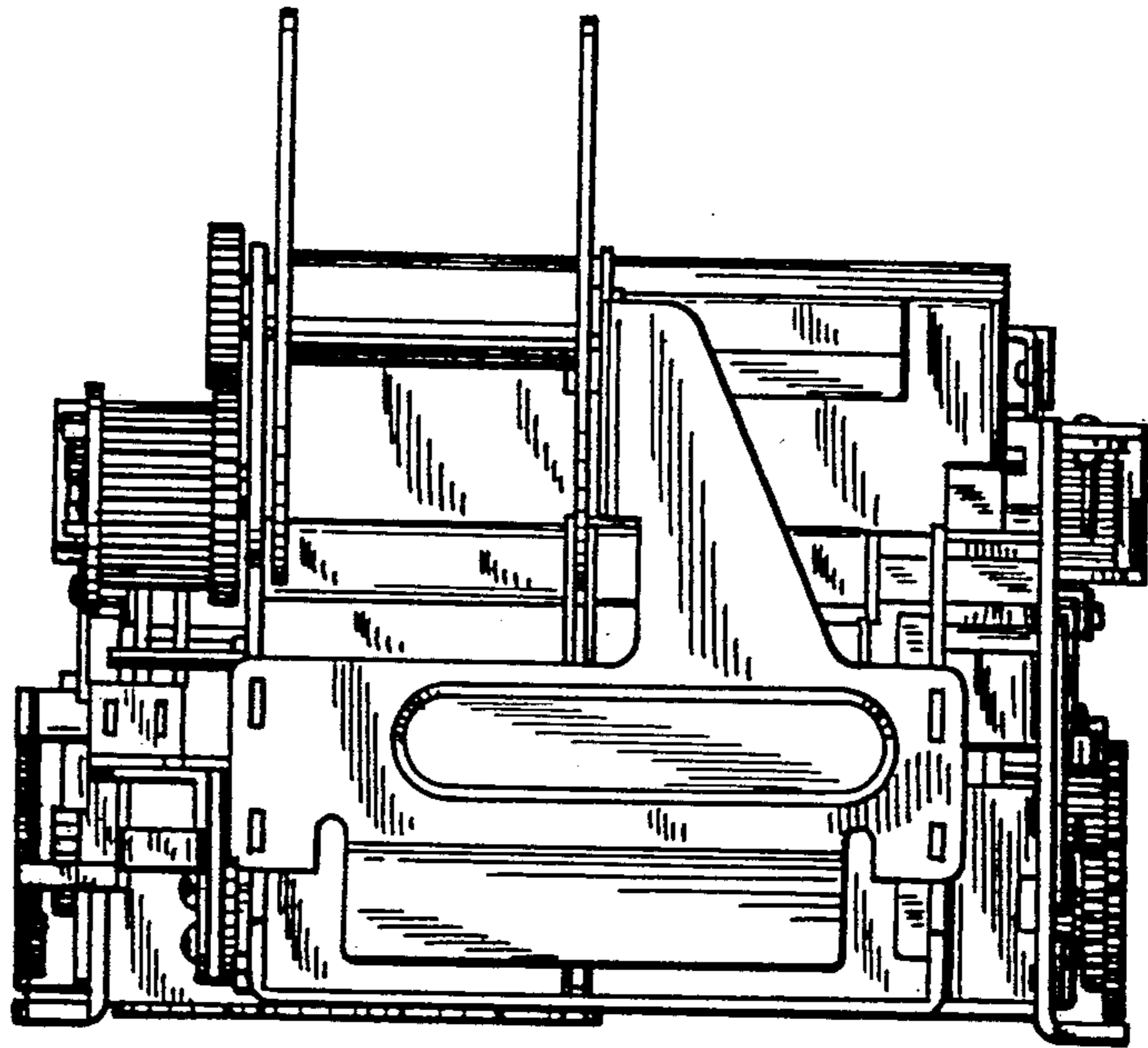

FIG. 4



**FIG. 5**



**FIG. 6**

