

[54] LOCKING ASSEMBLY FOR A DOOR
 [75] Inventor: Jacques Picard, Paris, France
 [73] Assignee: Societe Picard S.A., Paris, France
 [**] Term: 14 Years
 [21] Appl. No.: 813,611
 [22] Filed: Jul. 6, 1977
 [30] Foreign Application Priority Data
 Feb. 9, 1977 [FR] France..... 77 122232
 [51] Int. Cl. D08-07
 [52] U.S. Cl. D8/341
 [58] Field of Search D8/339, 341, 331, 344;
 70/108, 448, DIG. 63, 113, 118; 292/340, 42, 34

[56] References Cited
 U.S. PATENT DOCUMENTS
 1,277,174 8/1918 Bakst 70/108
 2,584,088 1/1952 Floyd 70/108
 FOREIGN PATENT DOCUMENTS
 523170 4/1931 Fed. Rep. of Germany 70/108
 944188 10/1948 France 292/340
 165757 3/1934 Switzerland 70/108

OTHER PUBLICATIONS
 Segal Locks & Hardware Catalog, P 14, Lock No. 1996,
 bottom of page.
 Segal Locks & Hardware Catalog, P 16, Cylinder Rim
 Deadlock No. 292, bottom of page.

Primary Examiner—James M. Gandy
 Attorney, Agent, or Firm—Haseltine, Lake & Waters

[57] CLAIM
 The ornamental design for a locking assembly for a door, as shown and described.

DESCRIPTION

FIG. 1 is a front elevational view of a locking assembly for a door showing my new design, the broken lines being for illustrative purposes only;
 FIG. 2 is a top plan view thereof;
 FIG. 3 is a left side elevational view thereof;
 FIG. 4 is a right side elevational view thereof;
 FIG. 5 is an enlarged top plan view of the center bolt lock of the assembly, the bottom being substantially a mirror image thereof;
 FIG. 6 is a left end elevational view of FIG. 5;
 FIG. 7 is a front elevational view of FIG. 5;
 FIG. 8 is a right end elevational view of FIG. 5;
 FIG. 9 is a rear elevational view of FIG. 5;
 FIG. 10 is an enlarged top plan view of either the upper or lower bolt lock of the assembly, the bottom being substantially a mirror image thereof;
 FIG. 11 is a left end elevational view of FIG. 10;
 FIG. 12 is a front elevational view of FIG. 10;
 FIG. 13 is a right end elevational view of FIG. 10;
 FIG. 14 is a rear elevational view of FIG. 10;
 FIG. 15 is an enlarged top plan view of the center strike plate of the assembly, the bottom being substantially a mirror image thereof;
 FIG. 16 is a left side elevational view of FIG. 15;
 FIG. 17 is a front elevational view of FIG. 15;
 FIG. 18 is a right side elevational view of FIG. 15;
 FIG. 19 is a rear elevational view of FIG. 15;
 FIG. 20 is an enlarged top plan view of either the upper or lower strike plate of the assembly, the bottom being substantially a mirror image thereof;
 FIG. 21 is a left side elevational view of FIG. 20;
 FIG. 22 is a front elevational view of FIG. 20;
 FIG. 23 is a right side elevational view of FIG. 20; and
 FIG. 24 is a rear elevational view of FIG. 20.

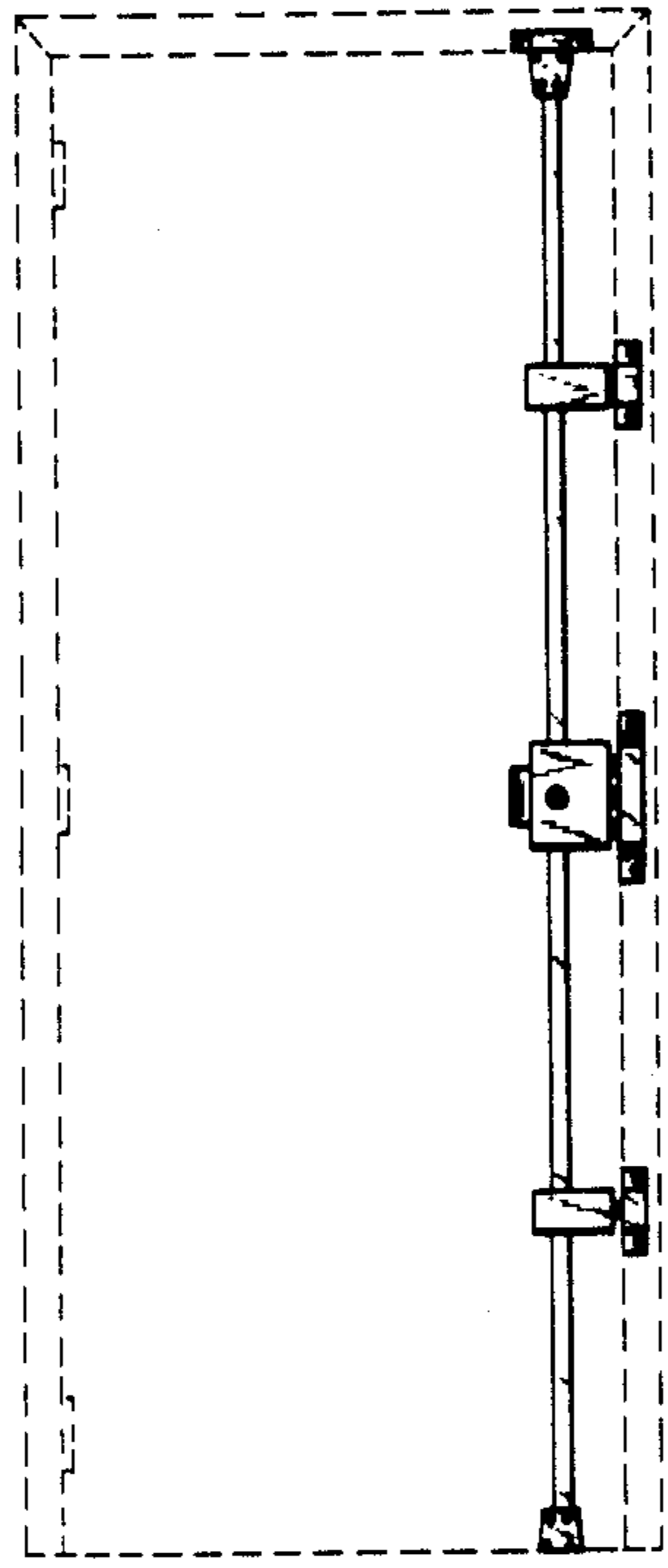

FIG. 2



FIG. 3

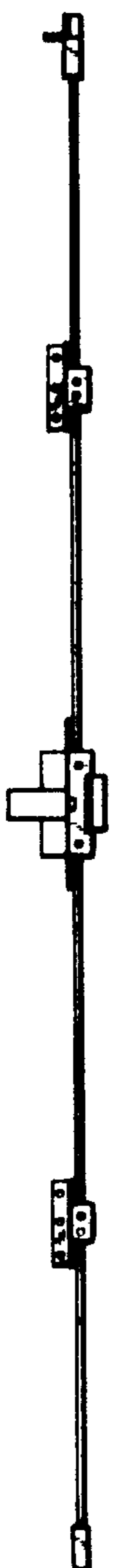

FIG. 1

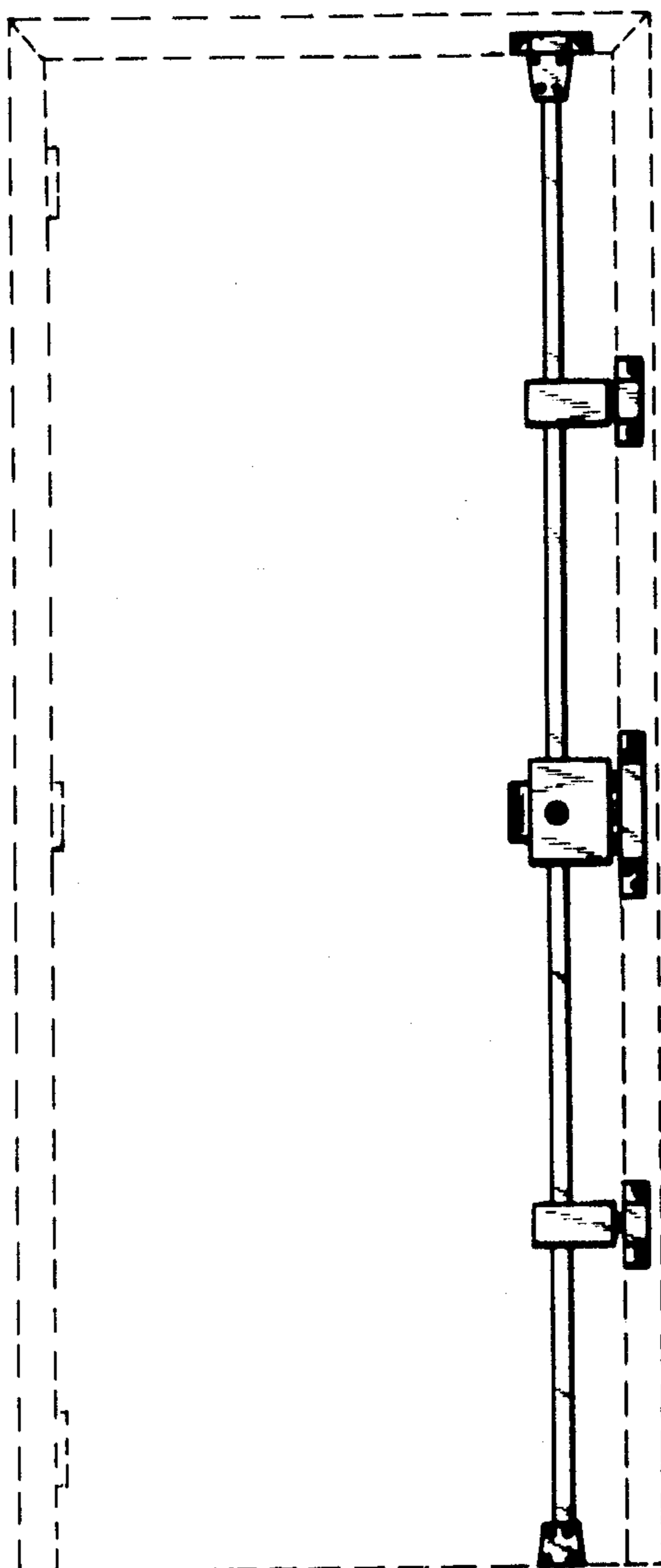

FIG. 4



FIG. 5

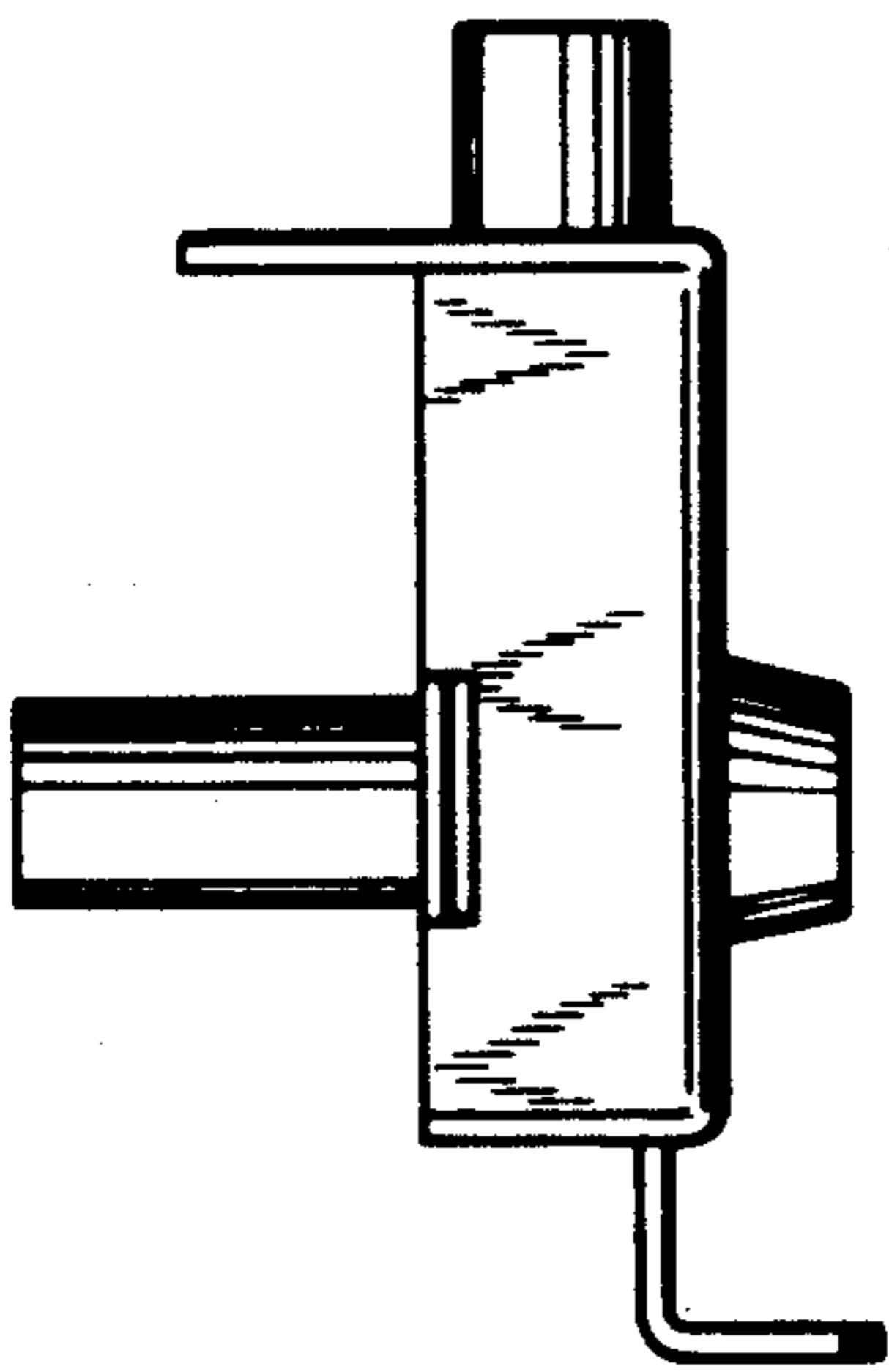

FIG. 9

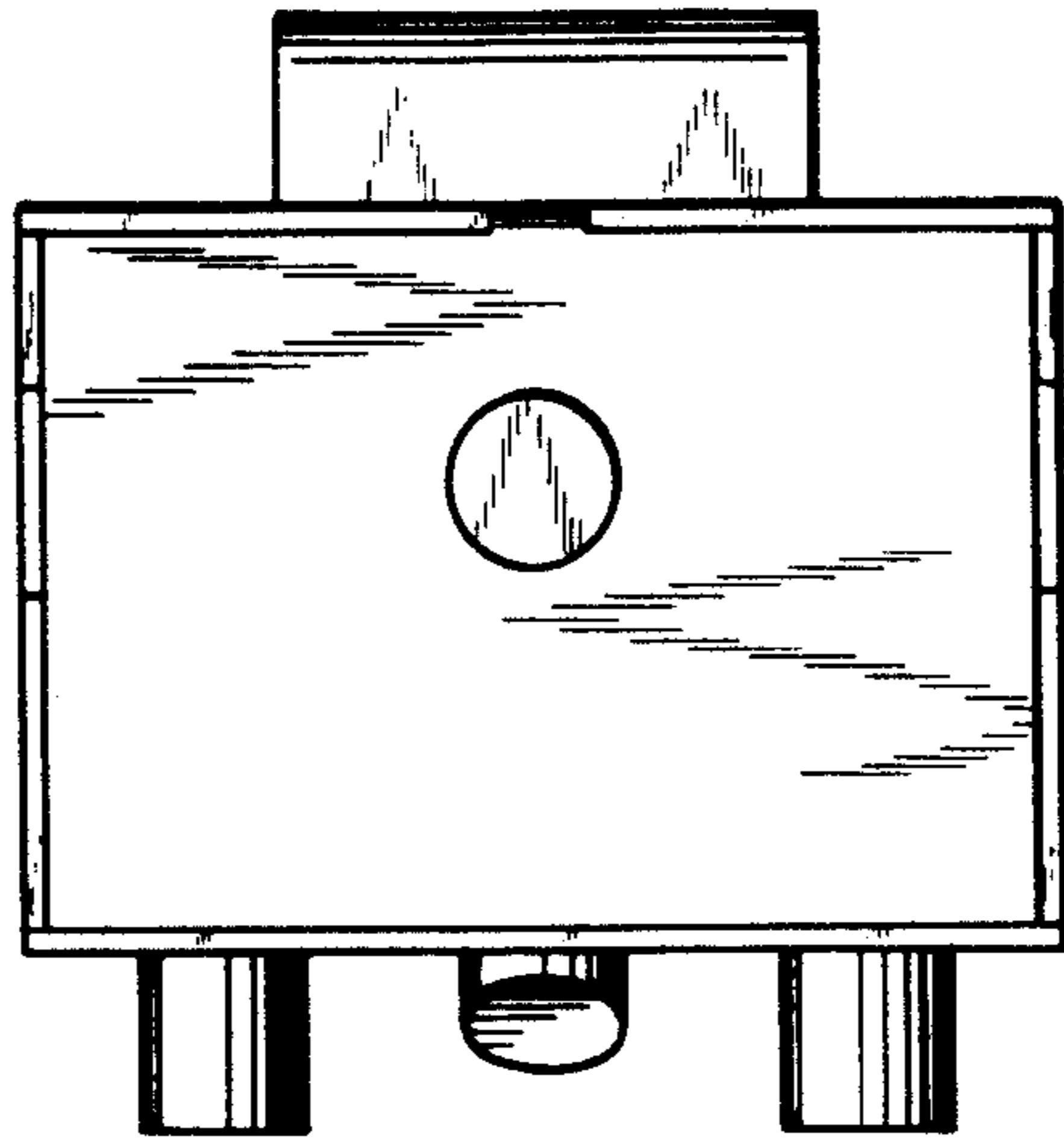

FIG. 8

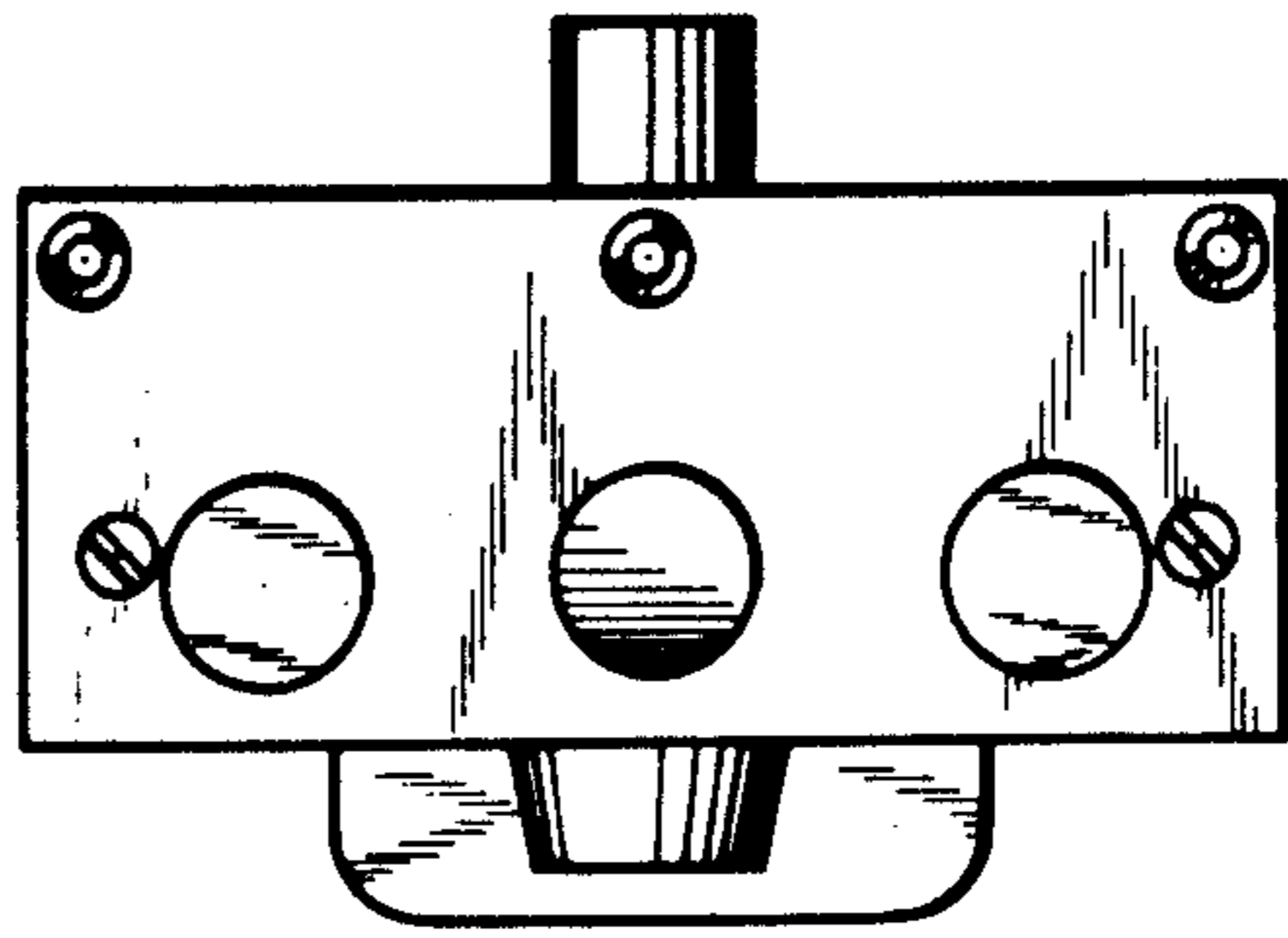

FIG. 7

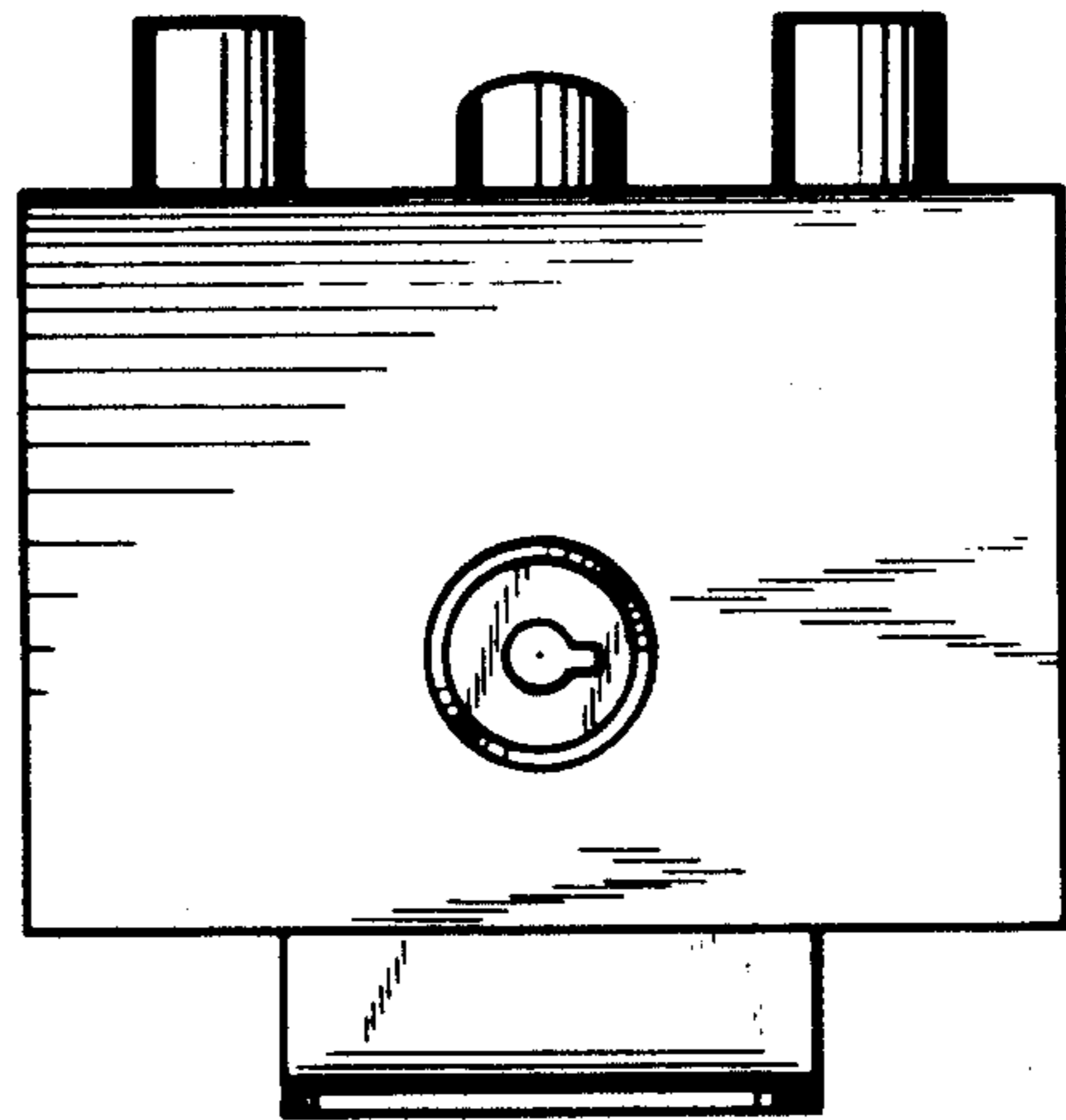

FIG. 6

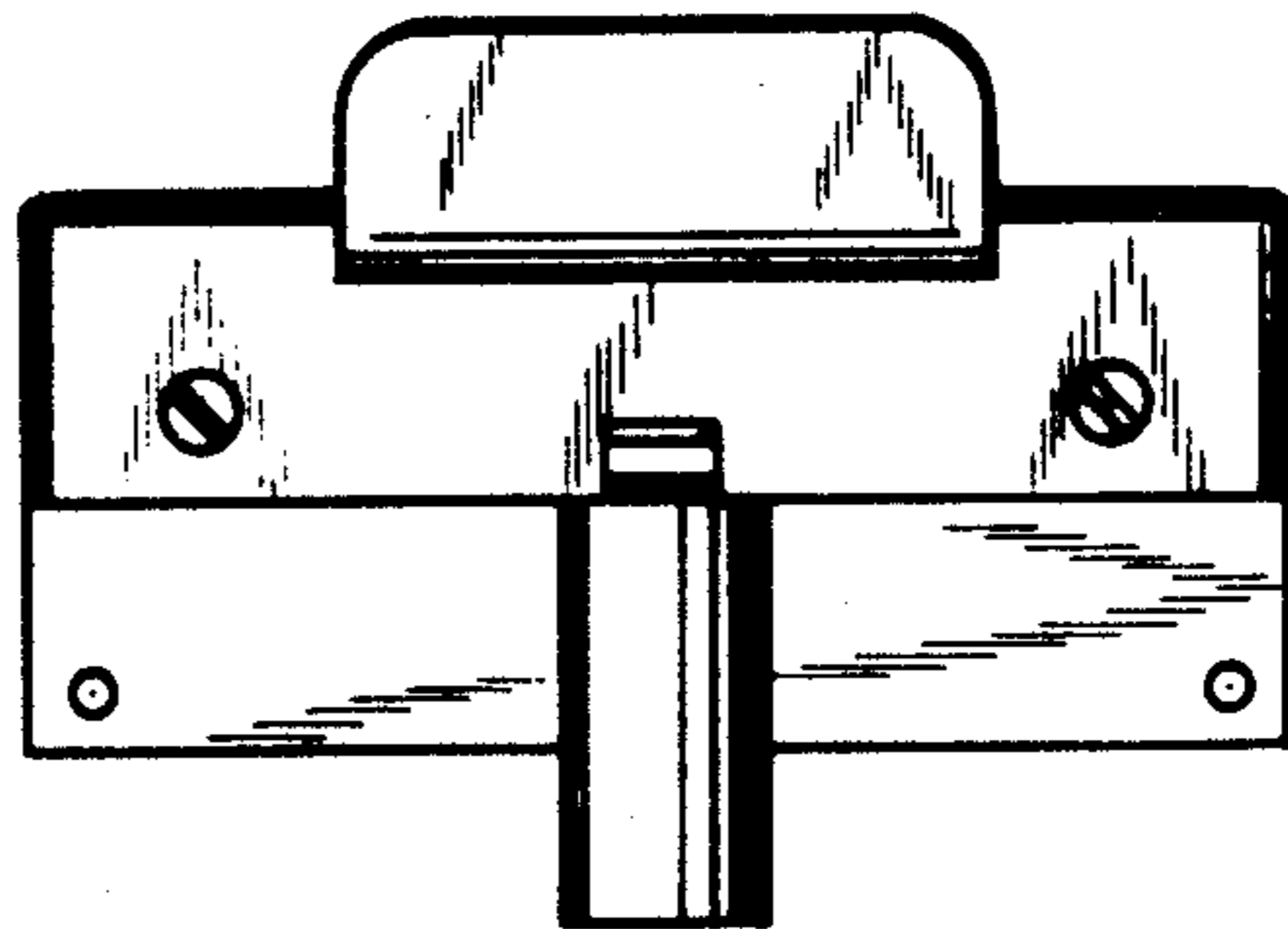

FIG. 10



FIG. 14

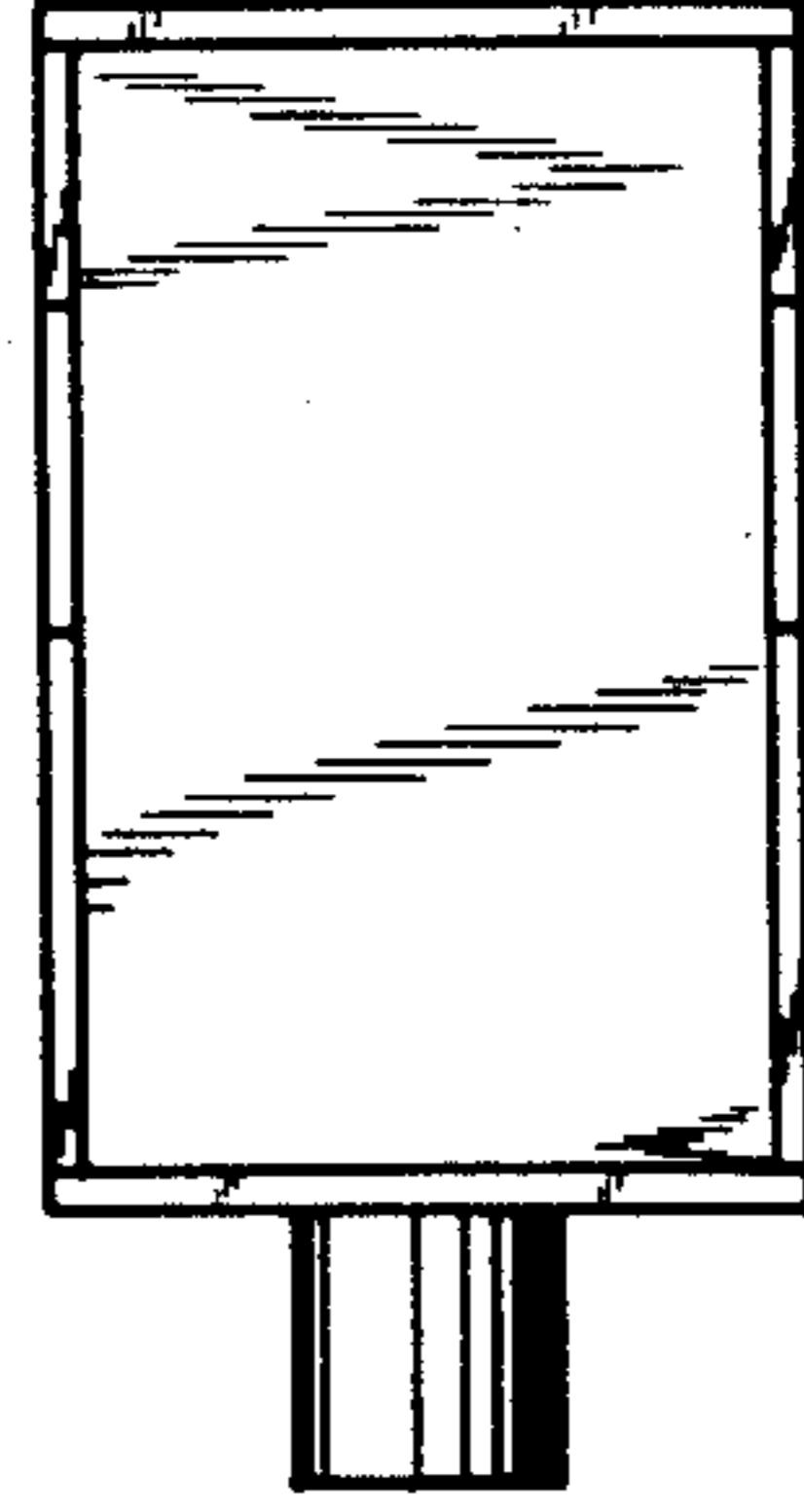

FIG. 13



FIG. 12

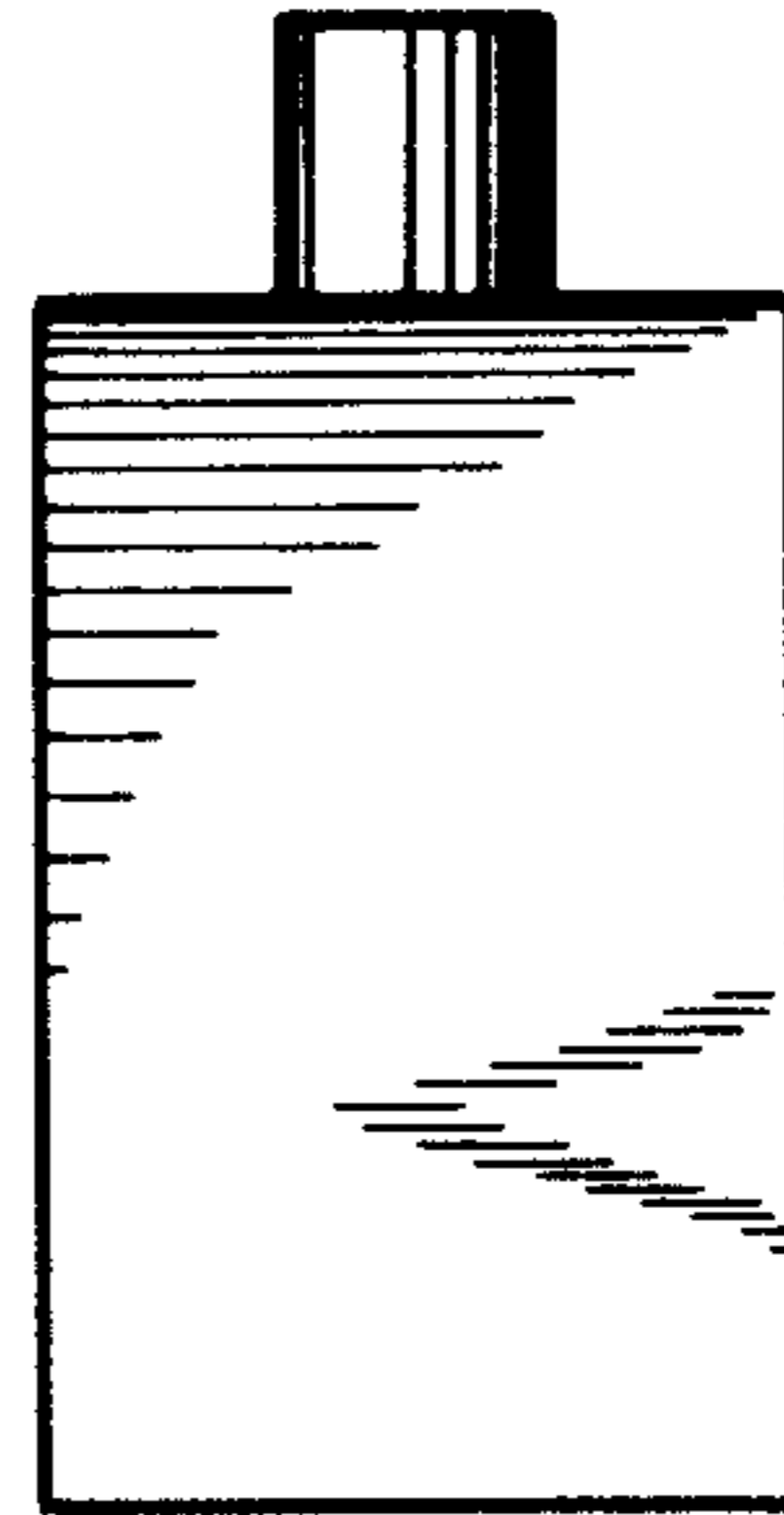

FIG. 11



FIG. 15



FIG. 19



FIG. 18

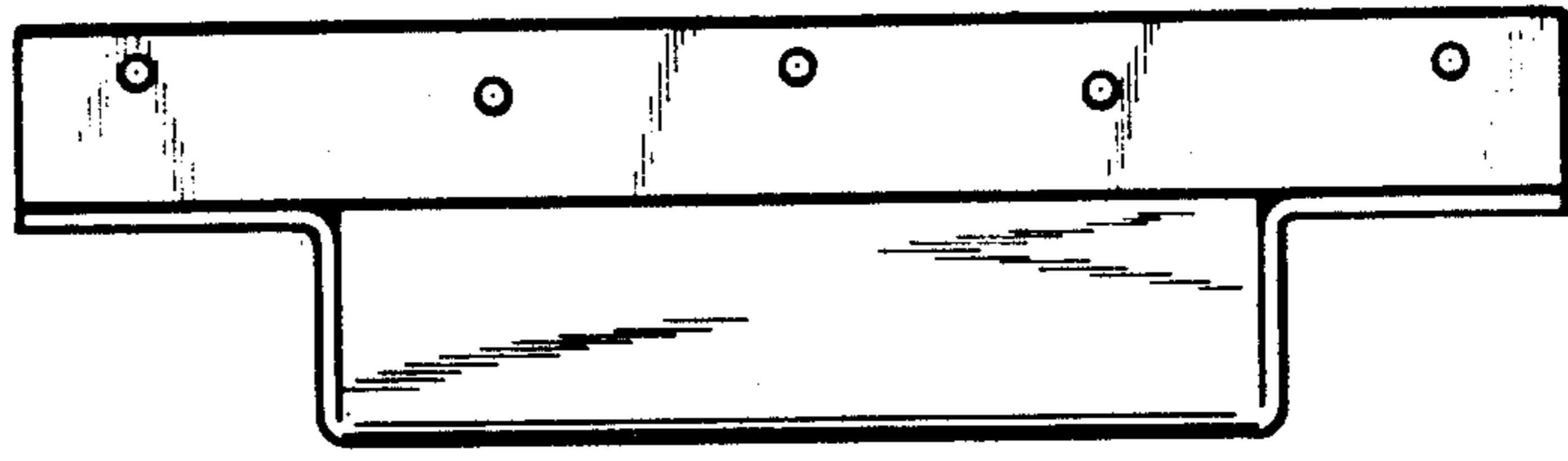

FIG. 17



FIG. 16

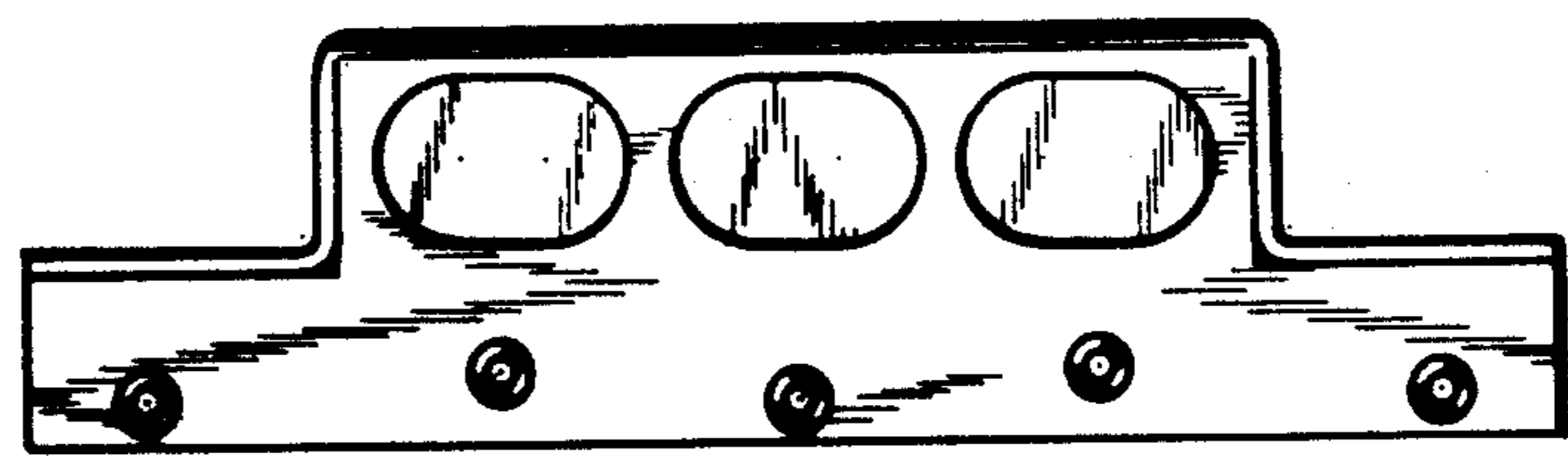

FIG. 20



FIG. 21

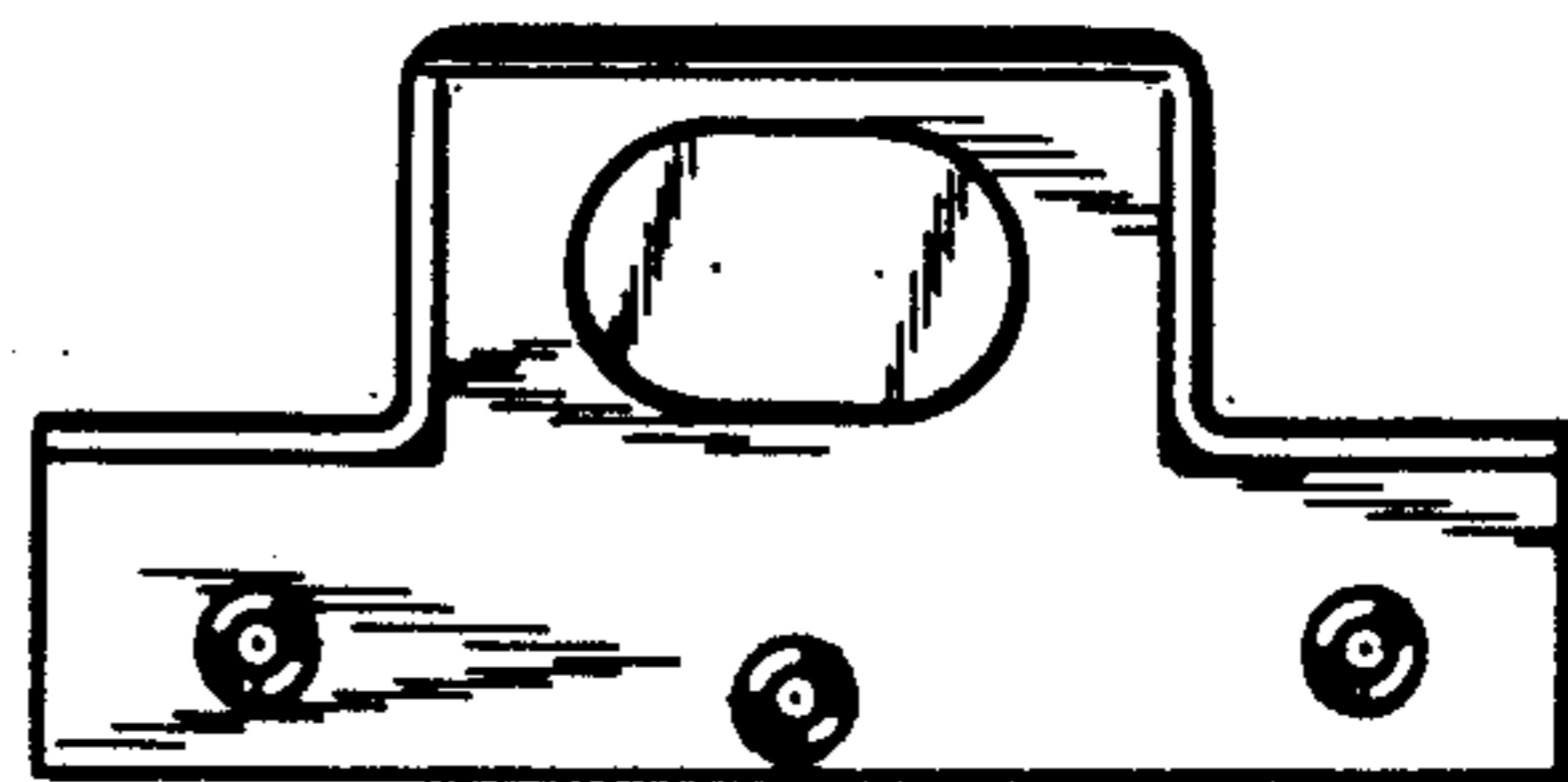

FIG. 22



FIG. 23

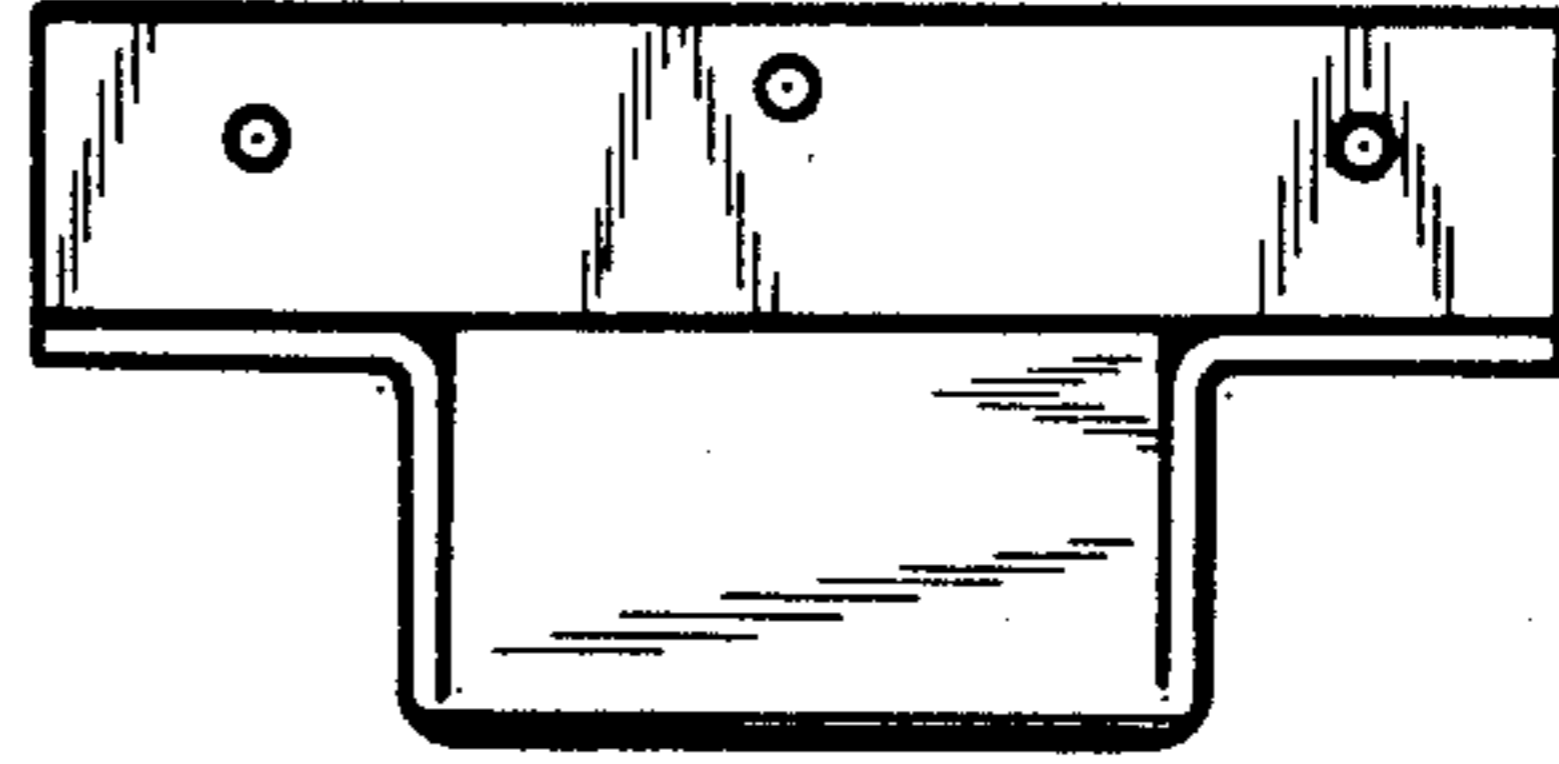

FIG. 24

