

[54] COMBINED AUXILIARY SEAT STORAGE DEVICE AND AUDIO UNIT FOR JEEP TYPE VEHICLE

[76] Inventor: Roger Linto, 366 Newton Dr., Lake Orion, Mich. 48035

[\*\*] Term: 14 Years

[21] Appl. No.: 836,700

[22] Filed: Sep. 26, 1977

[51] Int. Cl. .... D6-01

[52] U.S. Cl. .... D6/48; D6/64; D12/157

[58] Field of Search ..... D12/156, 157, 155; D6/48, 64; 296/37.1, 37.5, 37.15, 1 R; 224/42.42 A; 297/194; 312/235 R

[56] References Cited

U.S. PATENT DOCUMENTS

D. 151,662	11/1948	Smead	.....	D6/64
3,136,578	6/1964	Tihovici	.....	312/235 R
3,159,423	12/1964	Gilbert	.....	312/235 R

FOREIGN PATENT DOCUMENTS

1578491 8/1969 France ..... 296/37.15

OTHER PUBLICATIONS

J. C. Whitney Catalog No. 362B, P40, Rear Seat for Jeep, top center of page.

Primary Examiner—James M. Gandy  
Attorney, Agent, or Firm—William L. Fisher

[57] CLAIM

The ornamental design for a combined auxiliary seat storage device and audio unit for a jeep type vehicle, as shown and described.

DESCRIPTION

FIG. 1 is a perspective view of a combined auxiliary seat, storage device and audio unit for jeep type vehicle showing my new design; the broken line showing of a portion of a jeep type vehicle is for illustrative purposes only.

FIG. 2 is an enlarged top plan view thereof;

FIG. 3 is an enlarged front elevational view thereof;

FIG. 4 is a rear elevational view thereof; and

FIG. 5 is an enlarged side elevational view thereof the opposite side being a mirror image of the side shown.

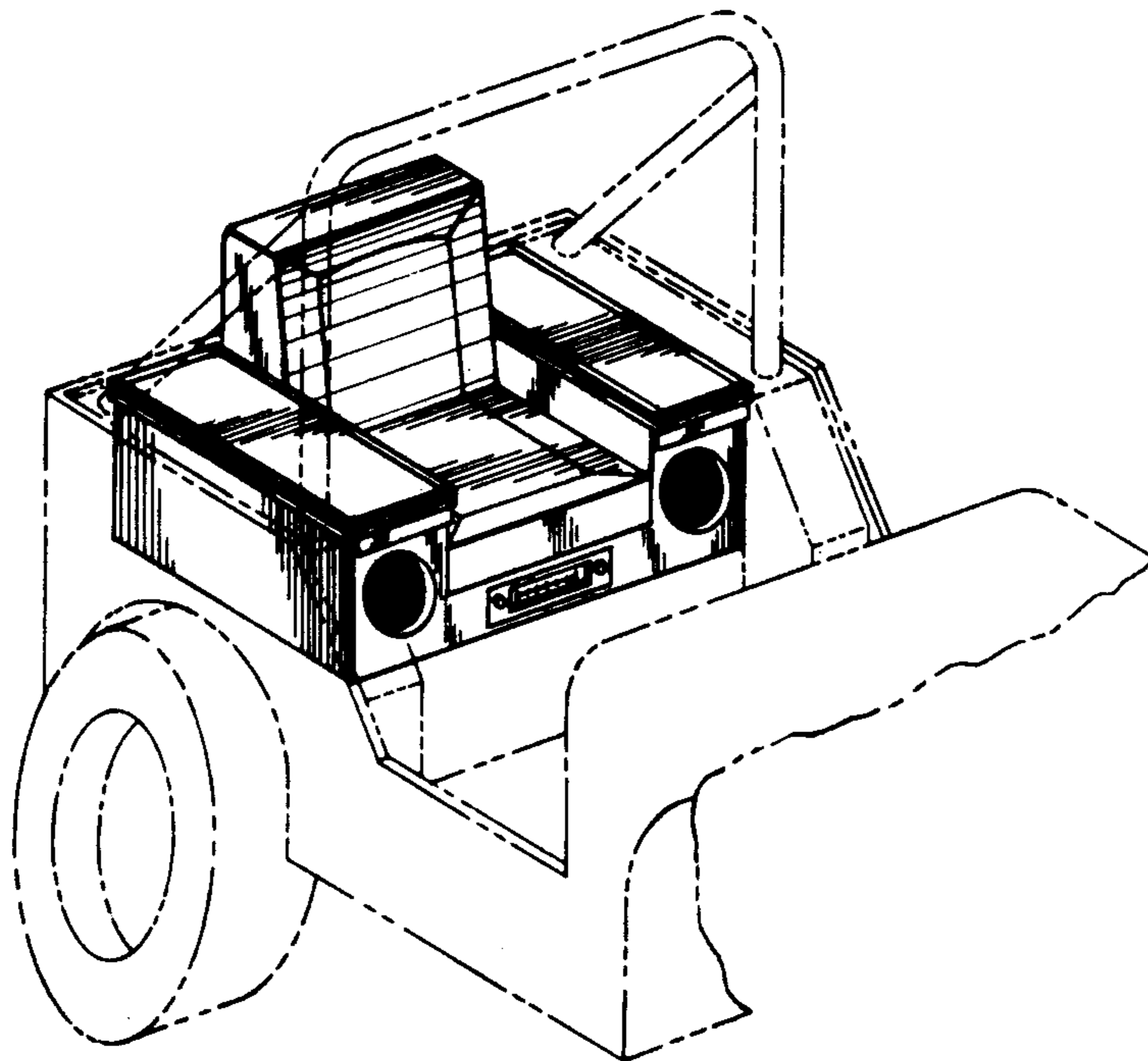

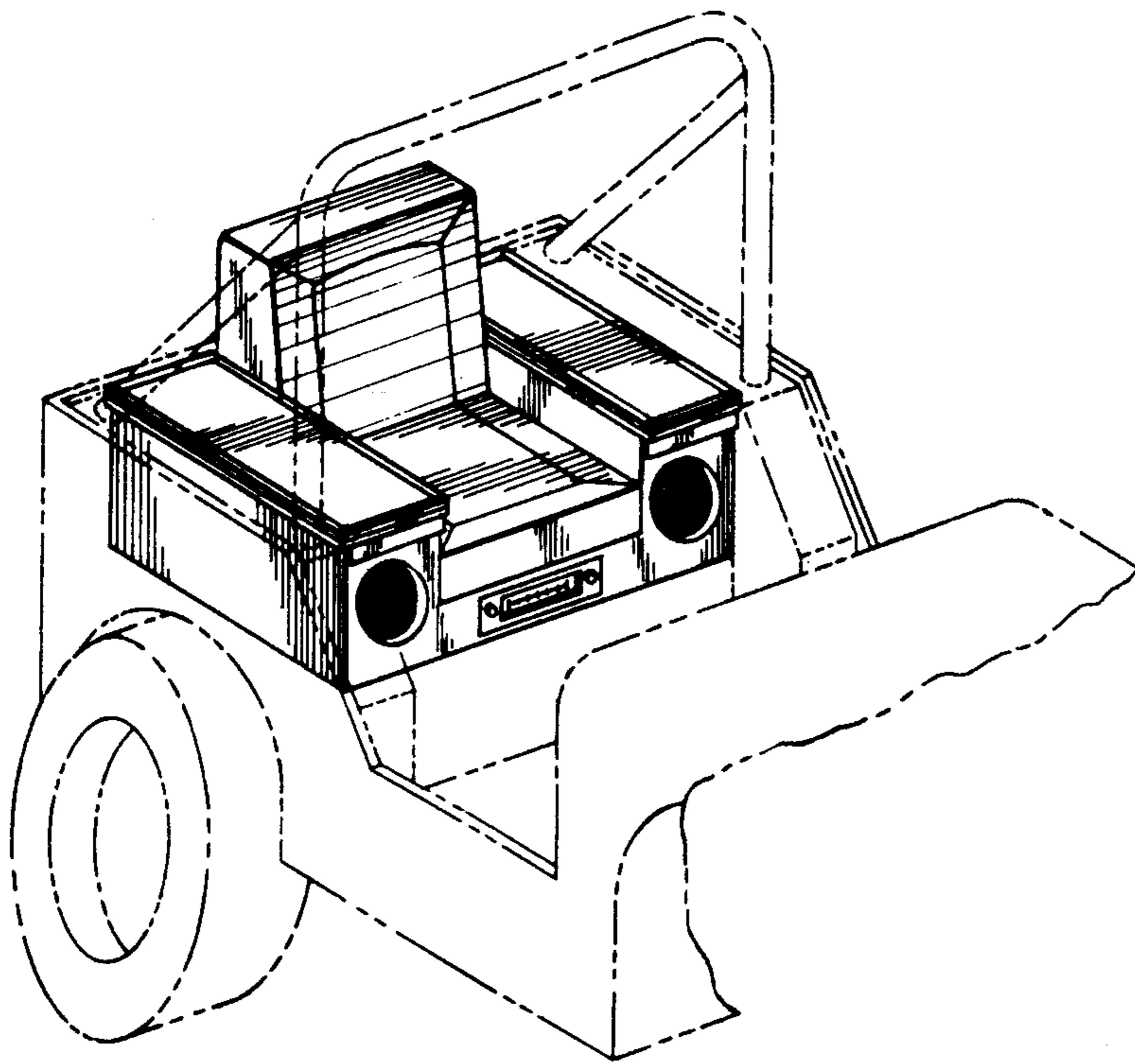

FIG. 1

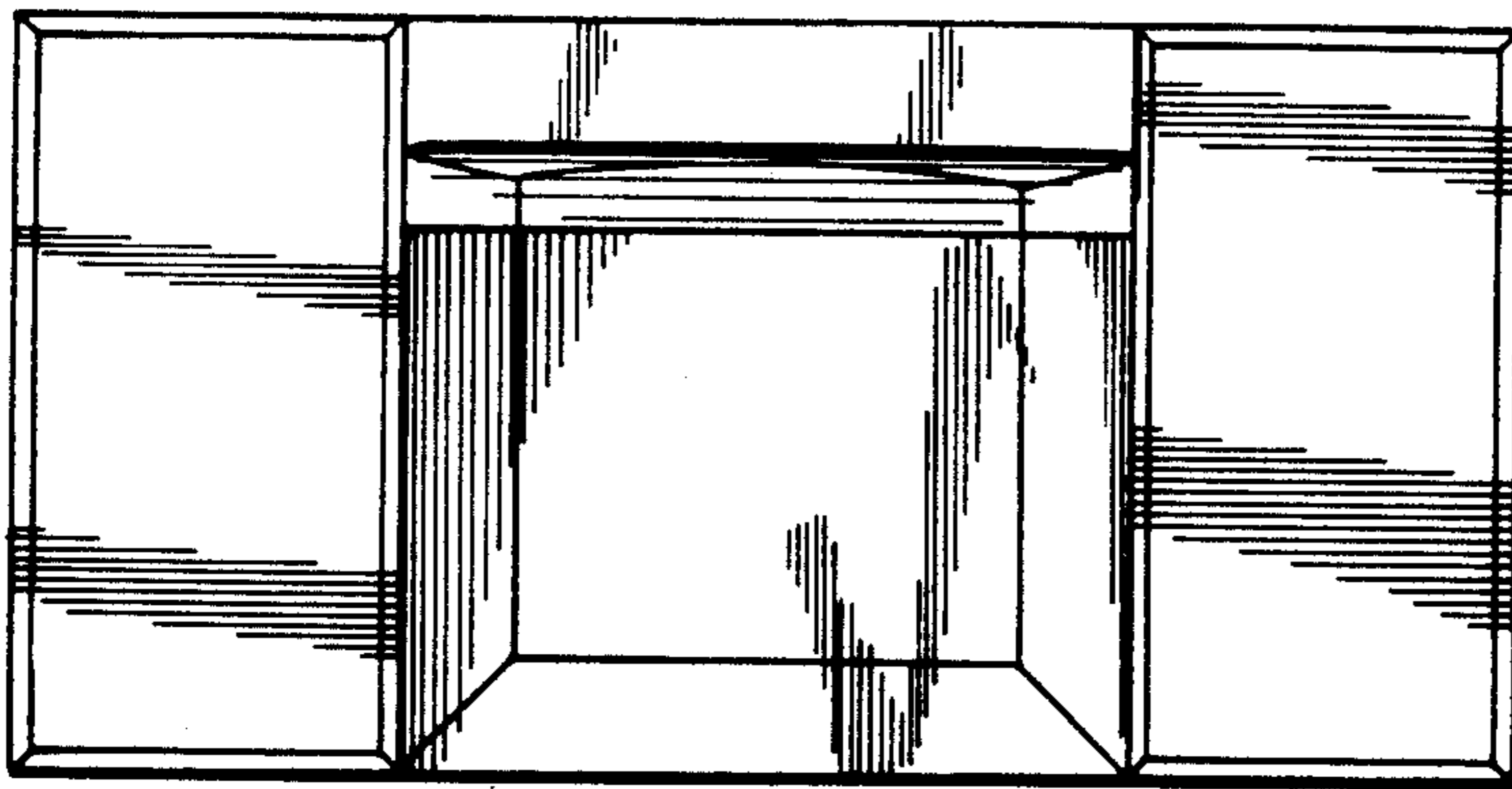

FIG. 2

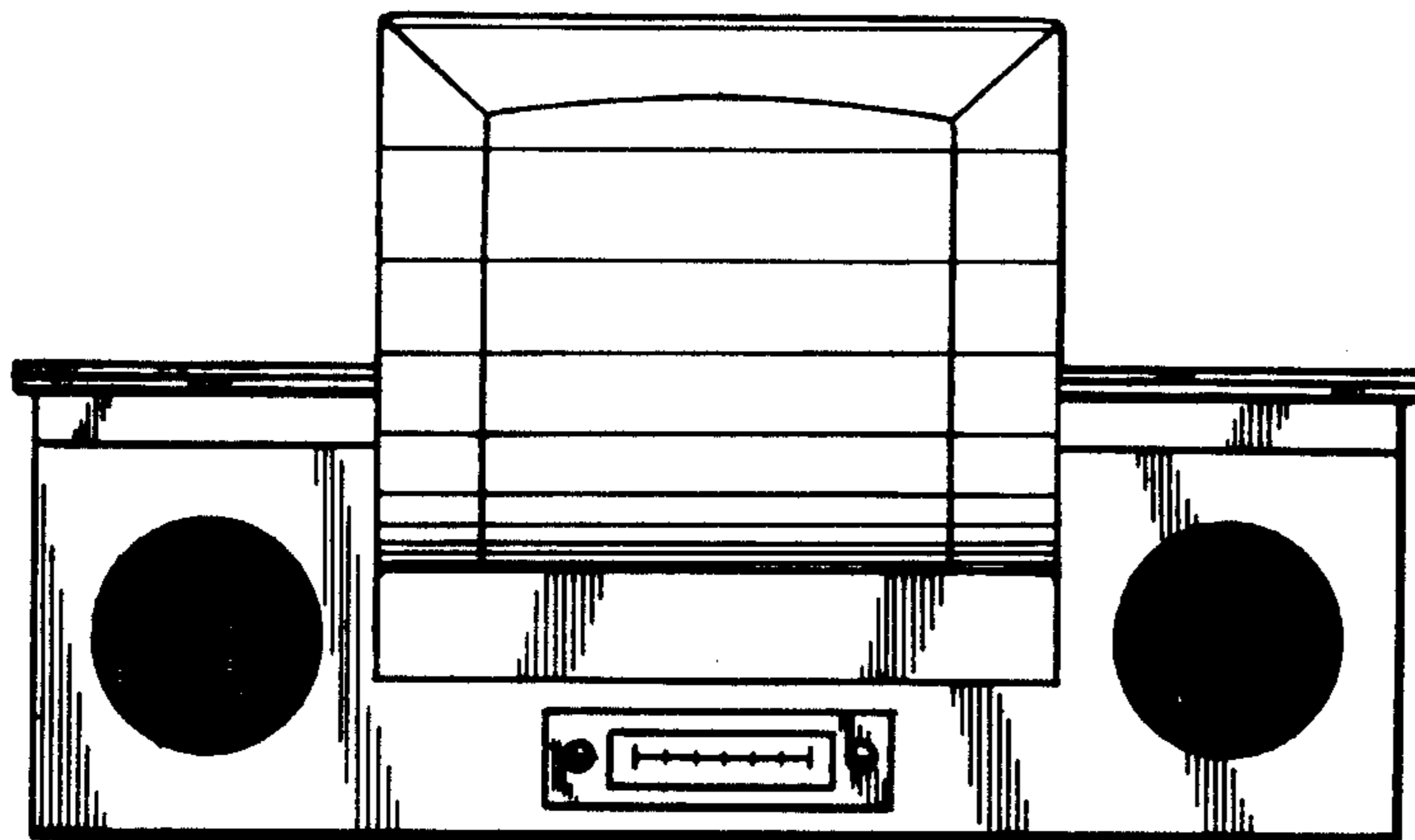

FIG. 3

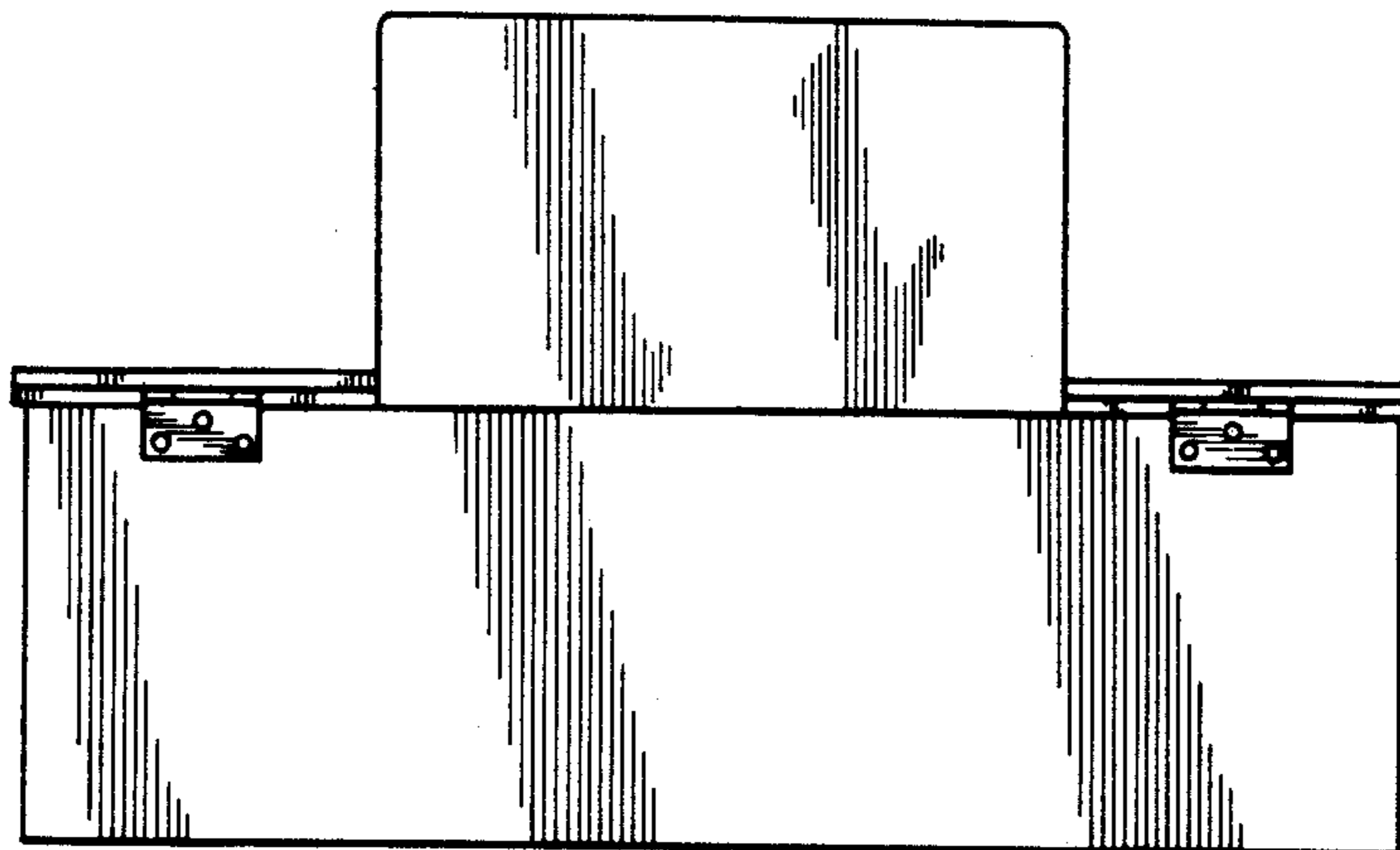

FIG - 4

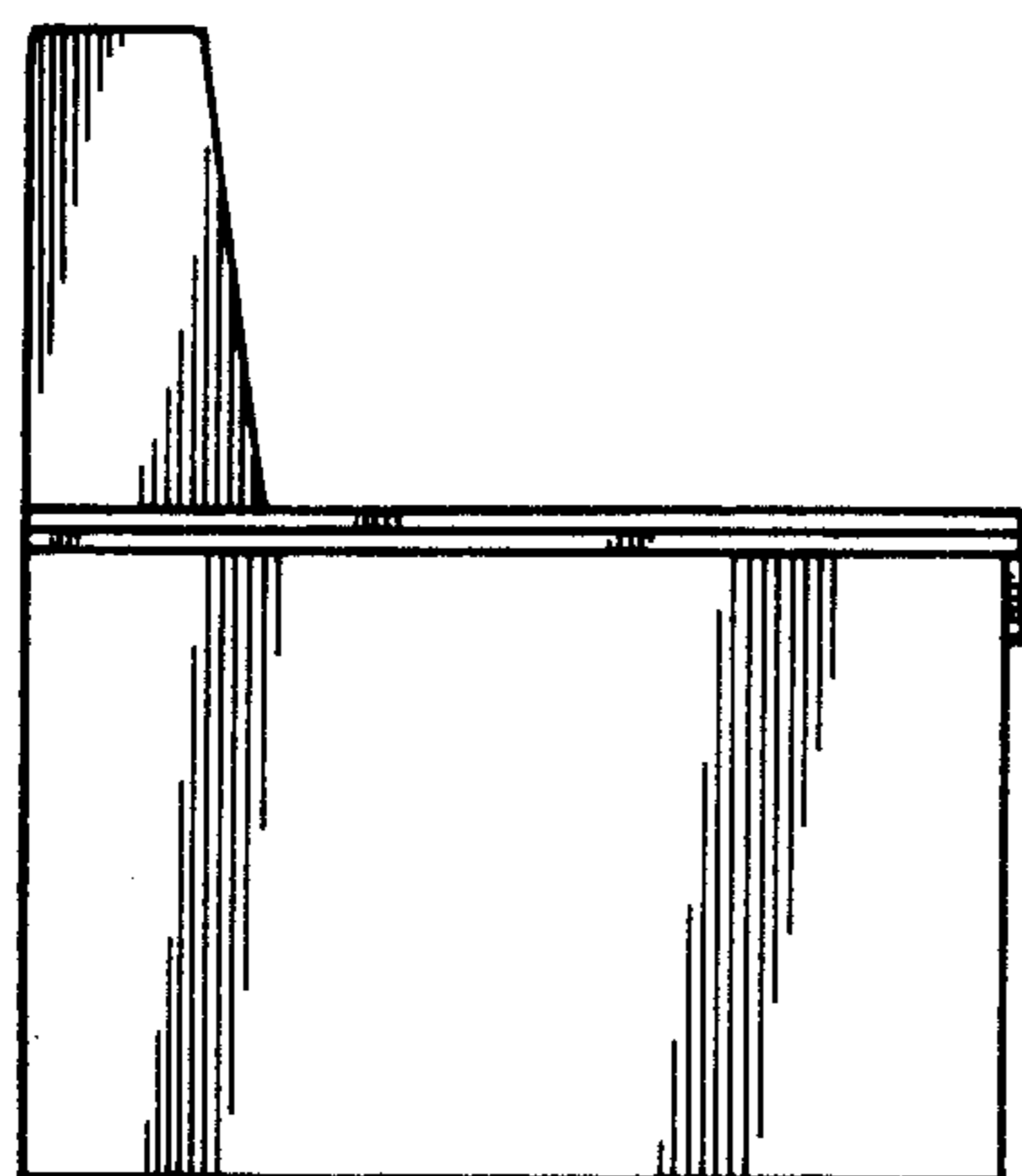

FIG - 5