

[54] MOTORCYCLE

[75] Inventors: Einosuke Miyachi, Urawa; Tsutomu Okuno, Fujimi, both of Japan

[73] Assignee: Honda Giken Kogyo Kabushiki Kaisha, Tokyo, Japan

[**] Term: 14 Years

[21] Appl. No.: 885,028

[22] Filed: Mar. 8, 1978

[30] Foreign Application Priority Data

Sep. 13, 1977 [JP] Japan 52-36532

[51] Int. Cl. D12-11

[52] U.S. Cl. D12/110

[58] Field of Search D12/110; 180/33 R

[56]

References Cited

PUBLICATIONS

Yamaha RD350 Motorcycle Brochure, 350 Motorcycle on inside of front cover.

Cycle, 6/76, p. 95, Yamaha XS500, bottom of page.

Primary Examiner—James M. Gandy

Attorney, Agent, or Firm—Hazeltine, Lake & Waters

[57]

CLAIM

The ornamental design for a motorcycle, as shown.

DESCRIPTION

FIG. 1 is a top plan view of our new design for a motorcycle;

FIG. 2 is a right side elevational view thereof;

FIG. 3 is an enlarged front perspective view thereof;

FIG. 4 is a left side elevational view thereof;

FIG. 5 is an enlarged rear perspective view thereof; and

FIG. 6 is a bottom plan view thereof.

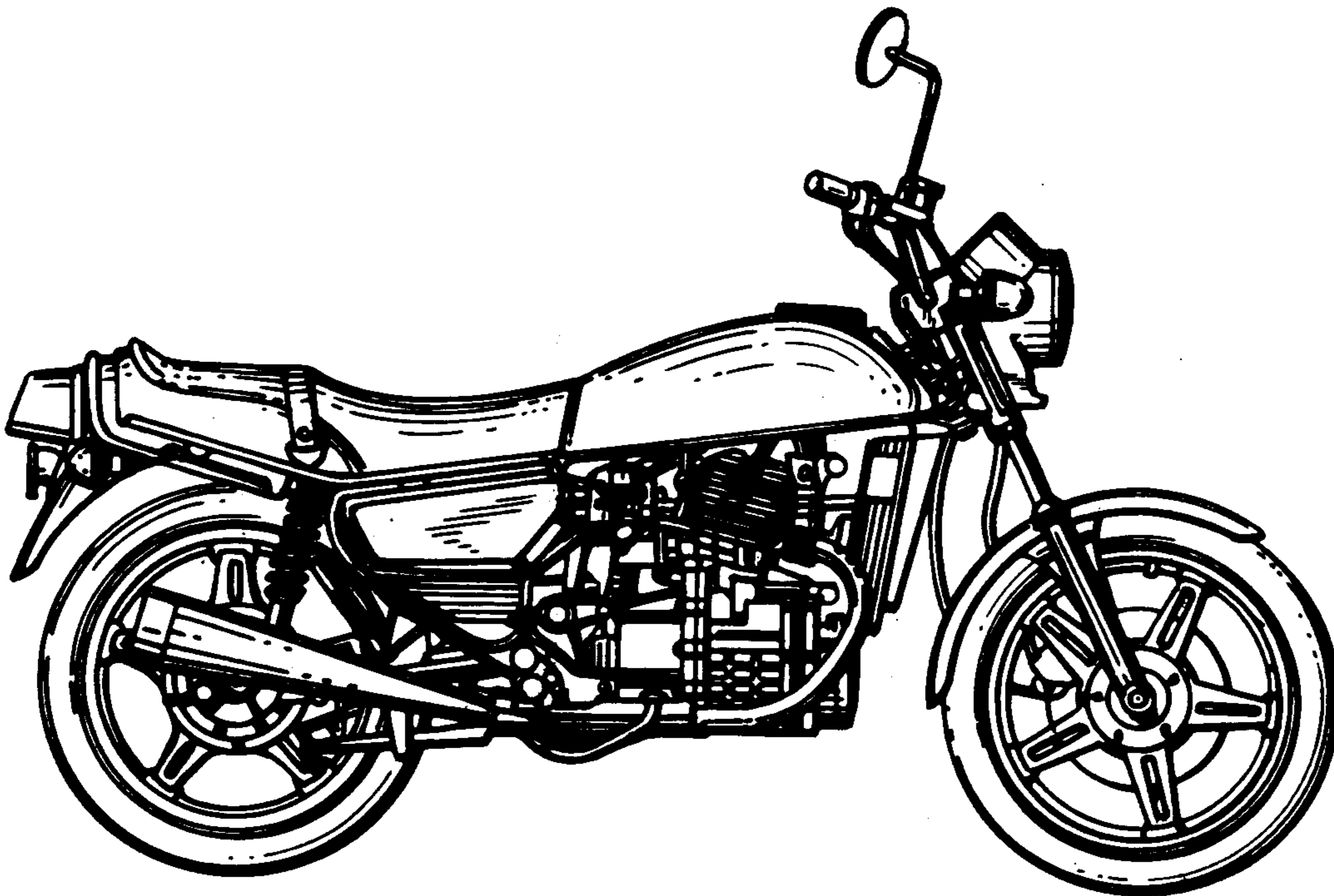

FIG. 1

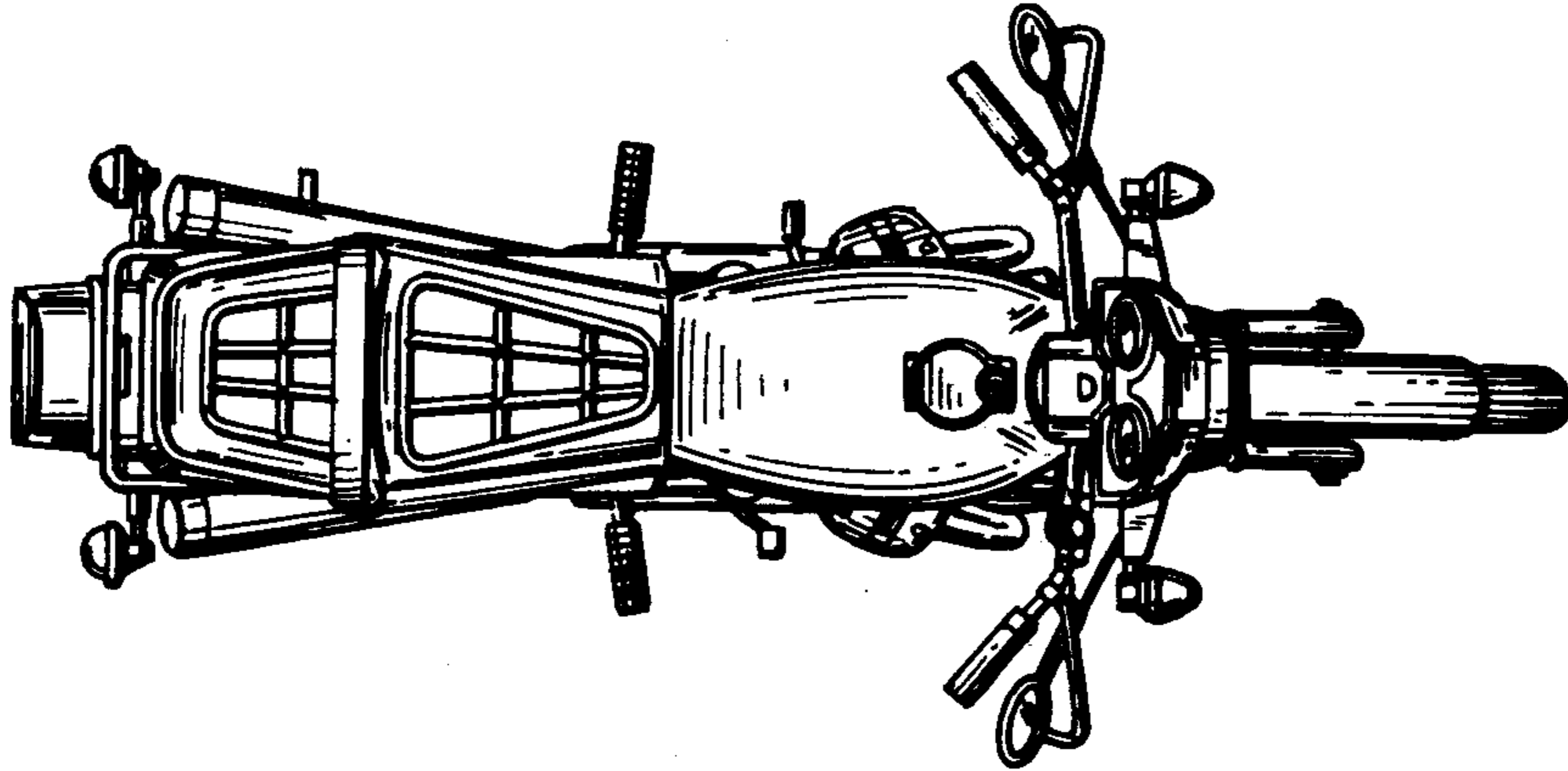

FIG. 2

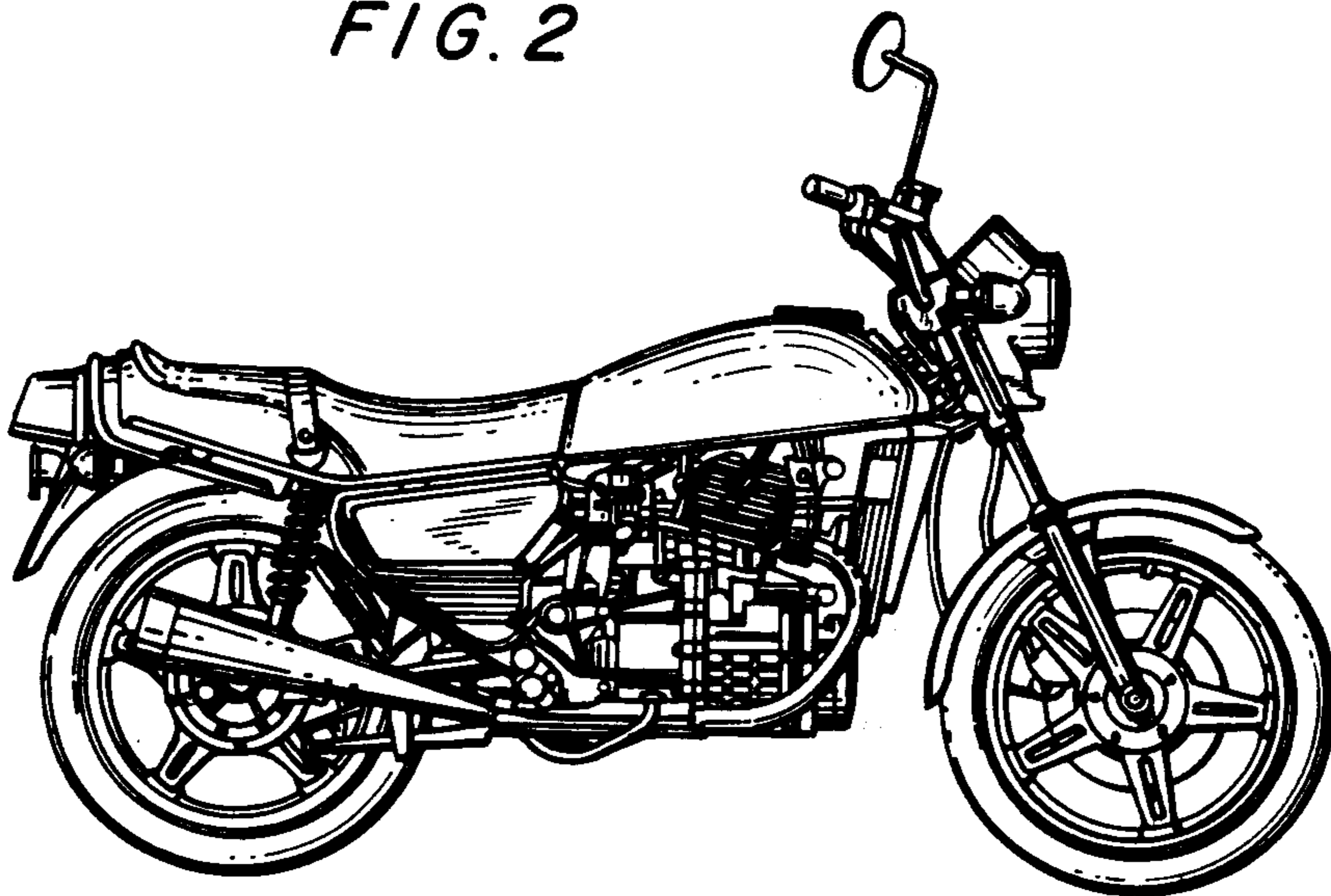

FIG. 3

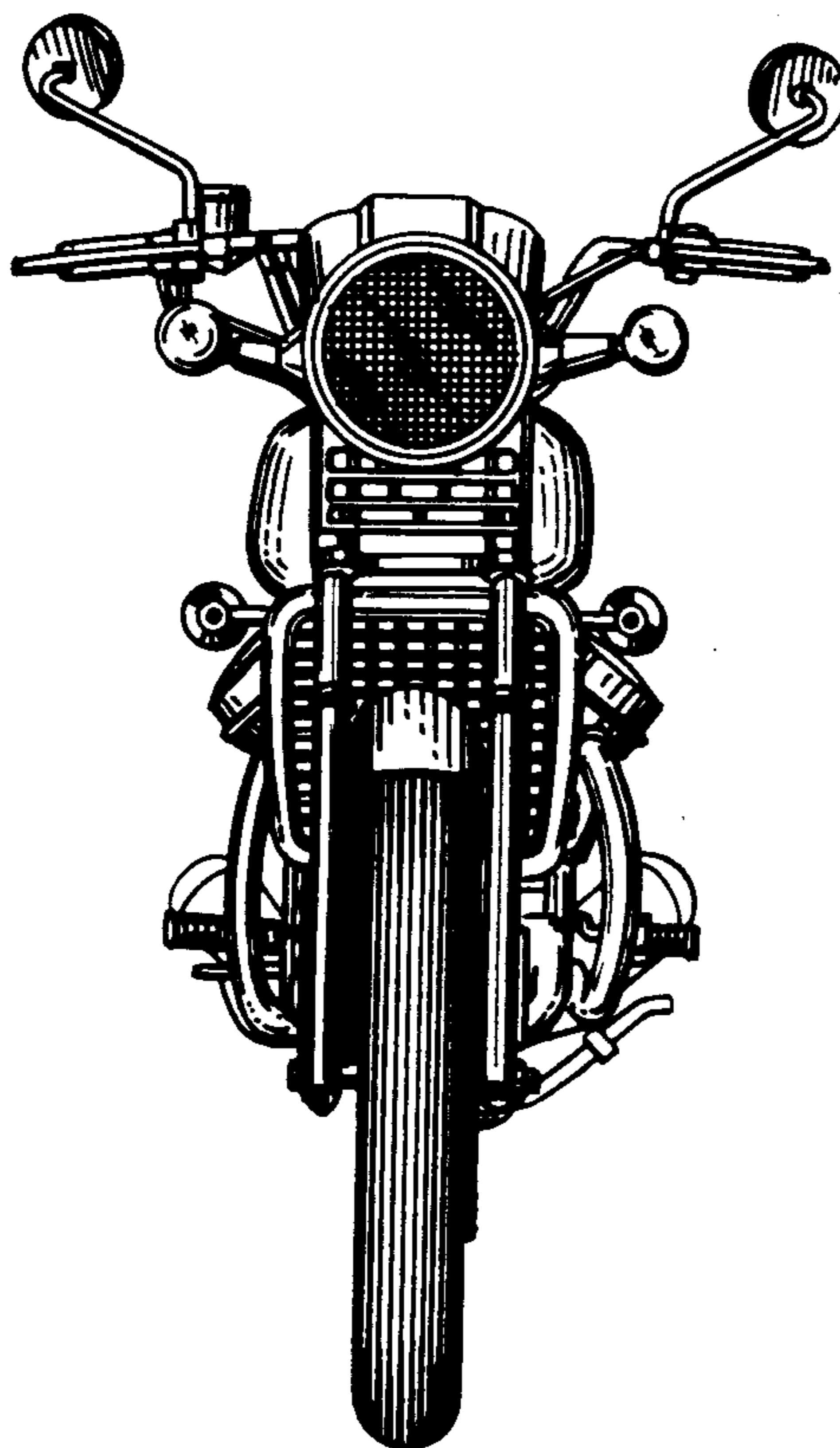

FIG. 4

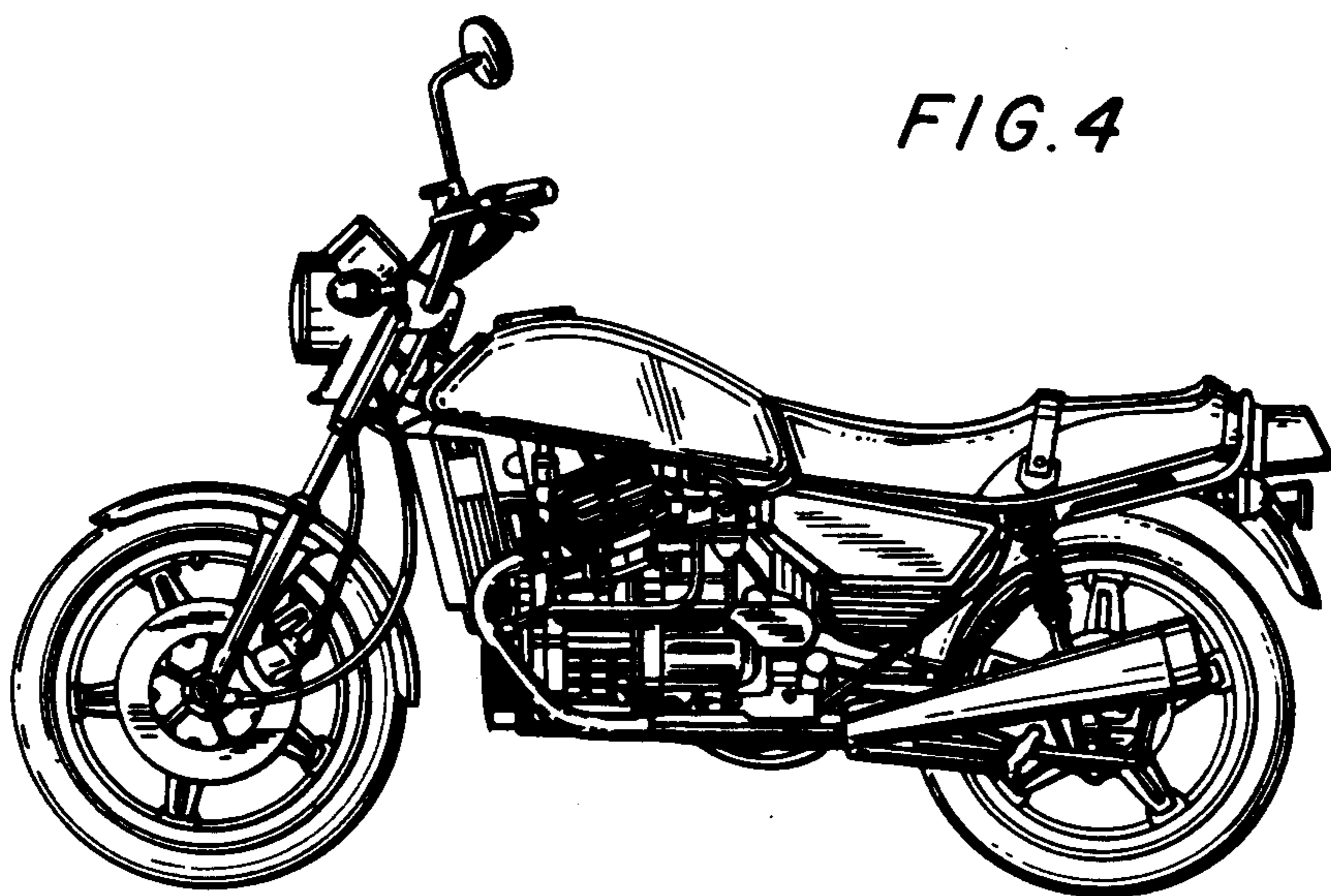

FIG. 5

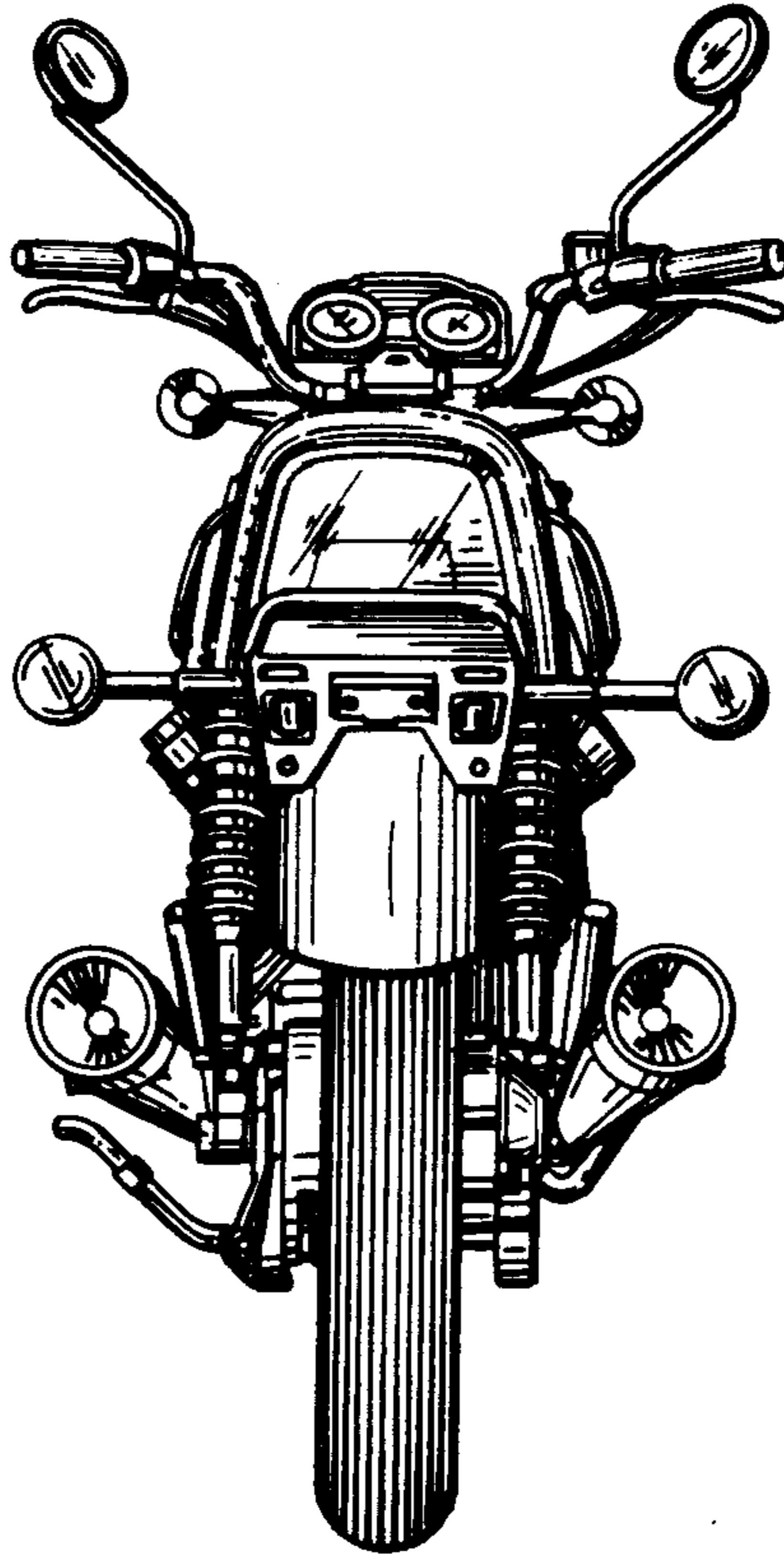

FIG. 6

