

[54] TRAILER LOADING RAMP

[75] Inventor: Jack E. Moll, New Berlin, Wis.

[73] Assignee: Miller Tilt-Top Trailer, Inc., Milwaukee, Wis.

[**] Term: 14 Years

[21] Appl. No.: 812,005

[22] Filed: Jun. 30, 1977

[51] Int. Cl. D12-05

[52] U.S. Cl. D12/53

[58] Field of Search D12/53; 14/71.1, 71.3, 14/71.5; 214/85; 296/61; 254/88

[56] References Cited

U.S. PATENT DOCUMENTS

3,516,560 6/1970 Brighton 214/85
4,003,483 1/1977 Fulton 214/85

Primary Examiner—James M. Gandy
Attorney, Agent, or Firm—Michael, Best & Friedrich

[57] CLAIM

The ornamental design for a trailer loading ramp, as shown and described.

DESCRIPTION

FIG. 1 is a perspective view of a trailer loading ramp showing my new design;
FIG. 2 is a top plan view thereof;
FIG. 3 is a rear end elevation view thereof;
FIG. 4 is a bottom plan view thereof; and
FIG. 5 is a front end elevation view thereof.
The side opposite to that shown in FIG. 1 is substantially a mirror image there of.

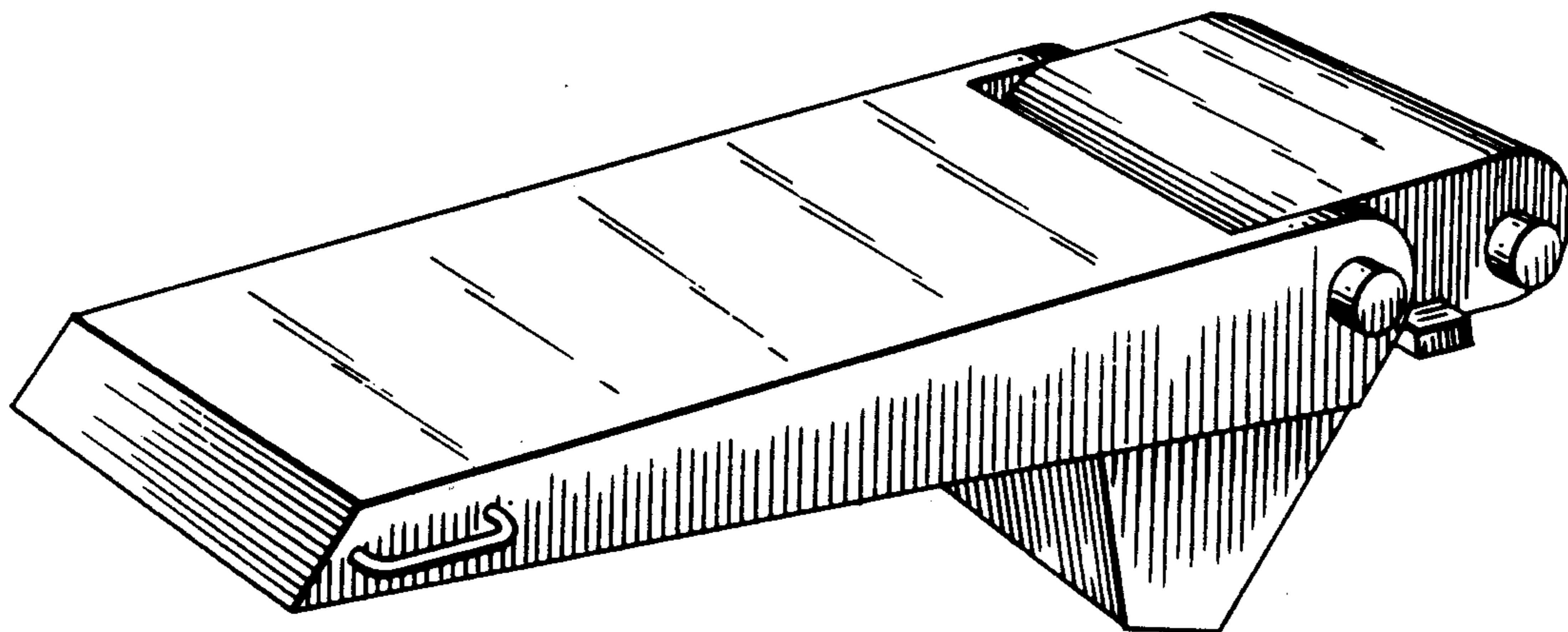

Fig. 1

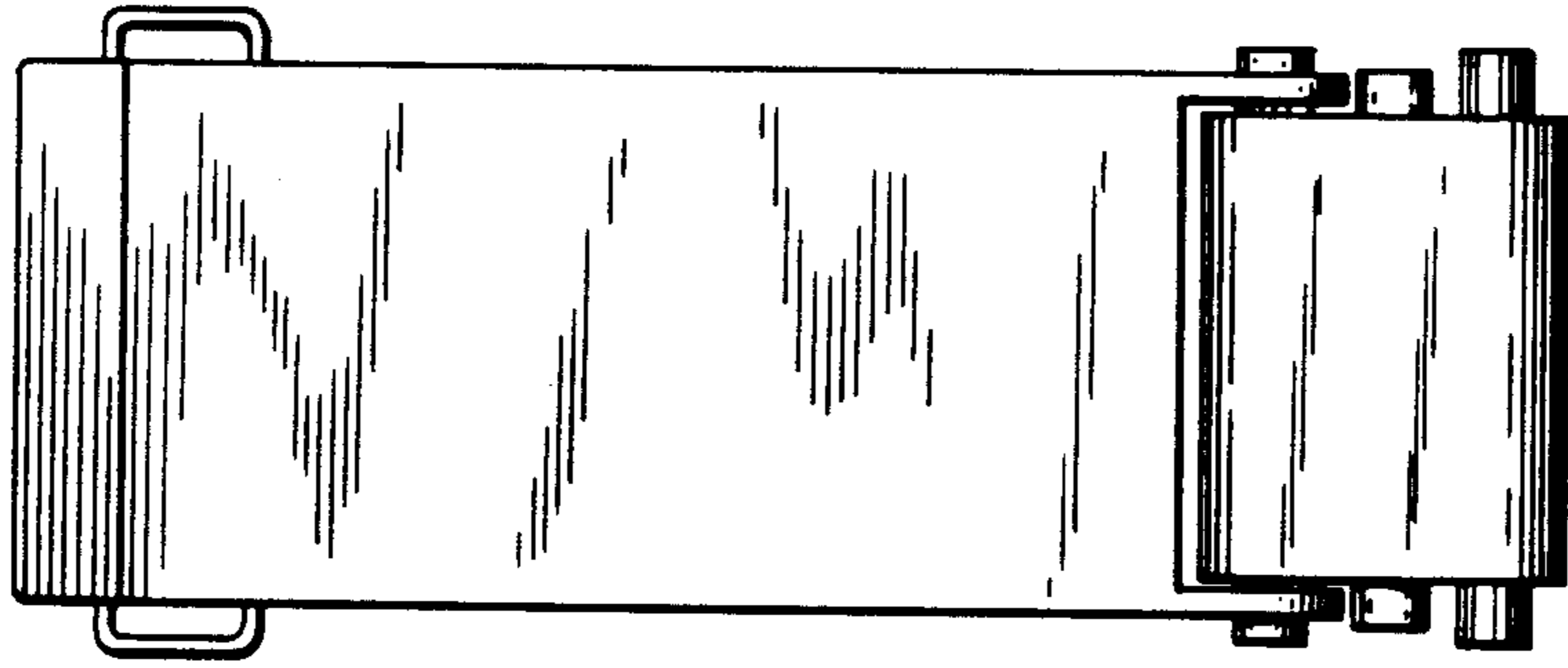
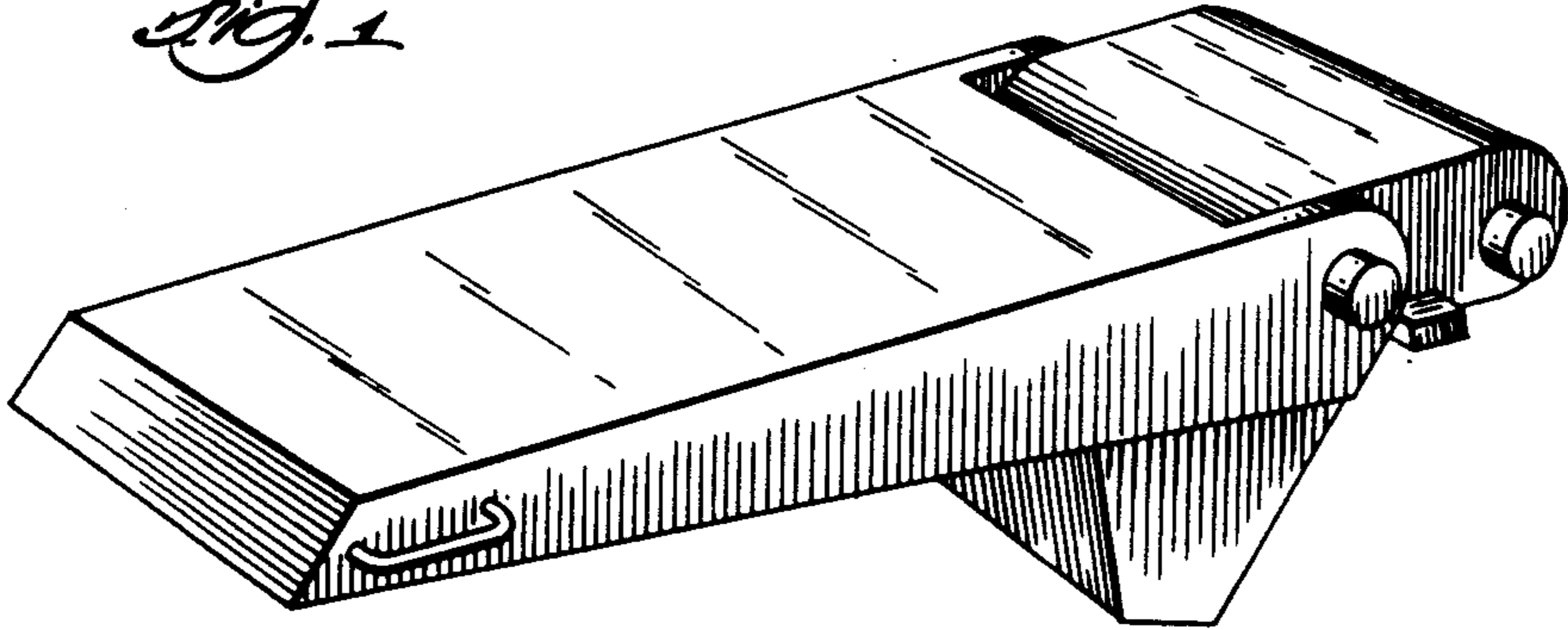

Fig. 2.

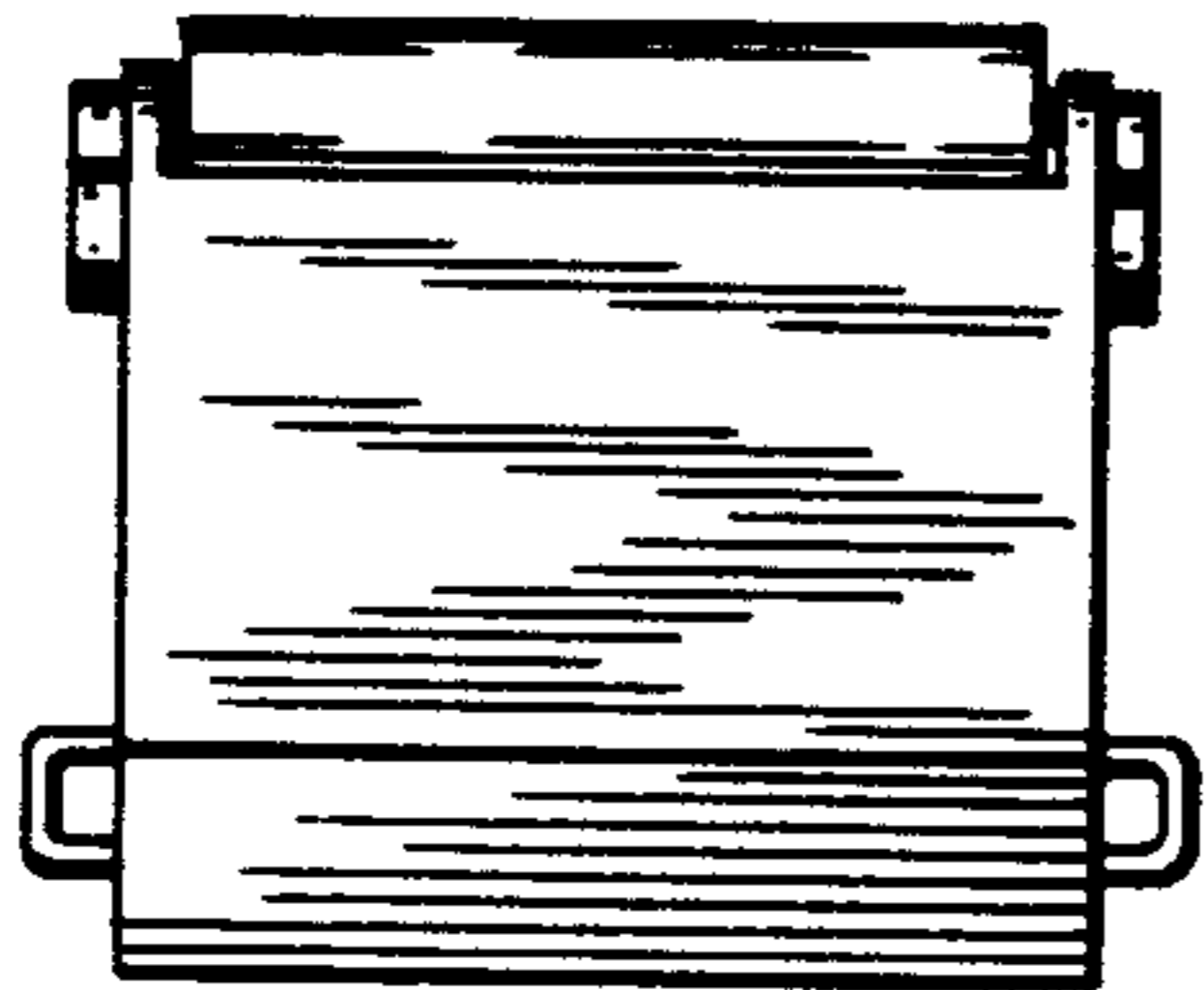

Fig. 3

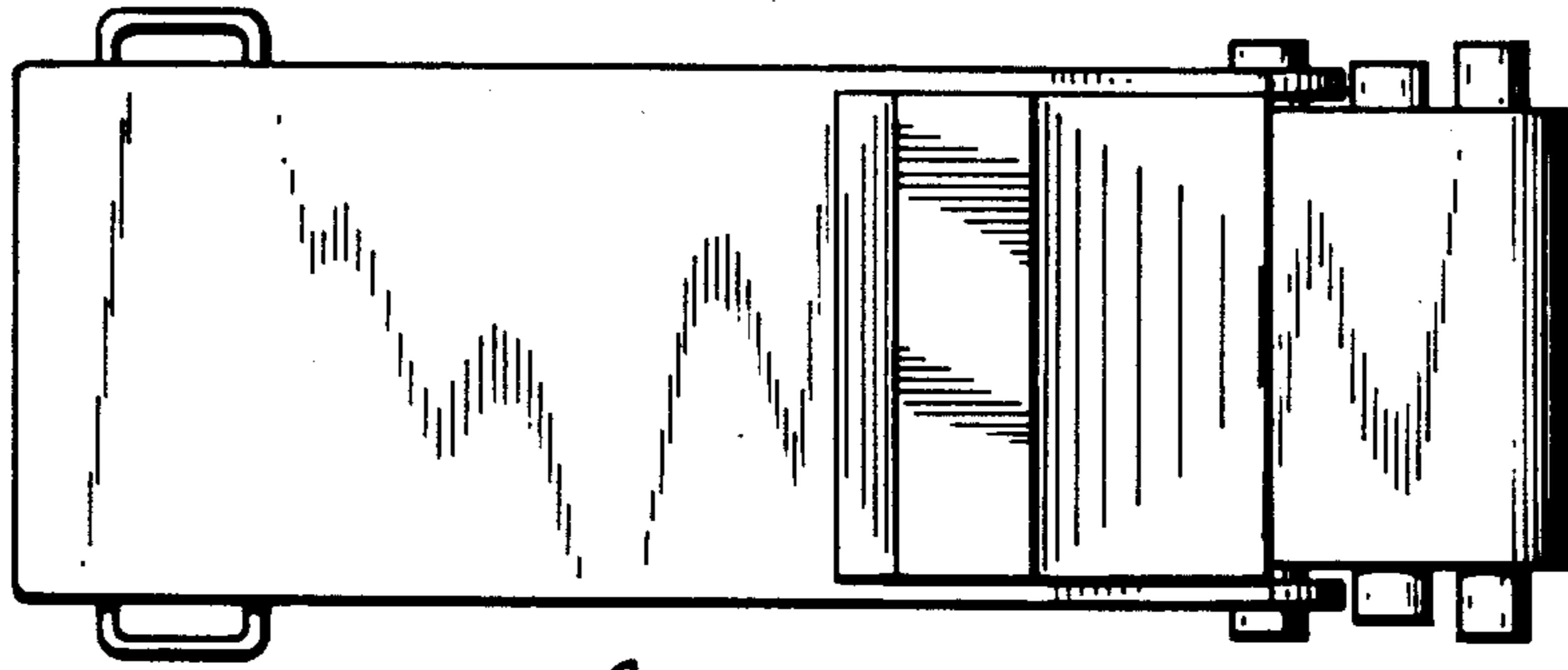

Fig. 4

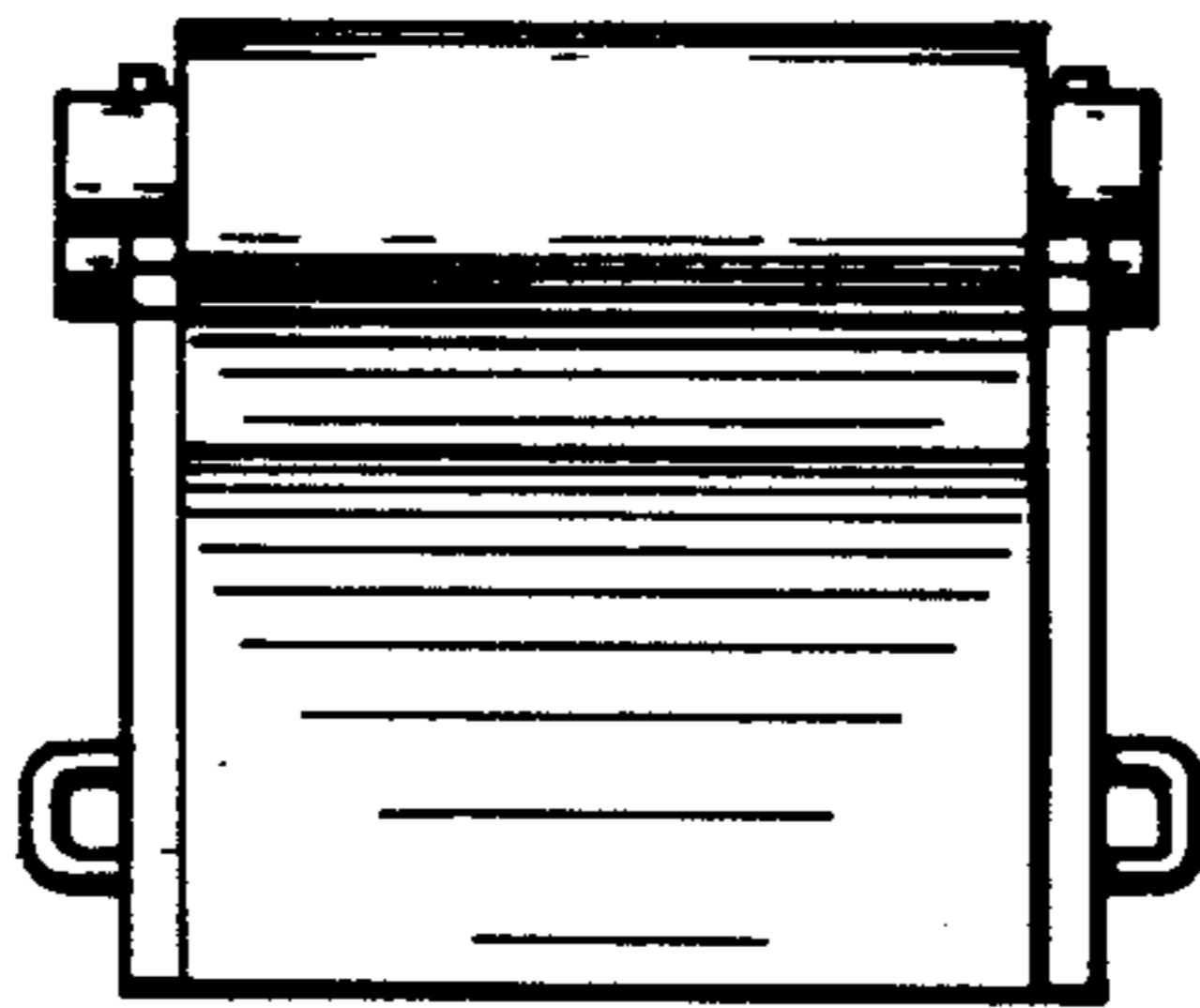

Fig. 5