

[54] DEBRIS RECEPTACLE

[76] Inventor: **Hugh O. Daniel**, 3136 Birdsall Ave., Oakland, Calif. 94619

[**] Term: **14 Years**

[21] Appl. No.: **793,079**

[22] Filed: **May 2, 1977**

[51] Int. Cl. **D7-05**

[52] U.S. Cl. **D7/186**

[58] Field of Search **D7/186; 15/257.1, 257.2, 15/257.9; 220/20; 294/49, 55, 57, 58, 59, 54**

[56] **References Cited**

U.S. PATENT DOCUMENTS

D. 208,969	10/1967	Paxton	D64/18
3,132,735	5/1964	Nilsen	294/55 XV
3,380,101	4/1968	Phillips	15/257.1
3,923,331	12/1975	Hollnagel	294/54

FOREIGN PATENT DOCUMENTS

421664	2/1911	France	15/257.9
--------	--------	--------------	----------

804459 4/1951 Fed. Rep. of Germany 294/55

Primary Examiner—Bernard Ansher
Assistant Examiner—Catherine Kemper
Attorney, Agent, or Firm—George W. Wasson

[57] **CLAIM**

The ornamental design for a debris receptacle, substantially as shown and described.

DESCRIPTION

FIG. 1 is a perspective view of the debris receptacle showing my new design;

FIG. 2 is a top plan view thereof shown on a smaller scale;

FIG. 3 is a bottom plan view thereof;

FIG. 4 is a side elevational view thereof;

FIG. 5 is a front elevational view thereof;

FIG. 6 is a rear elevational view thereof;

FIG. 7 is a sectional view thereof taken along the lines 7-7 of FIG. 2 and shown on the same scale as FIG. 1.

The characteristic feature of my design resides in the specific appearance of the handle element and its relationship to the body portion of the receptacle, as is best shown in FIGS. 1, 4, and 6.

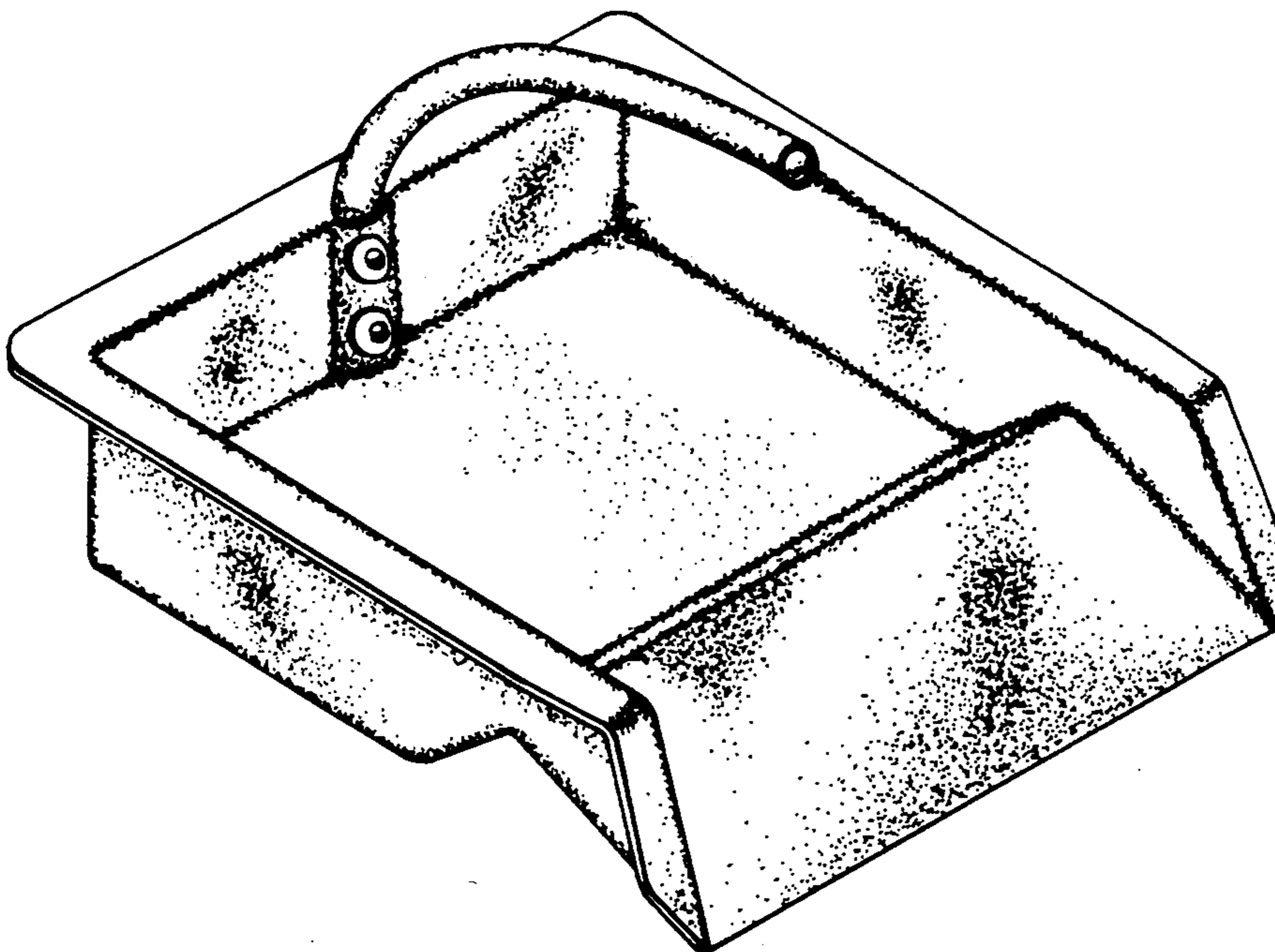

FIG _ 1

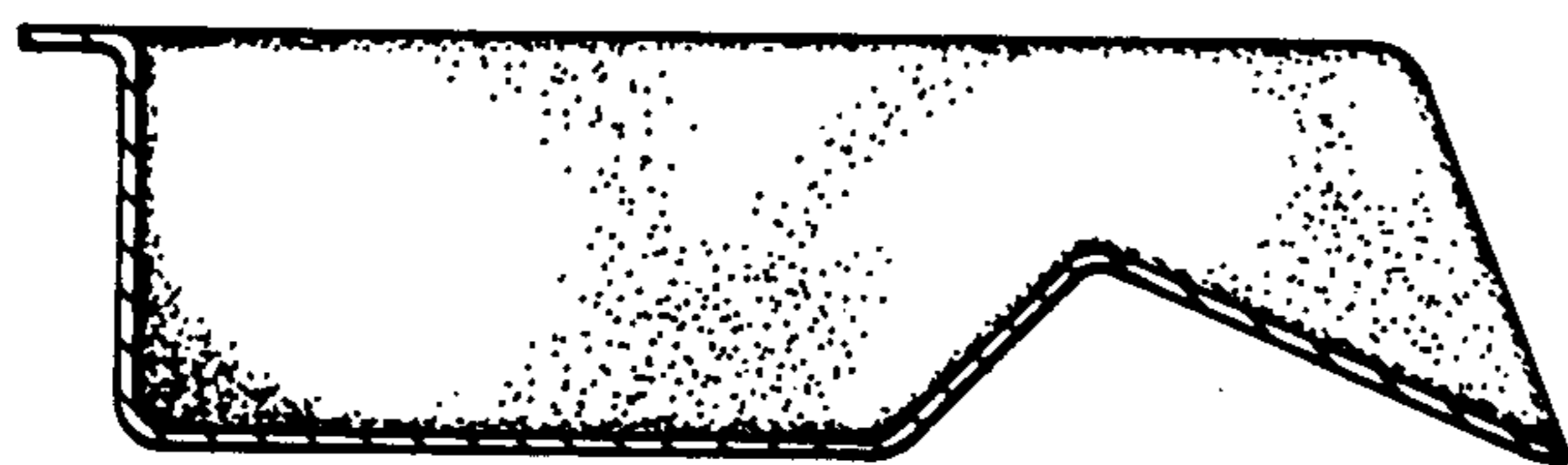
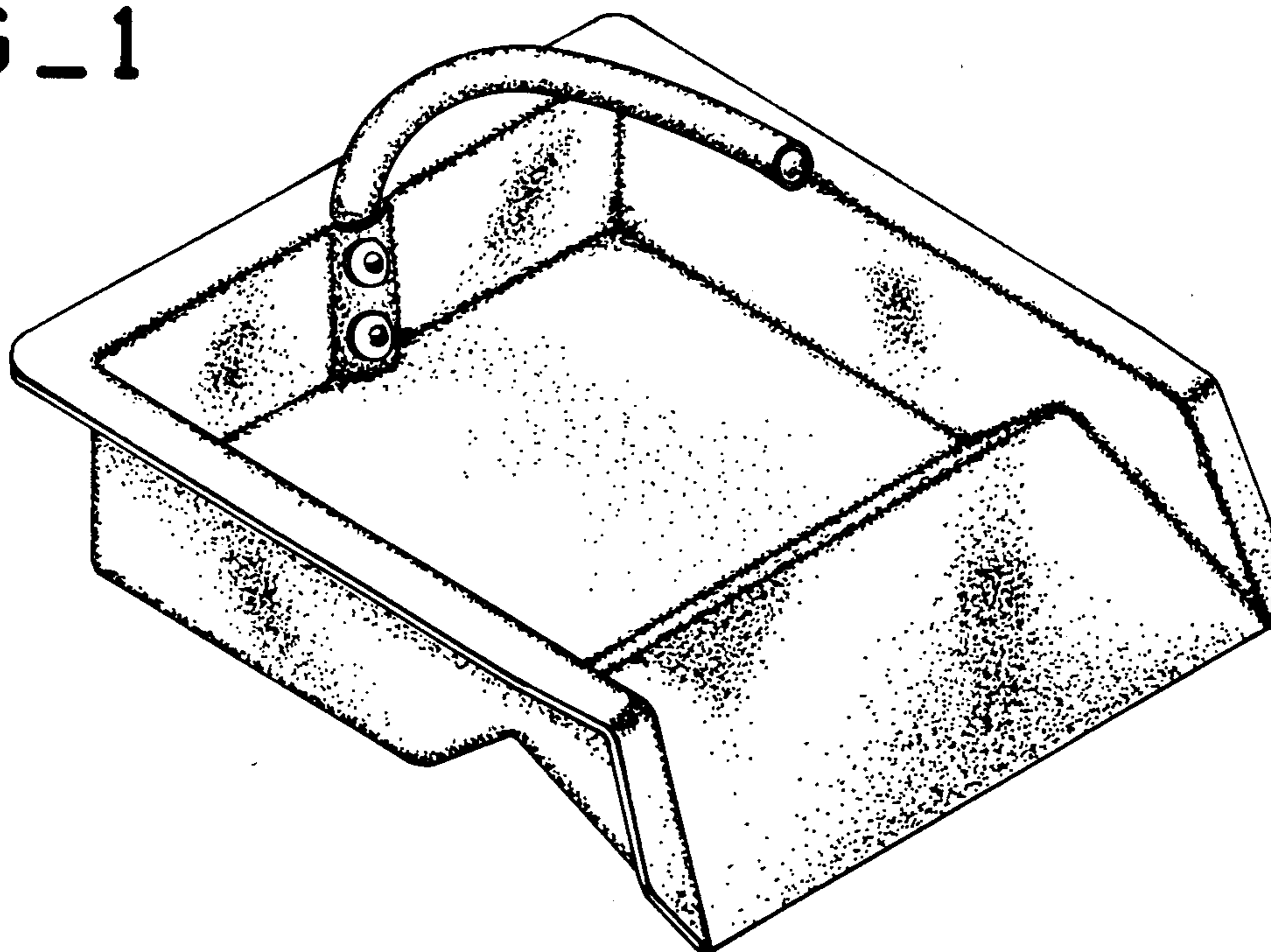

FIG _ 7

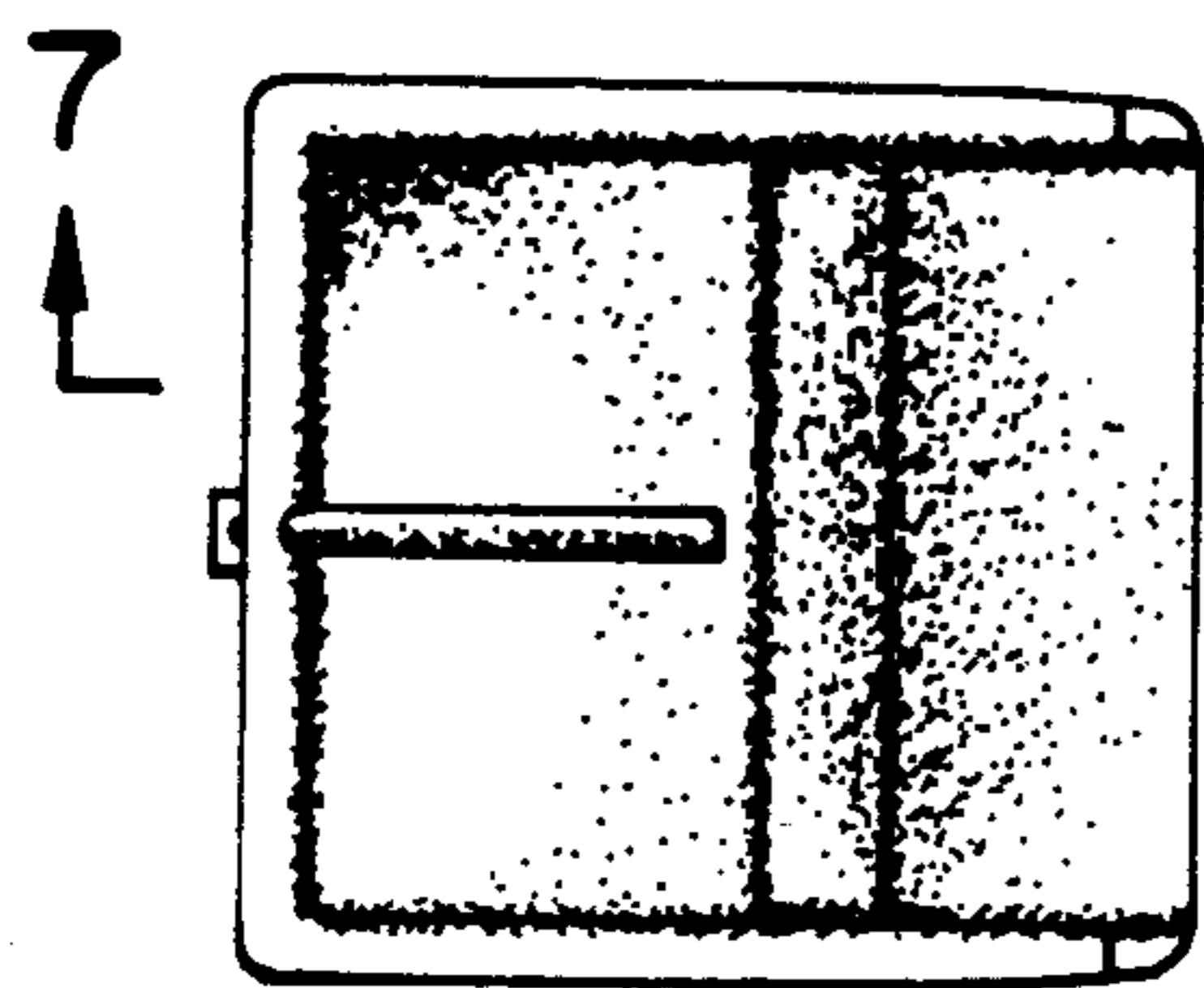

FIG _ 2

FIG _ 3

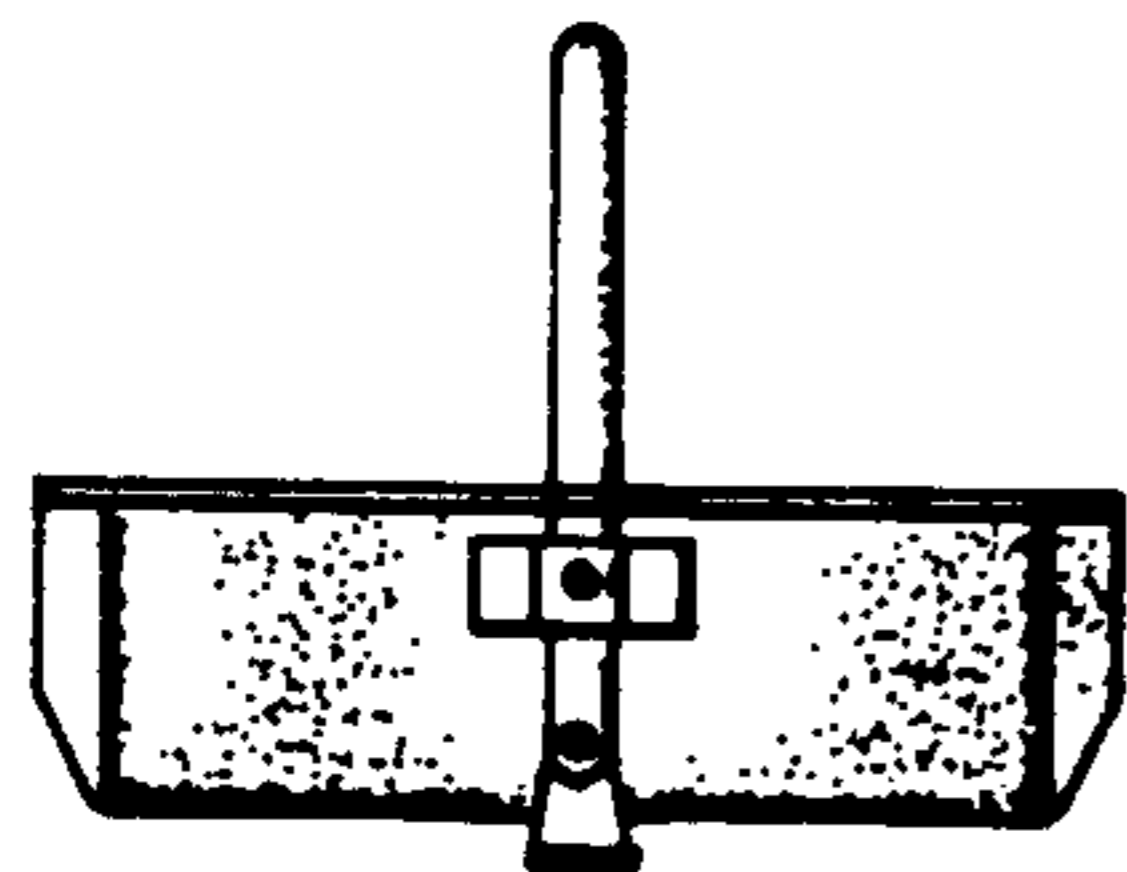
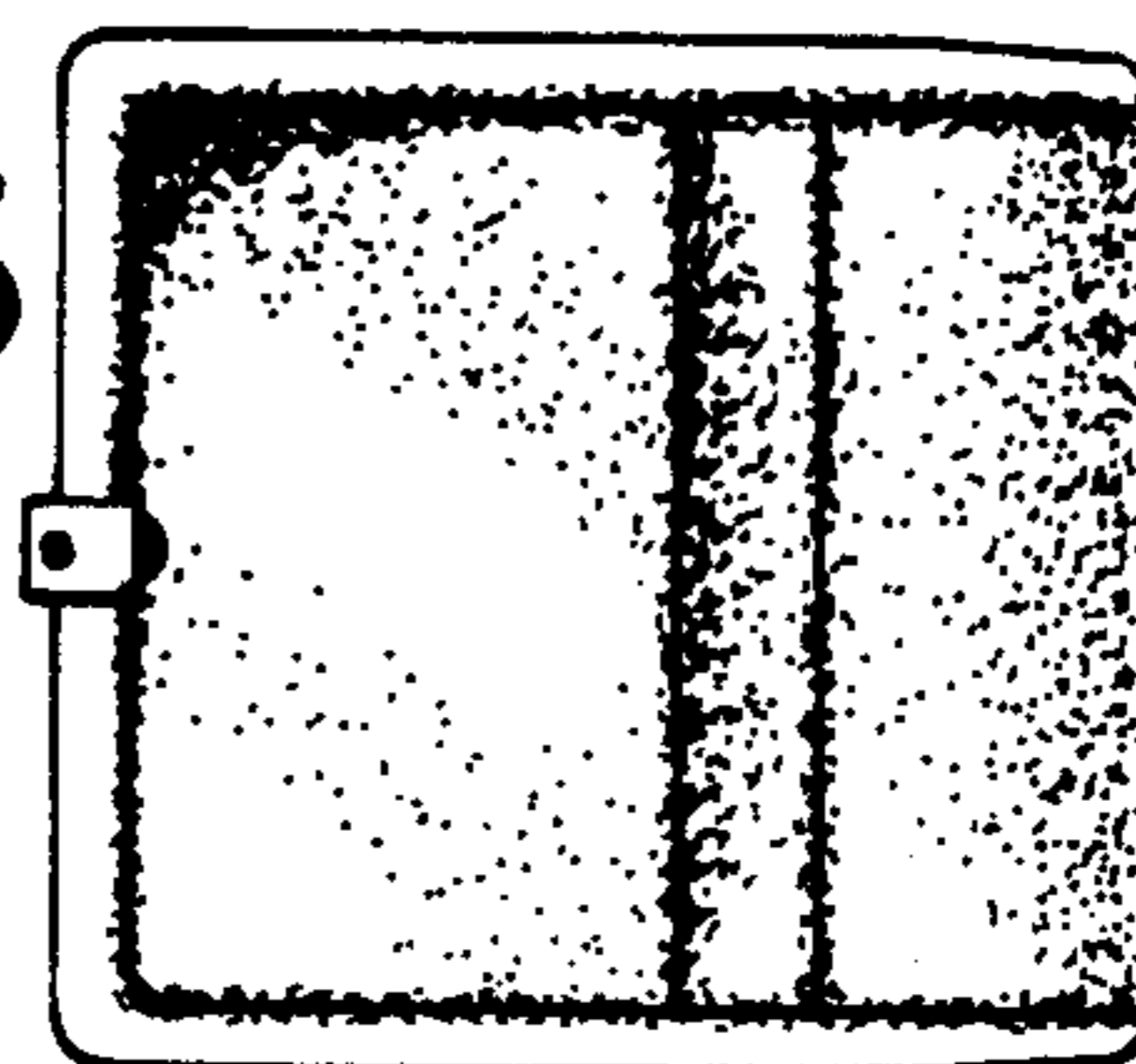

FIG _ 6

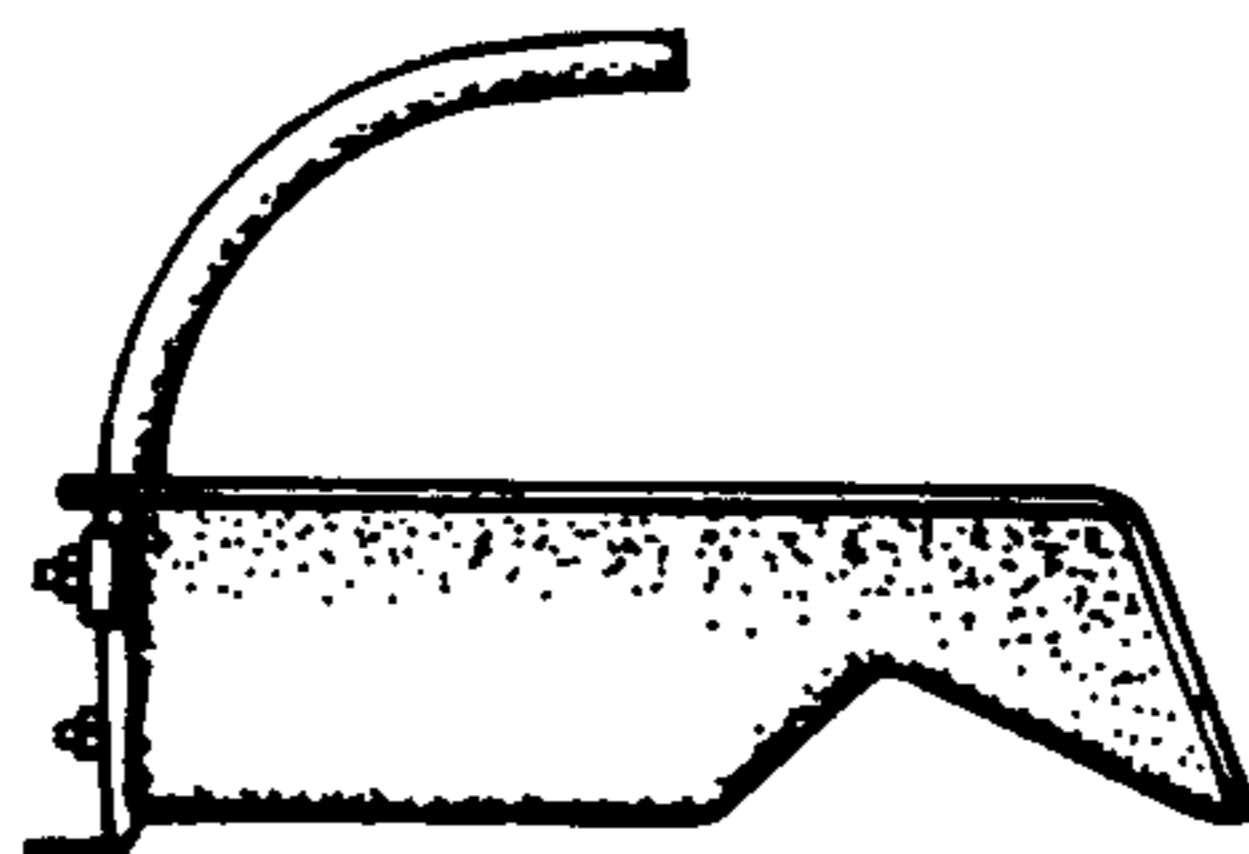

FIG _ 4

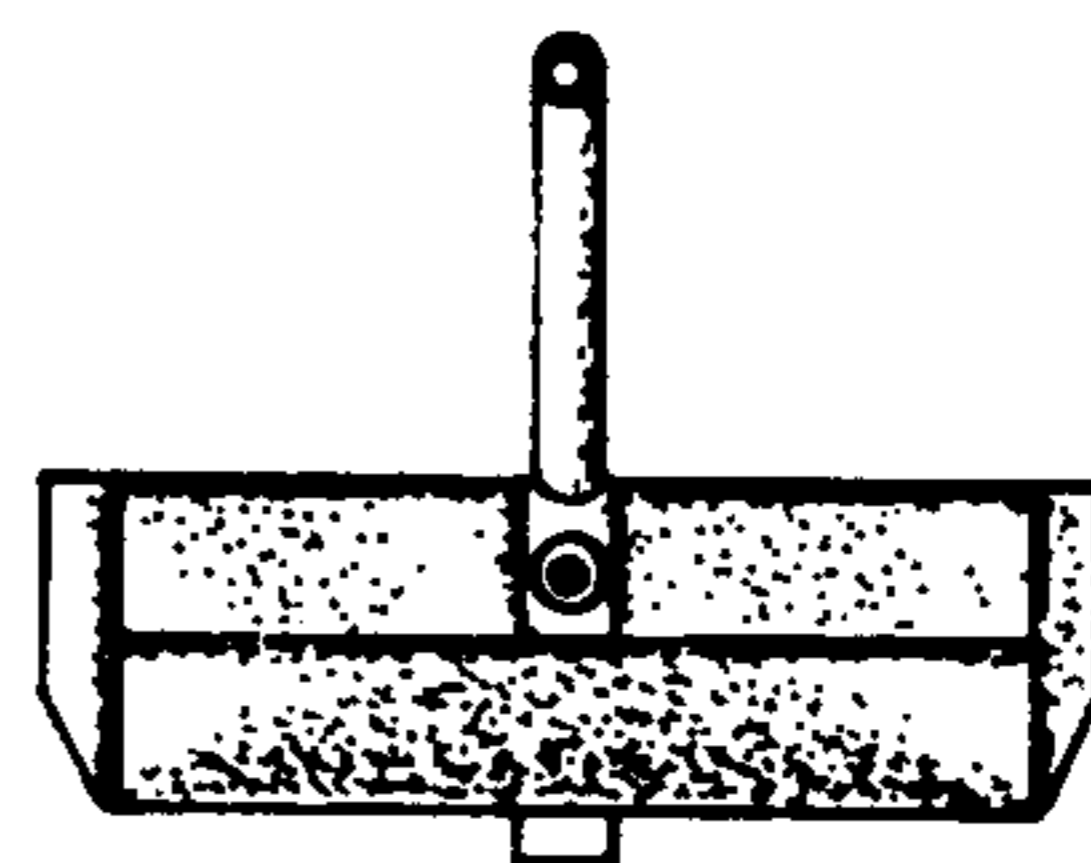

FIG _ 5