

[54] AUTOMOBILE CLEANING AND WAXING TOOL

D. 209,153 11/1967 Goldschein D8/62
D. 213,761 4/1969 Lee D8/62

[76] Inventors: Robert E. Burglin, 517 S. Archer, Anaheim, Calif. 92804; Sam S. Itaya, 420 Lakeview Rd., Pasadena, Calif. 91105

Primary Examiner—Bernard Ansher
Assistant Examiner—Catherine Kemper
Attorney, Agent, or Firm—Richard L. Gausewitz

[**] Term: 14 Years

[57] CLAIM

The ornamental design for an automobile cleaning and waxing tool, substantially as shown and described.

[21] Appl. No.: 785,195

DESCRIPTION

[22] Filed: Apr. 6, 1977

FIG. 1 is an isometric view of an automobile cleaning and waxing tool, showing our new design; FIG. 2 is a top plan view thereof; FIG. 3 is a side elevational view thereof; FIG. 4 is an isometric view of the bottom; FIG. 5 is an isometric view of a second embodiment, wherein the only difference resides in the shape of the upper portion of the housing; and FIG. 6 is an isometric view of a third embodiment, wherein the only difference resides in the shape of the upper portion of the housing.

[51] Int. Cl. D8—05; D15—05

[52] U.S. Cl. D8/62; D15/50

[58] Field of Search D8/61, 62, 67, 69, 70, D8/107; D15/34, 48, 50, 122, 124; 51/170; 15/22 R, 28, 49 R, 50 R, 52

[56] References Cited

U.S. PATENT DOCUMENTS

D. 202,694 11/1965 Rosenberg D15/50

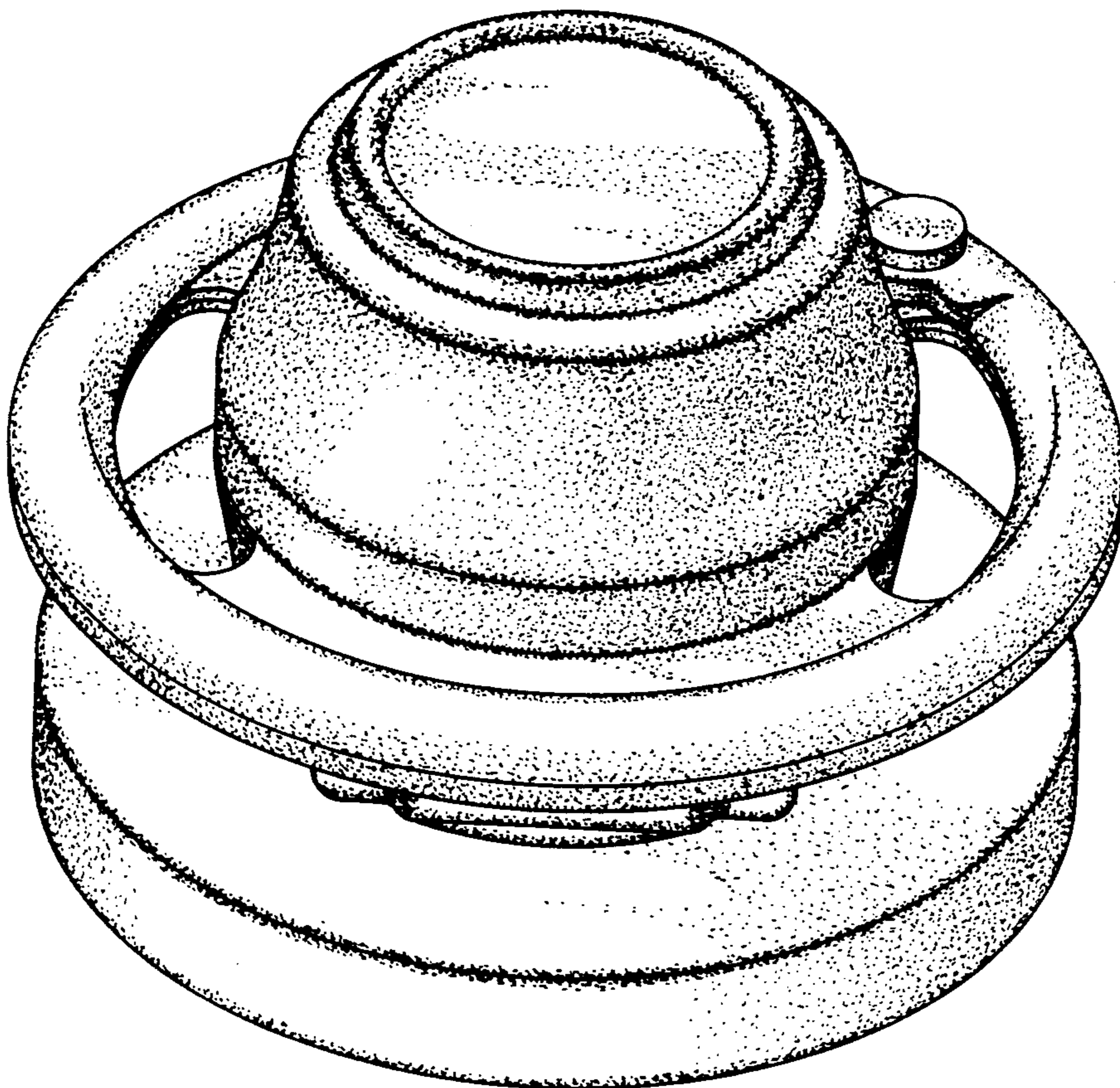

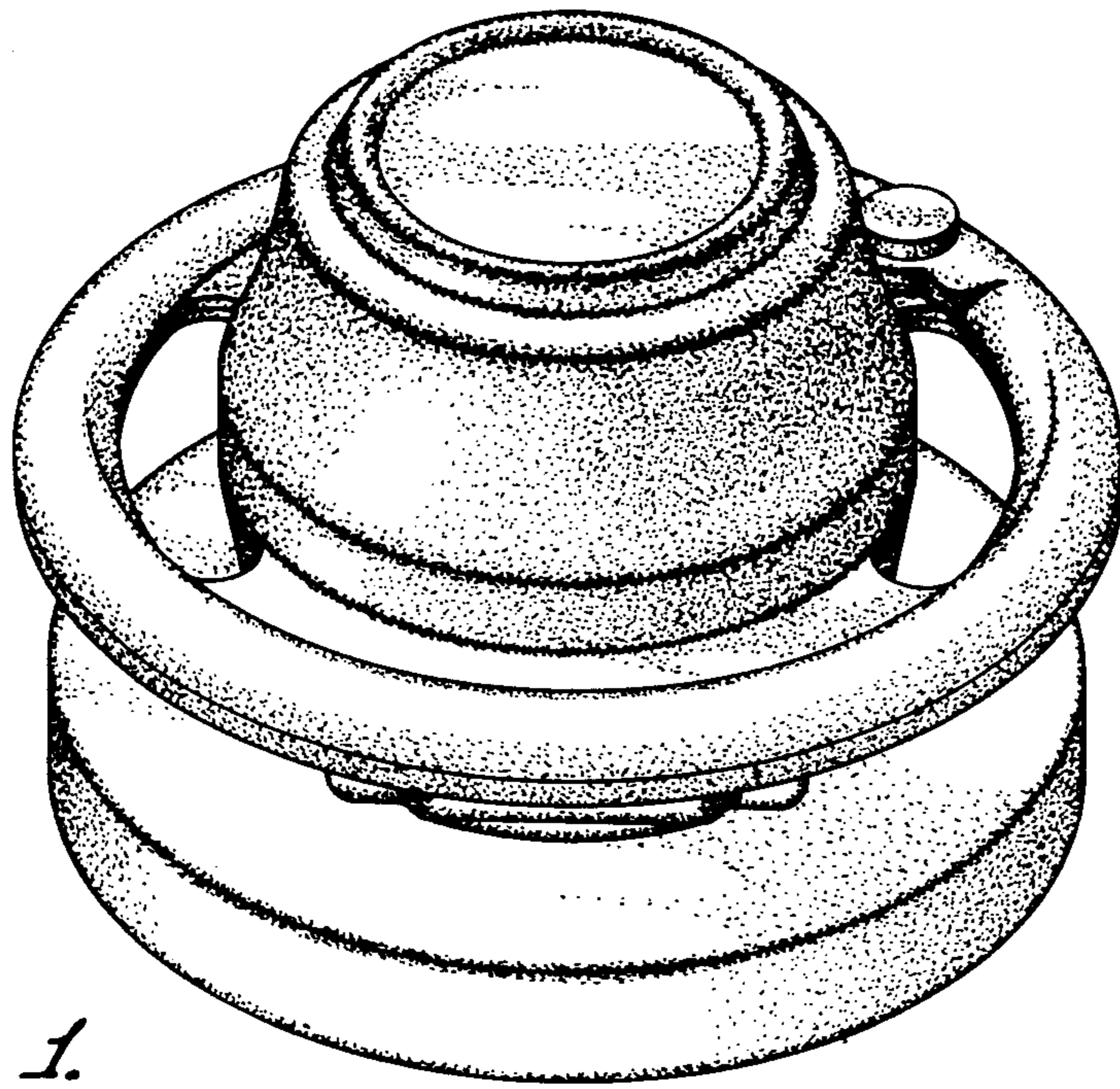

FIG. 1.

FIG. 2.

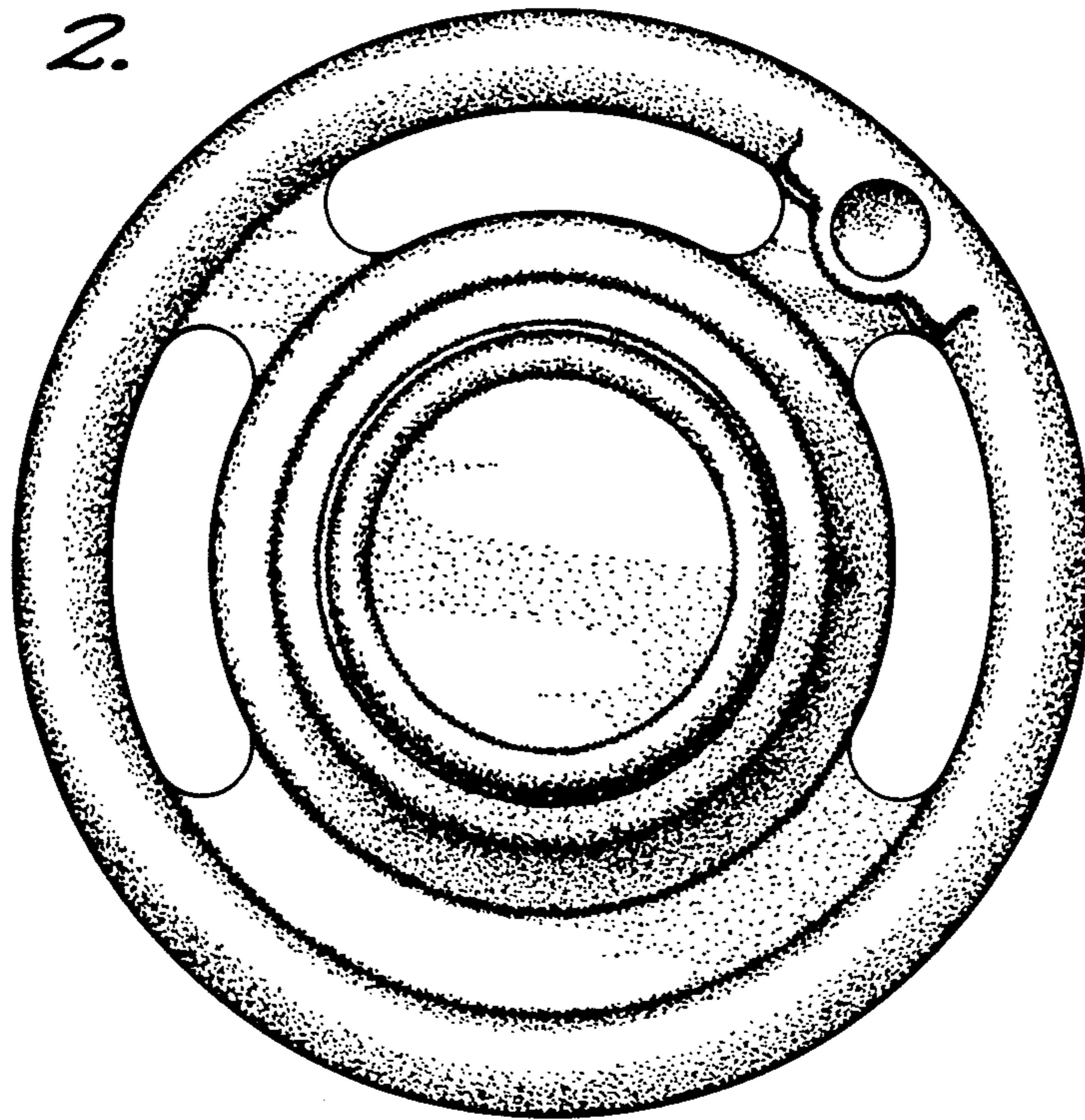

FIG. 3.

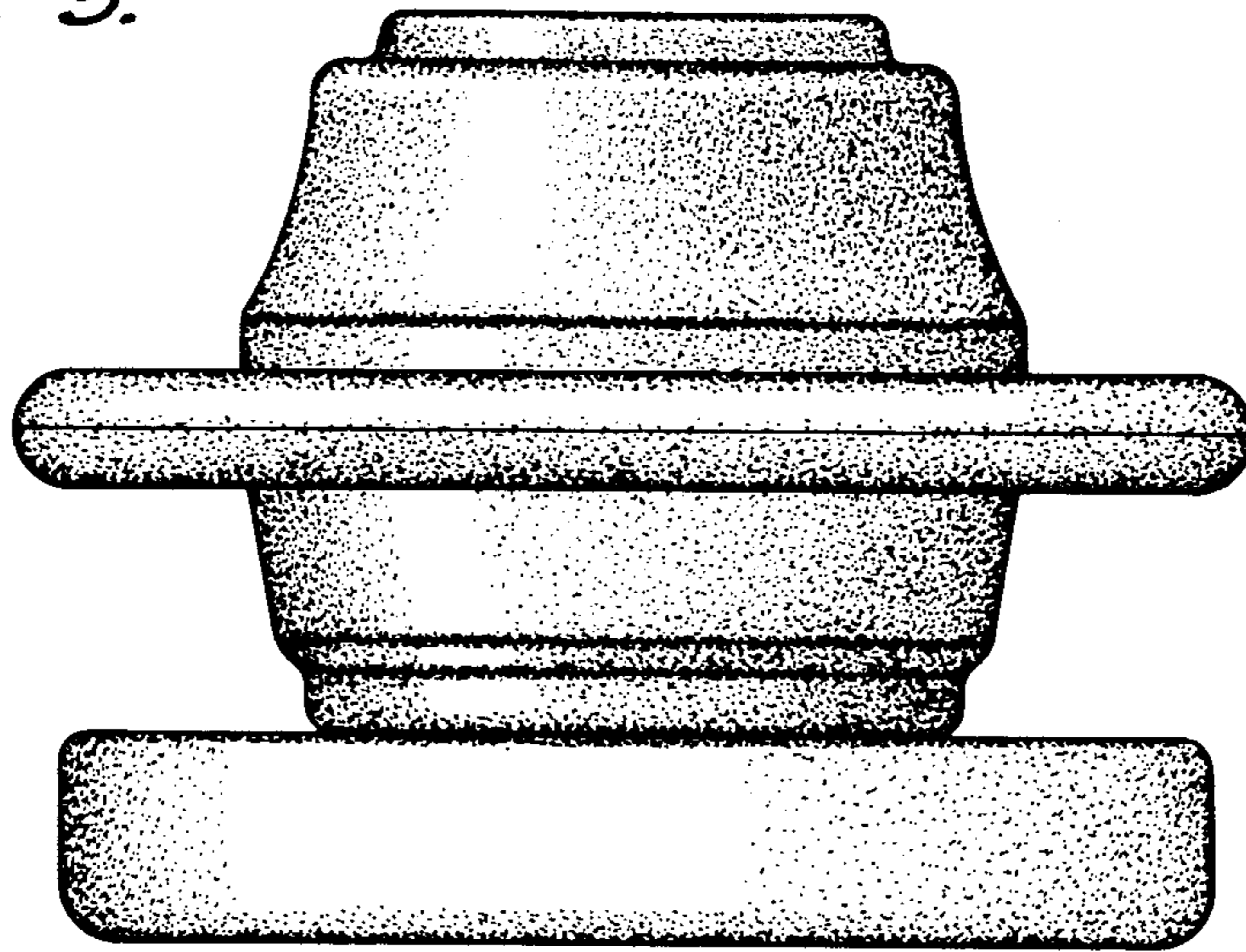
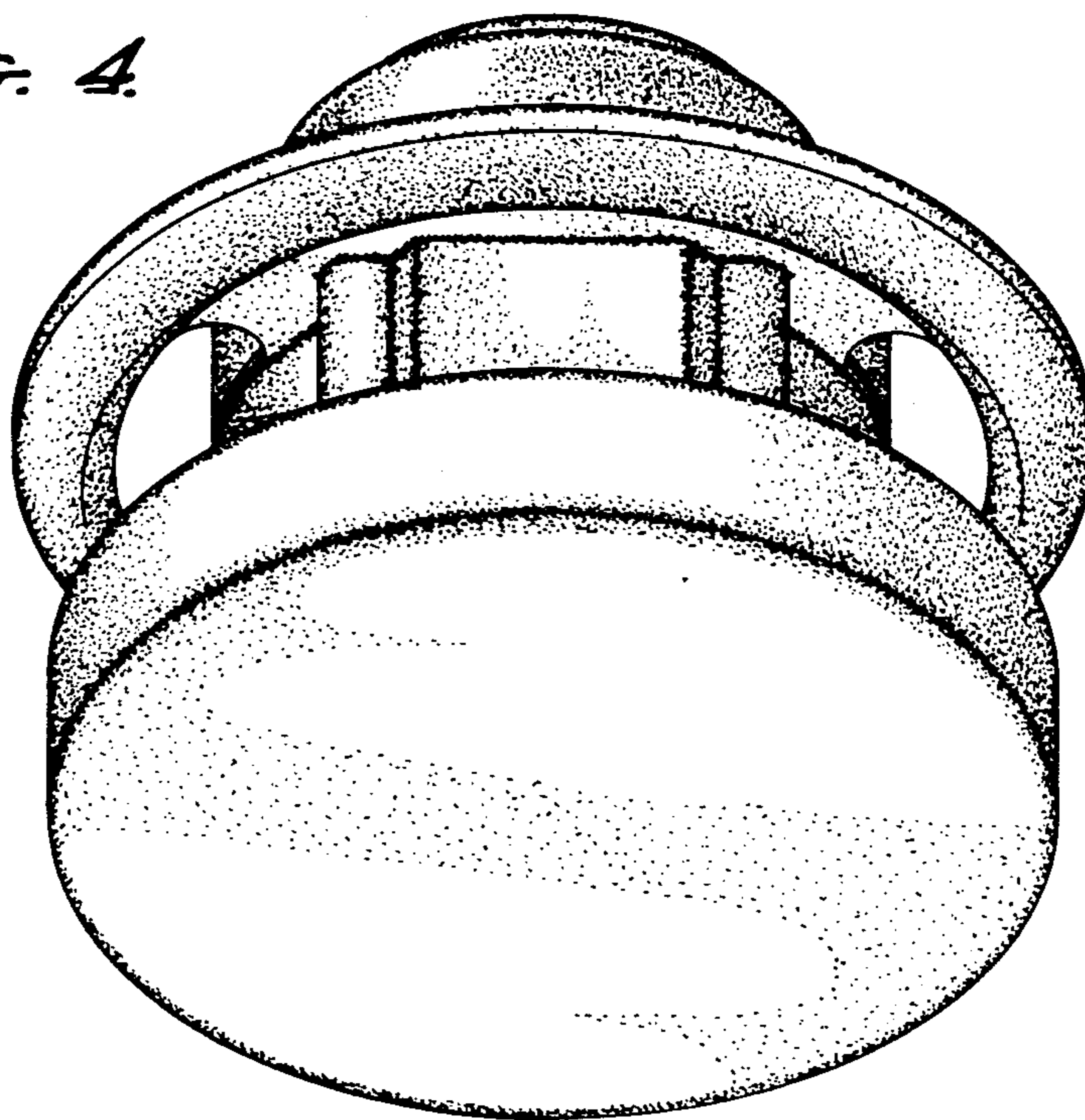

FIG. 4.



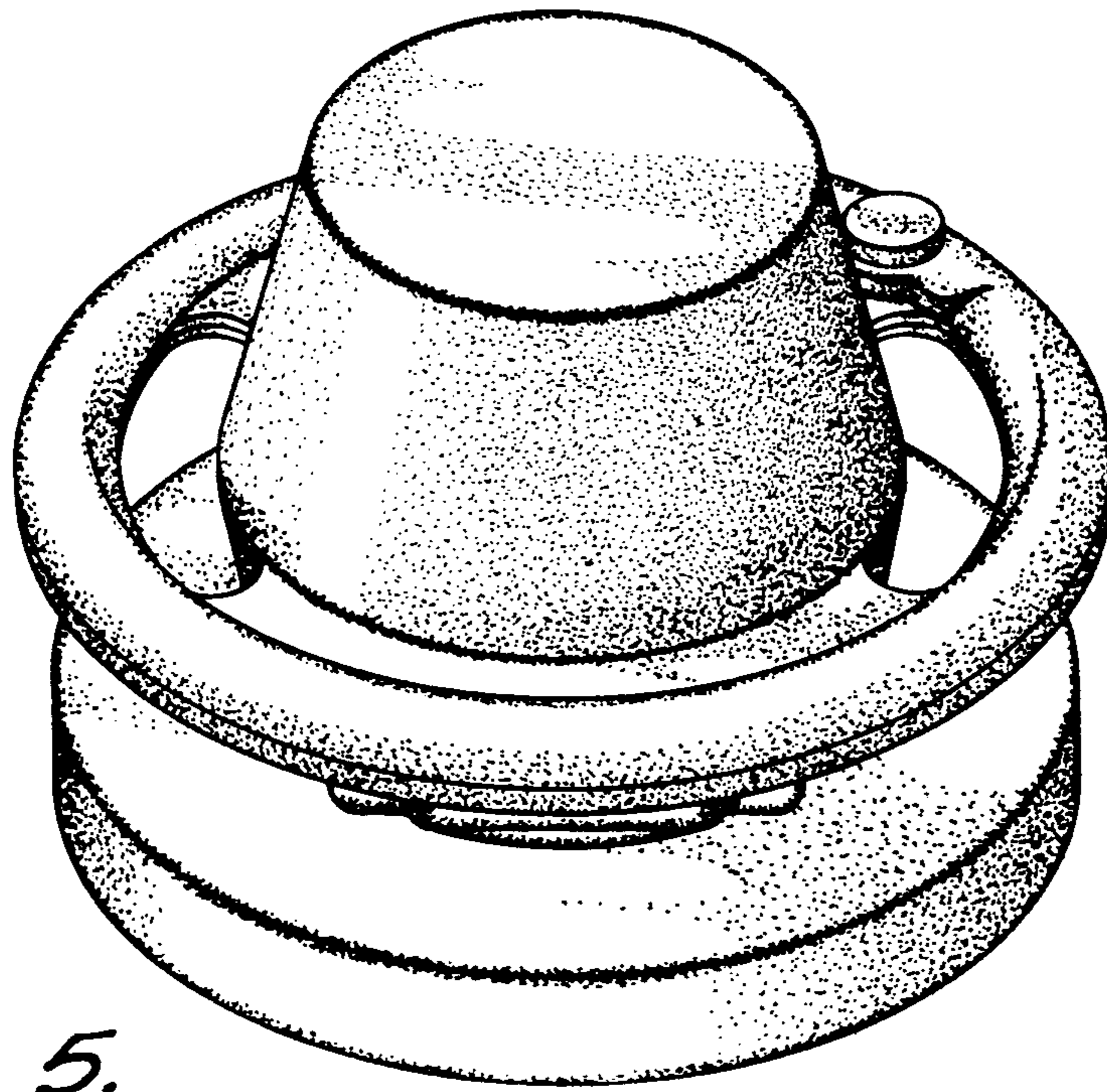

FIG. 5.

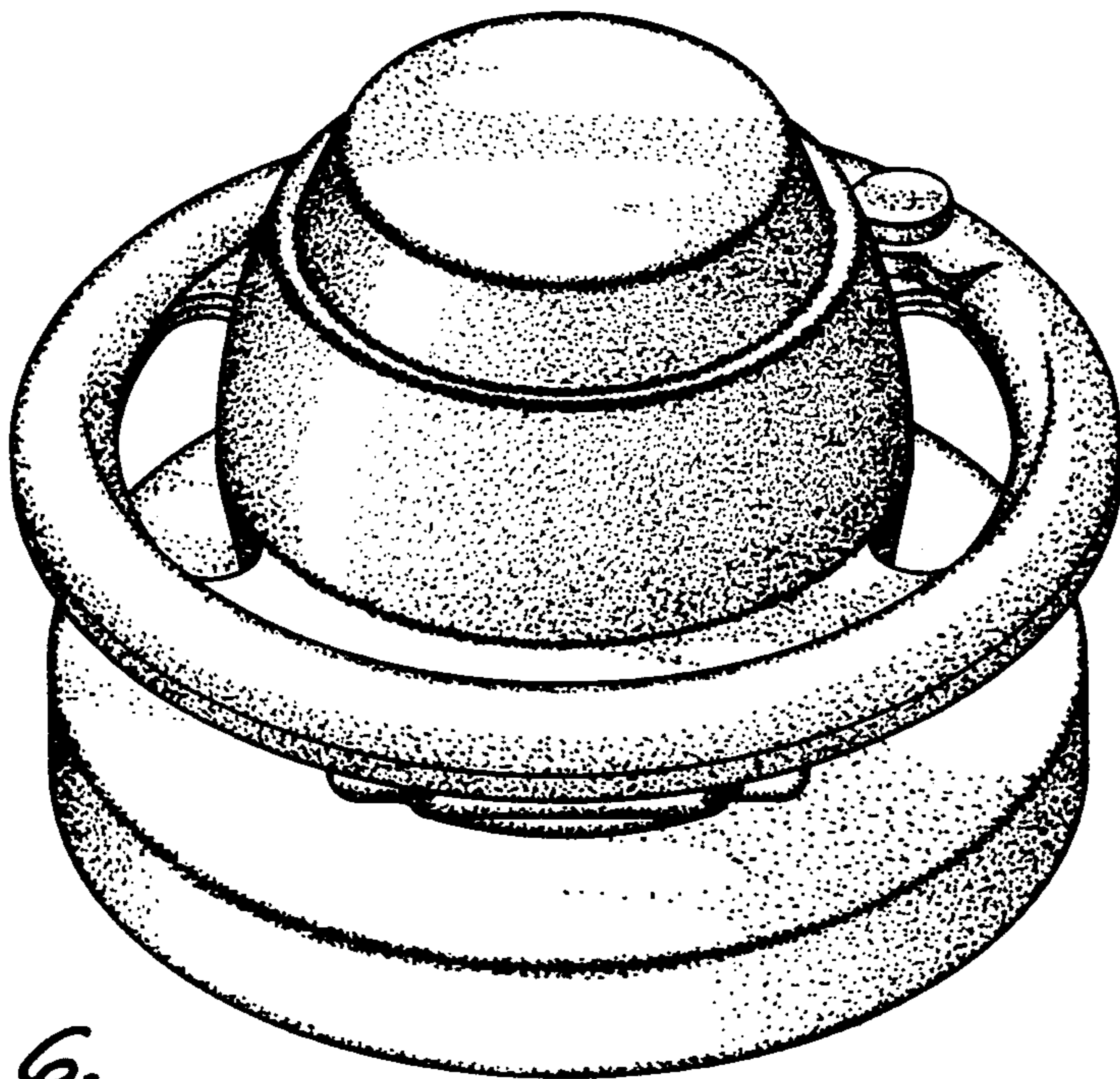

FIG. 6.