

[54] COMBINED TAILPIECE, BRIDGE AND MUTE UNIT FOR A GUITAR OR THE LIKE

[75] Inventor: James H. Rickard, Harwinton, Conn.

[73] Assignee: Ovation Instruments, Inc., New Hartford, Conn.

[**] Term: 14 Years

[21] Appl. No.: 760,751

[22] Filed: Jan. 19, 1977

[51] Int. Cl. D17-03

[52] U.S. Cl. D17/20

[58] Field of Search D56/1 R, 1 A; 84/267, 84/291, 292, 299; D17/20

[56] References Cited

U.S. PATENT DOCUMENTS

615,053	11/1898	Utt	84/299
2,222,959	11/1940	Stathopoulos	84/267
3,015,247	1/1962	Allers	84/267 X

FOREIGN PATENT DOCUMENTS

126992	1/1902	Fed. Rep. of Germany	84/299
143434	11/1935	Fed. Rep. of Germany	84/267

Primary Examiner—Joel Stearman
Assistant Examiner—Jane E. Corrigan
Attorney, Agent, or Firm—Donald K. Huber

[57] CLAIM

The ornamental design for a combined tailpiece, bridge and mute unit for a guitar or the like, as shown and described.

DESCRIPTION

FIG. 1 is a front elevational view of a combined tailpiece, bridge and mute unit for a guitar or the like showing my new design;
FIG. 2 is a rear elevational view;
FIG. 3 is a top plan view;
FIG. 4 is a bottom plan view;
FIG. 5 is a left side elevational view;
FIG. 6 is a right side elevational view; and
FIG. 7 is a sectional view taken along line 7—7 in FIG. 1.

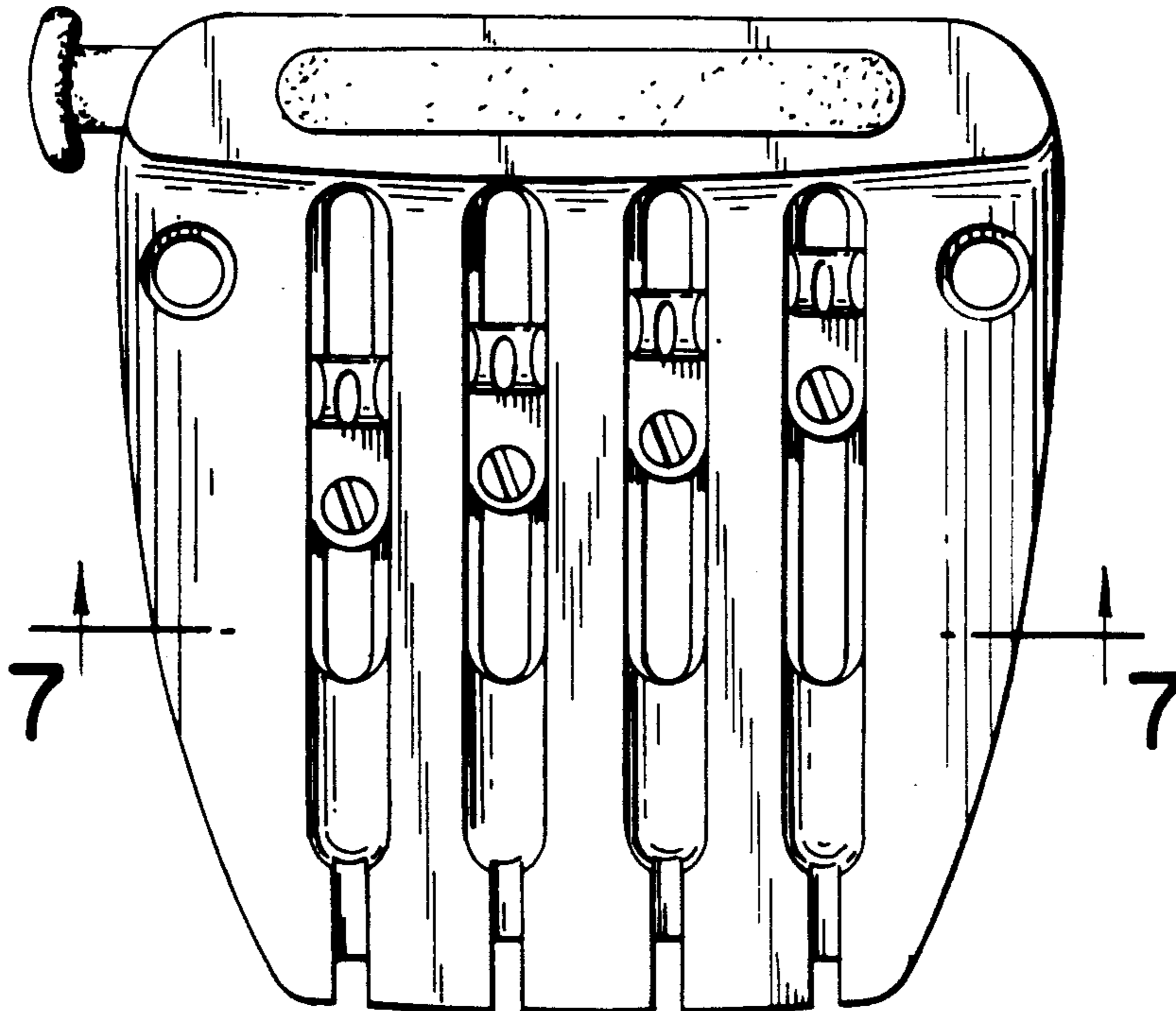

FIG. 1

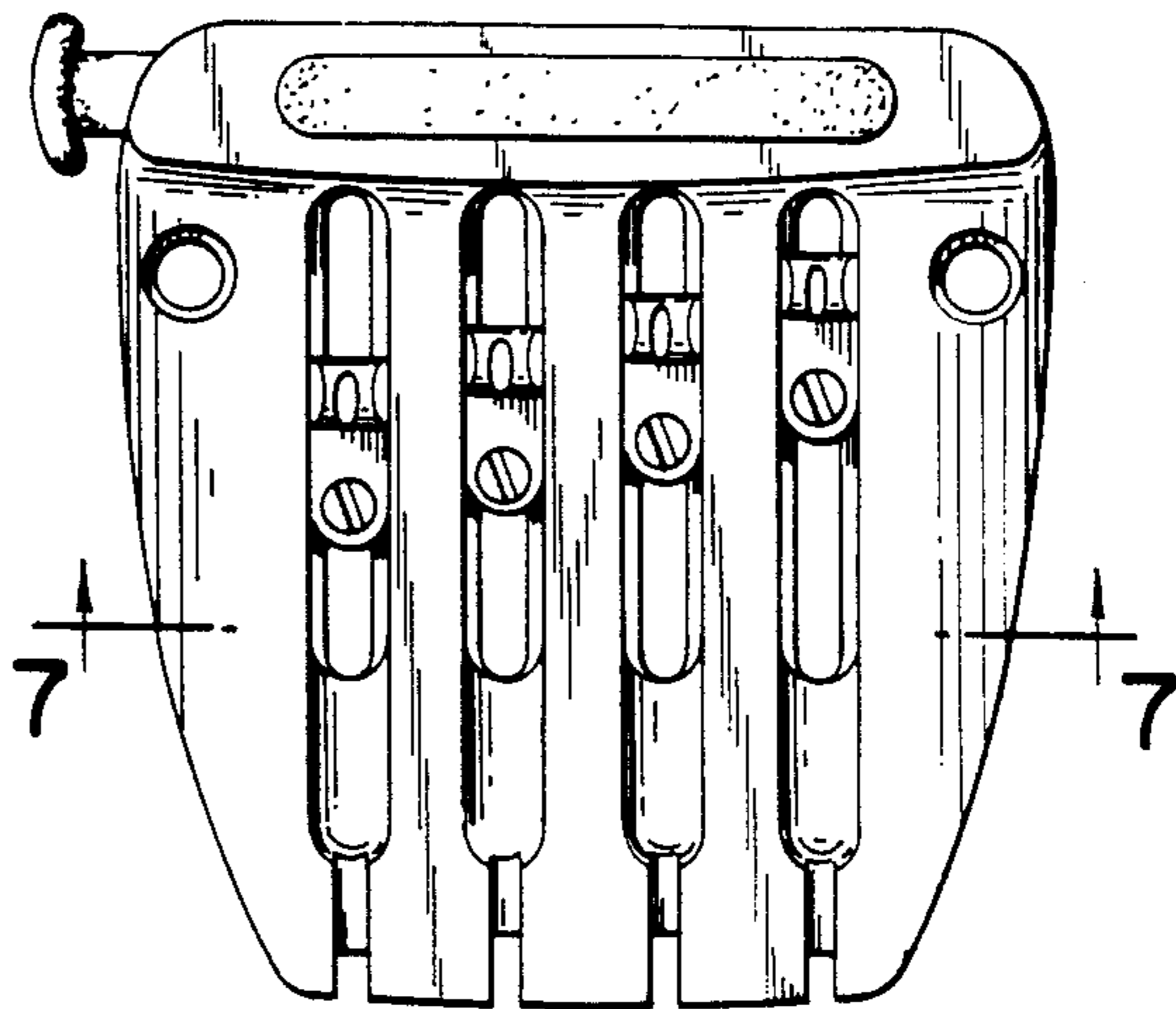

FIG. 2

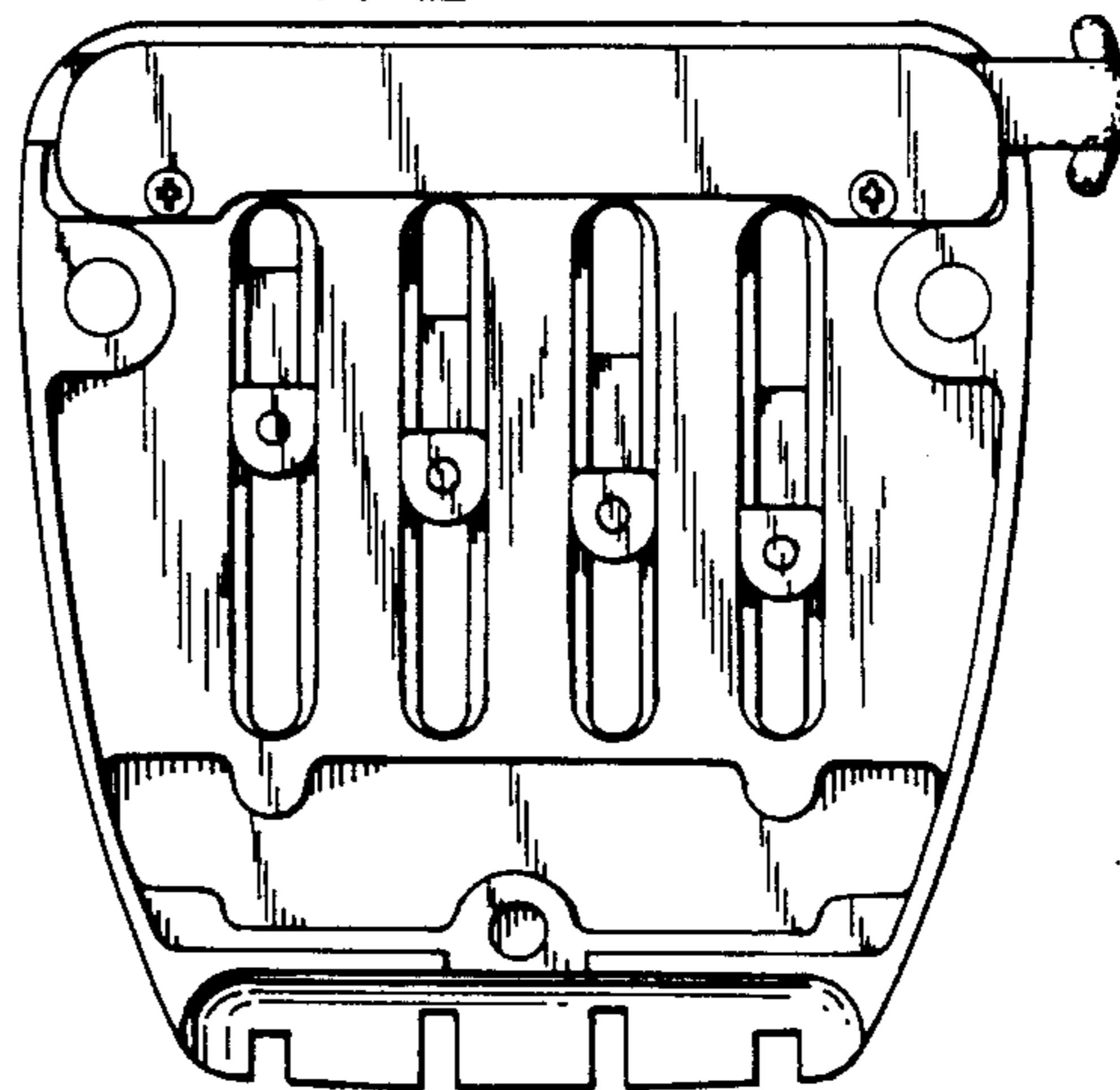

FIG. 3



FIG. 4

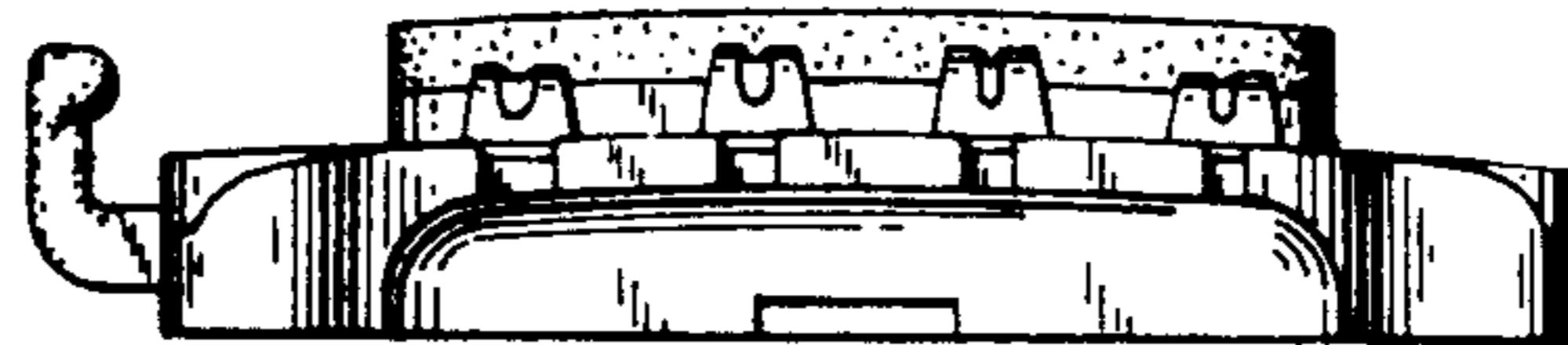

FIG. 7

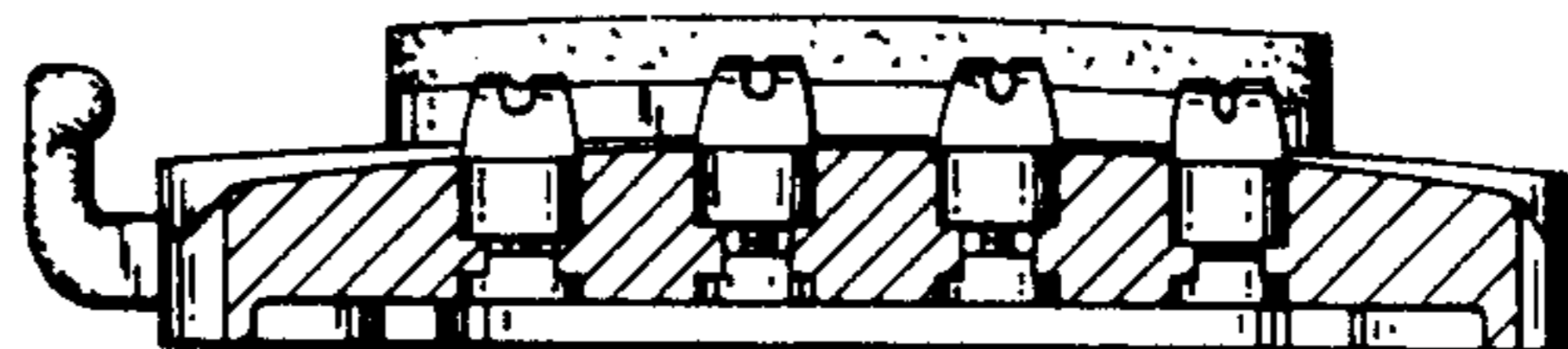

FIG. 5

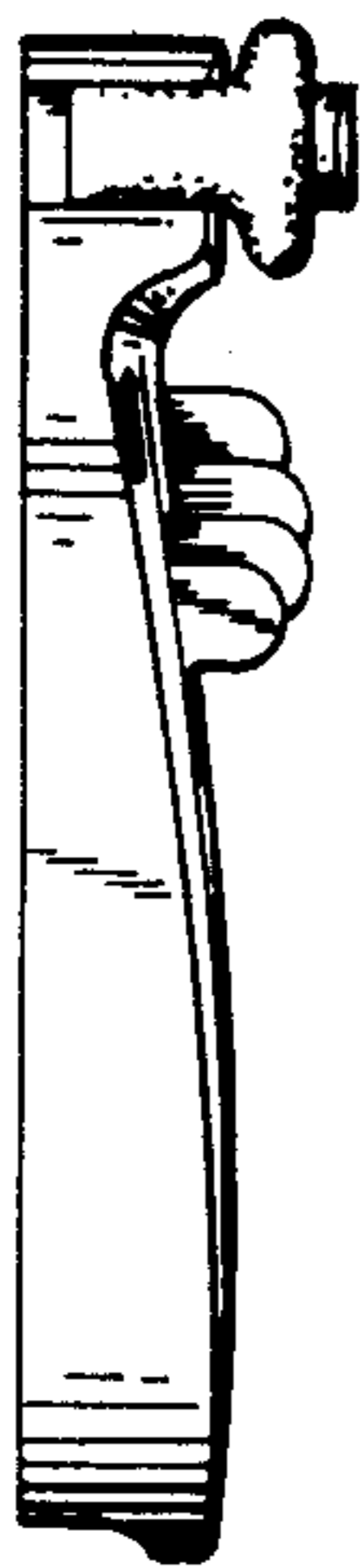

FIG. 6

