

[54] SPOKED VEHICLE WHEEL

[75] Inventor: **Ronald D. Retzlaff**, Anaheim, Calif.

[73] Assignee: **Tru-Spoke, Inc.**, Anaheim, Calif.

[\*\*] Term: **14 Years**

[21] Appl. No.: **911,442**

[22] Filed: **Jun. 1, 1978**

[51] Int. Cl. .... **D12-16**  
 [52] U.S. Cl. .... **D12/205**  
 [58] Field of Search ..... **D12/205; 301/55, 58,**  
**301/59, 63 R, 63 DD, 63 DT, 63 PW, 64 R, 64**  
**SH, 64 SD, 65, 66, 73, 74, 79, 95, 9 S, 9 SB, 9**  
**SC, 37 SS**

[56] **References Cited**

**U.S. PATENT DOCUMENTS**

D. 218,232 8/1970 Shimano et al. .... D12/205  
 D. 241,421 9/1976 Lohmeyer ..... D12/205

**OTHER PUBLICATIONS**

Street Rod, 8/72, p. 29, Packard Wheel, bottom left side of page.

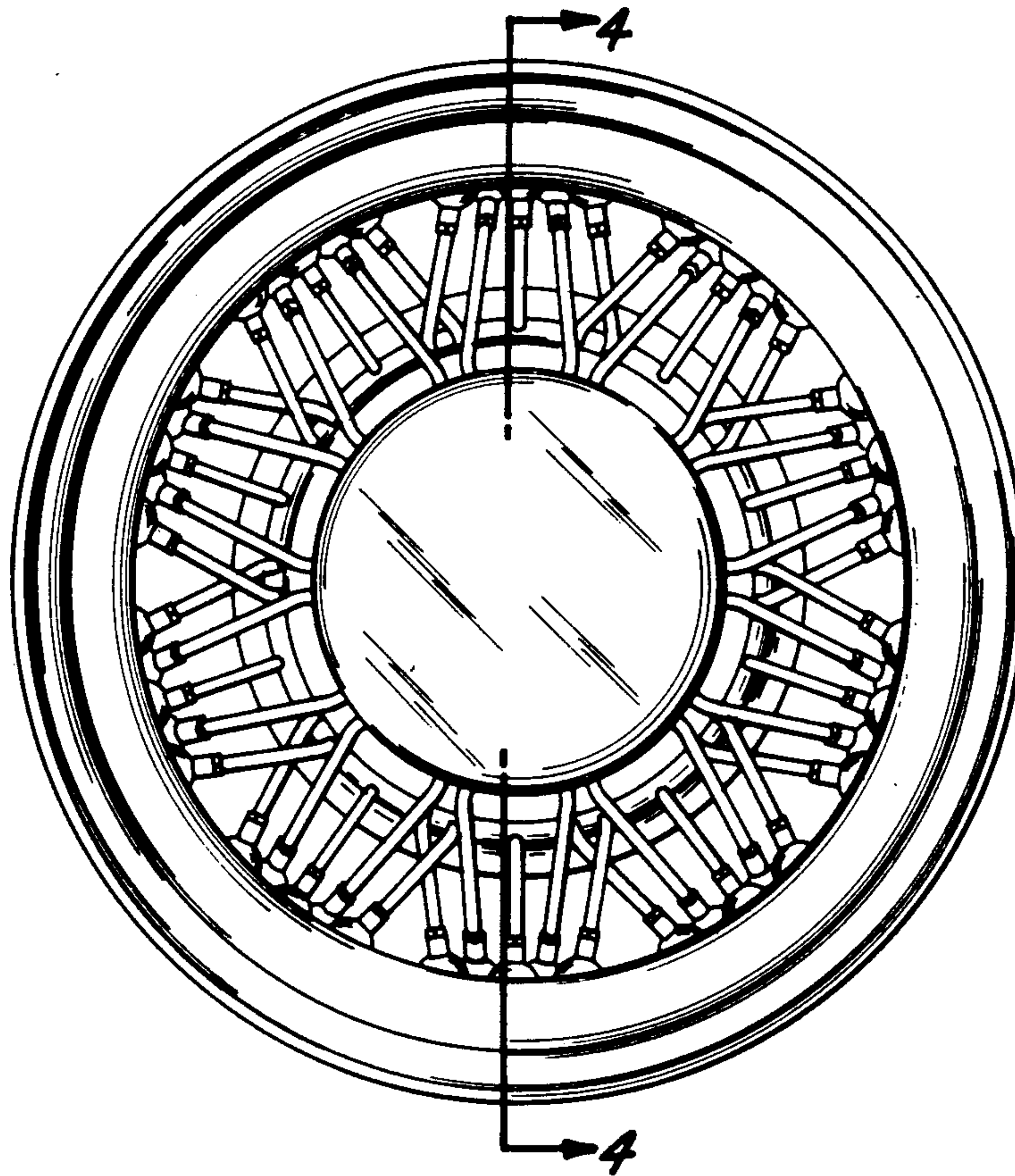
*Primary Examiner*—James M. Gandy  
*Attorney, Agent, or Firm*—Gerald L. Price

[57] **CLAIM**

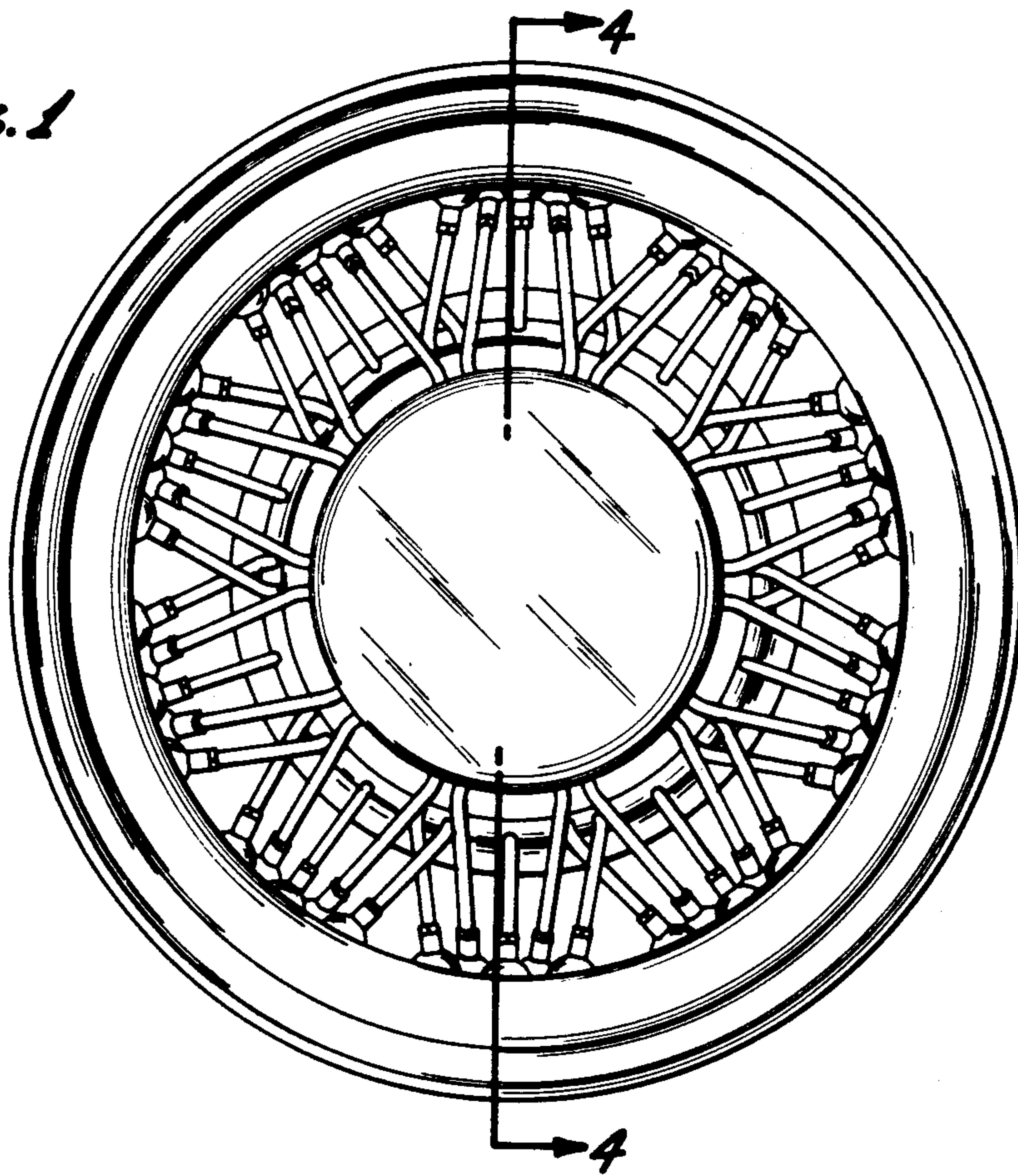
The ornamental design for a spoked vehicle wheel, as shown.

**DESCRIPTION**

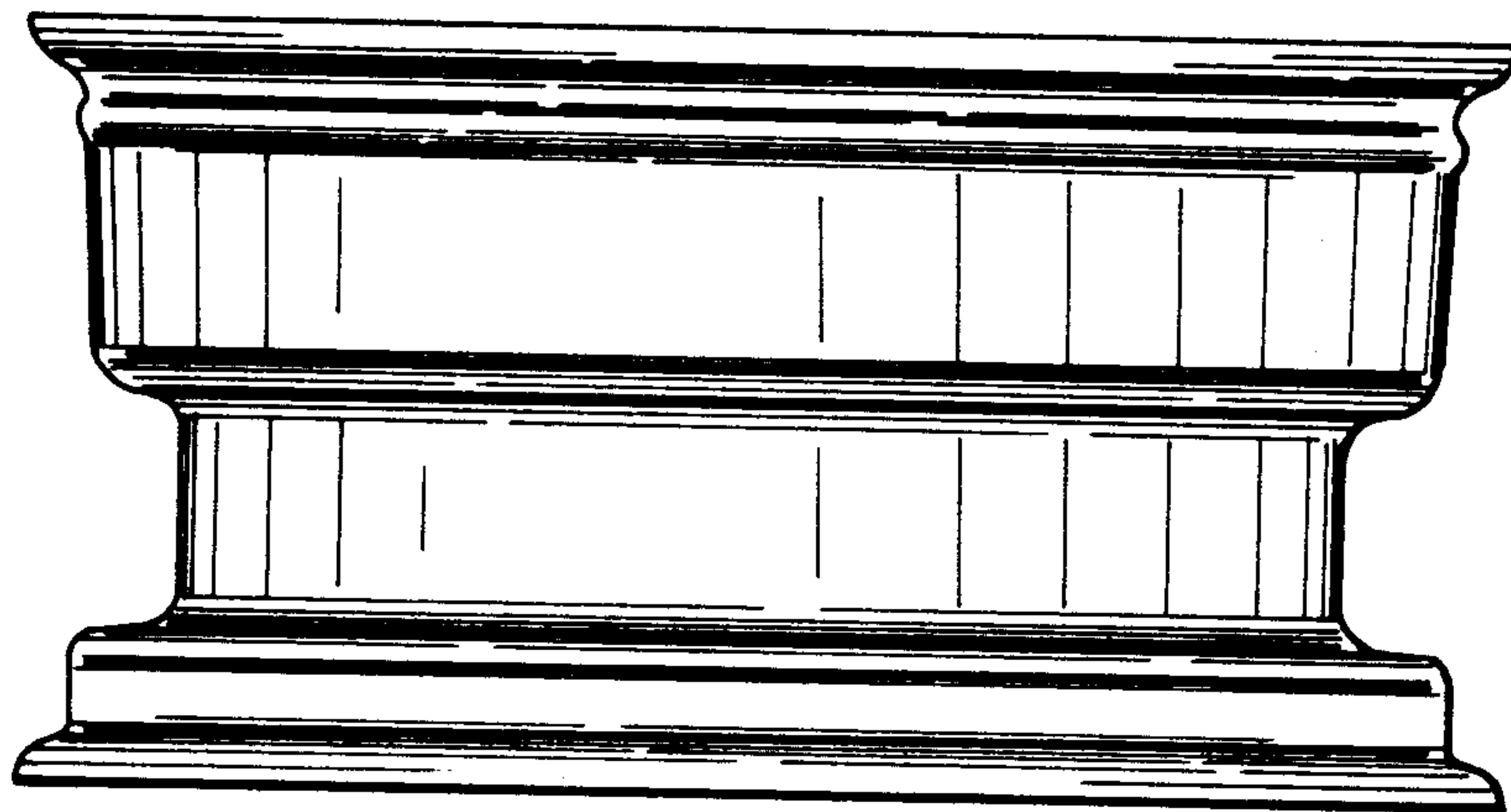
FIG. 1 is a front elevational view of a spoked vehicle wheel showing my new design;  
 FIG. 2 is an end elevational view thereof;  
 FIG. 3 is a rear elevational view thereof and,  
 FIG. 4 is a sectional view thereof taken on line 4—4 of FIG. 1.



*Fig. 1*

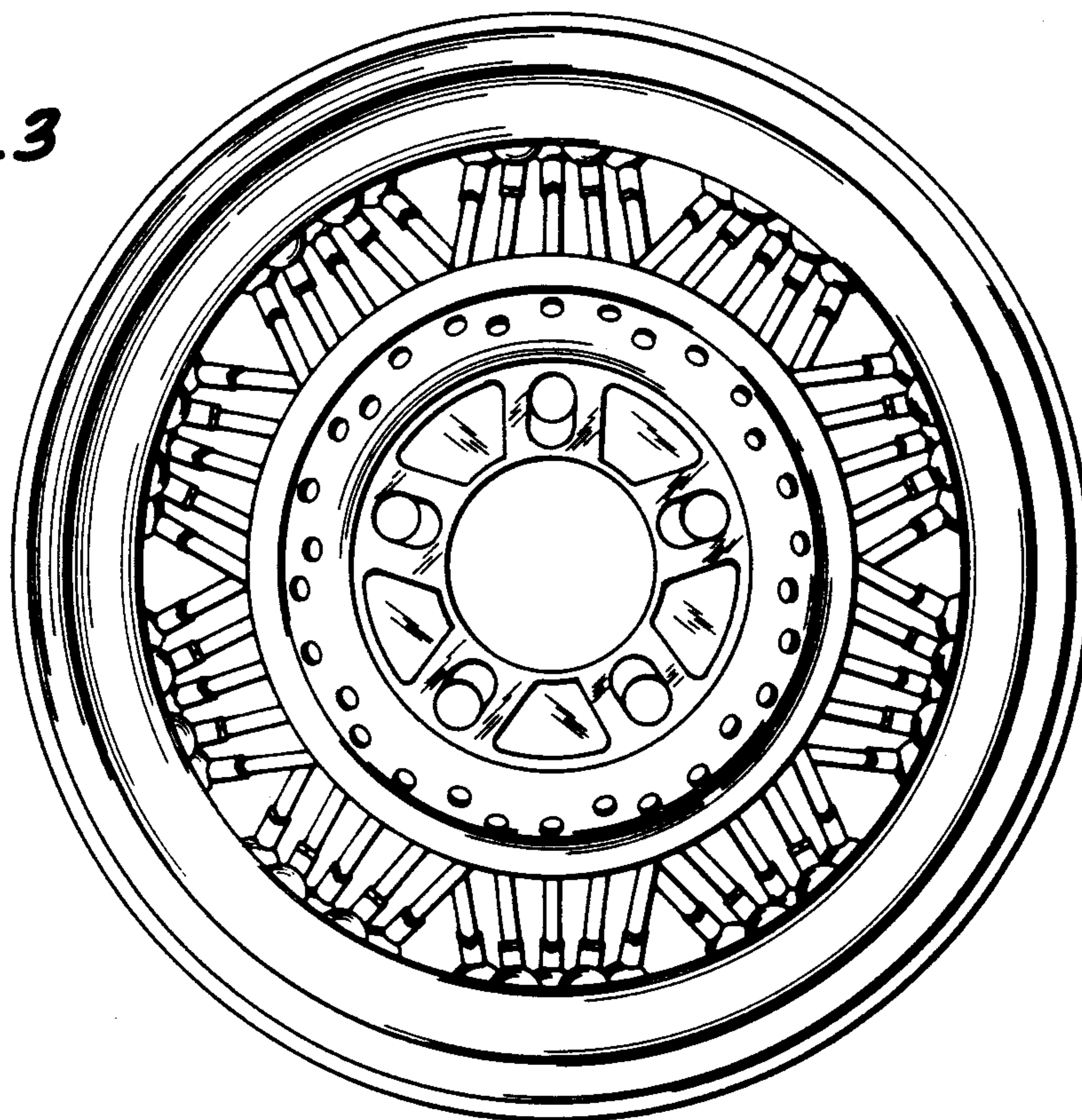


*Fig. 2*





*Fig. 3*



*Fig. 4*

