

[54] TRUCK CAB

[76] Inventors: **Charlene Spellins; Richard E. Muraski**, both of 1413 Robertson Blvd., Chowchilla, Calif. 93610

[**] Term: **14 Years**

[21] Appl. No.: **850,085**

[22] Filed: **Nov. 10, 1977**

[51] Int. Cl. **D12-08**
[52] U.S. Cl. **D12/96**
[58] Field of Search **D12/96, 97; 180/89.1, 180/89.12, 89.16; 296/28 C**

[56]

References Cited

U.S. PATENT DOCUMENTS

D. 236,606 9/1975 Bodden D12/96
D. 242,996 1/1977 Servais et al. D12/97

Primary Examiner—James M. Gandy
Attorney, Agent, or Firm—George J. Netter

[57]

CLAIM

The ornamental design for a truck cab, as shown and described.

DESCRIPTION

FIG. 1 is a perspective view of a truck cab showing our design.

FIG. 2 is a front elevational view thereof.

FIG. 3 is a side elevational view thereof.

FIG. 4 is a top plan view thereof.

The side opposite to that shown in FIG. 3 is a mirror image thereof, and the rear of the cab is substantially plain and unornamented.

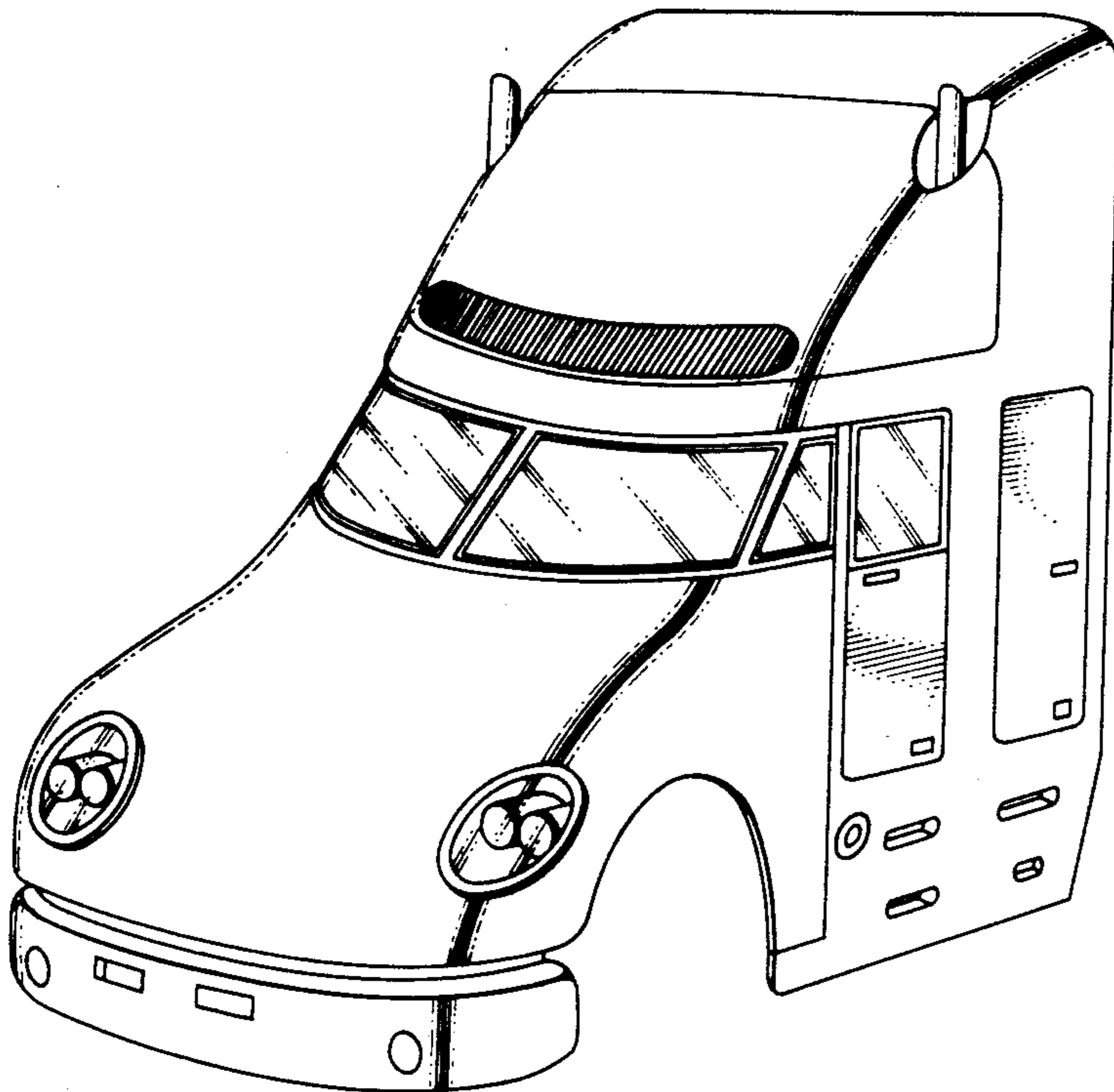

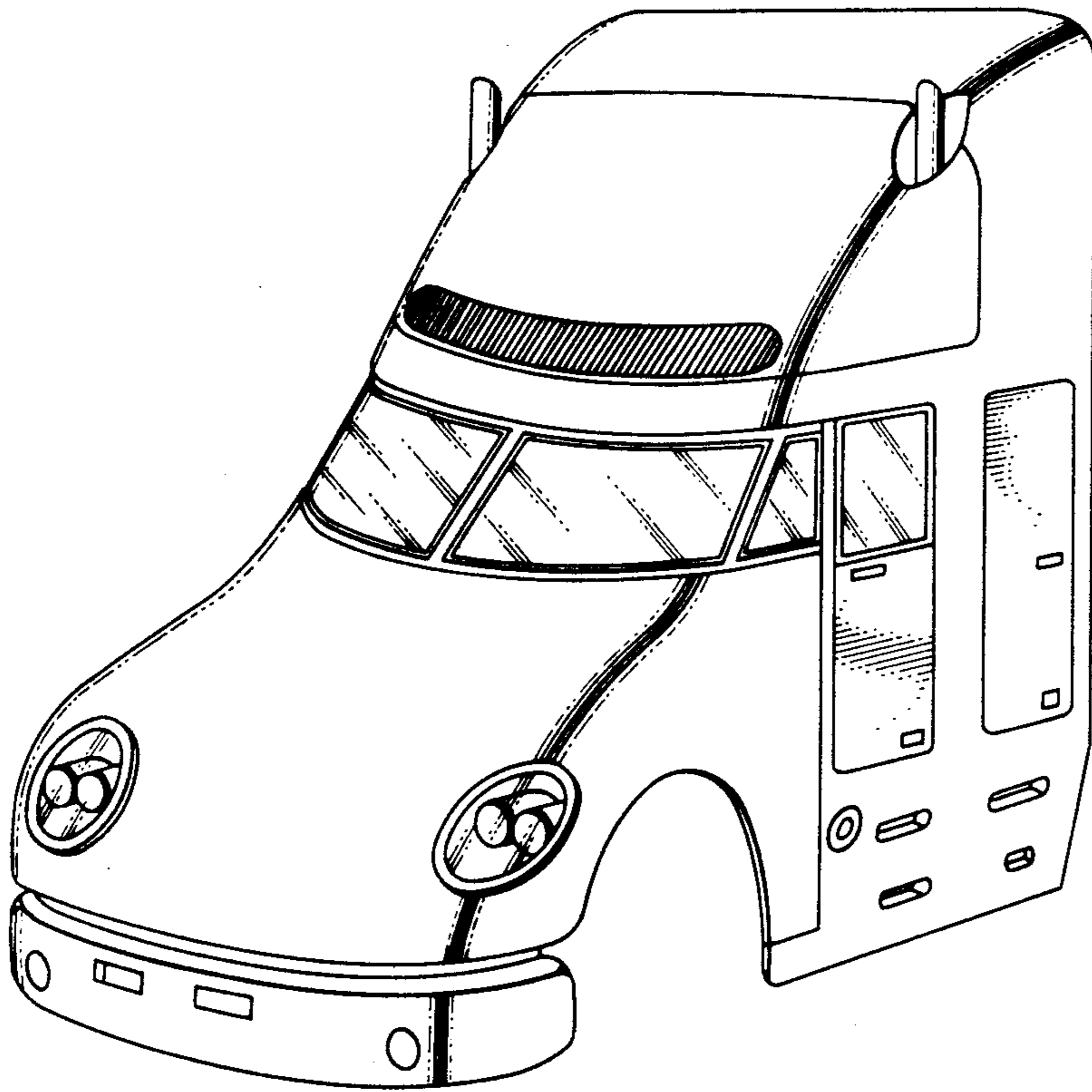

FIG. 1.

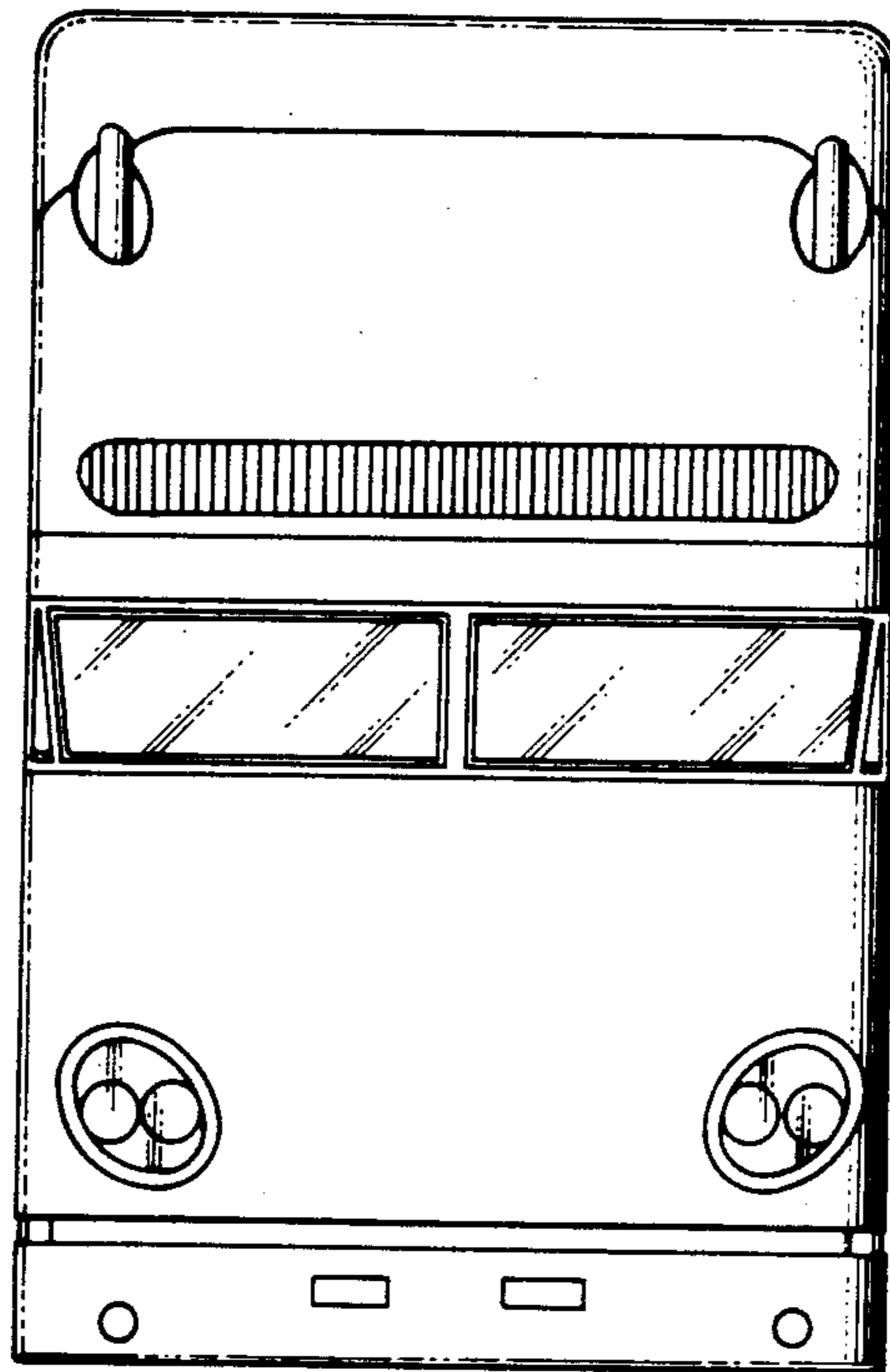

FIG 2.

FIG. 3.

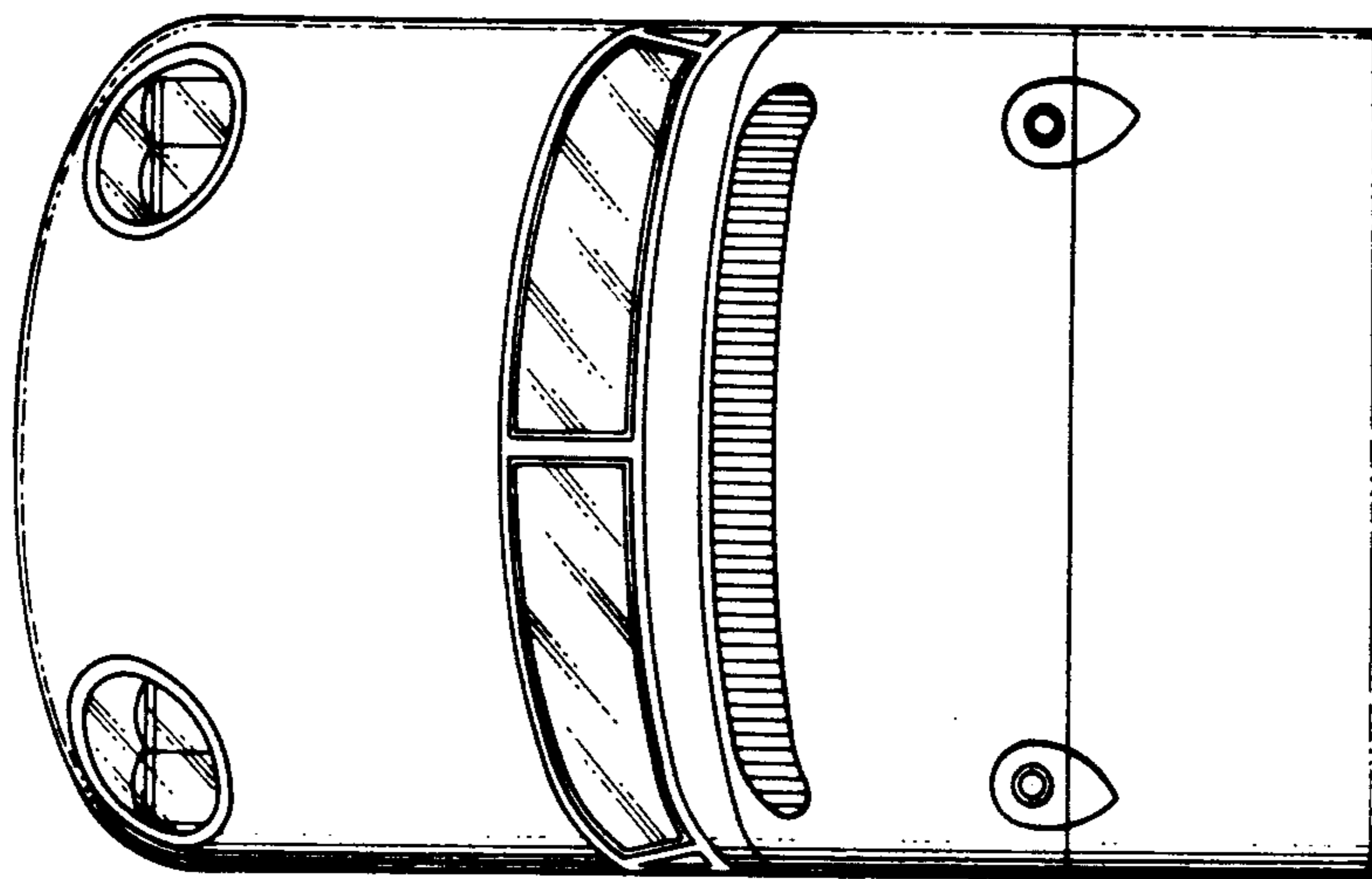
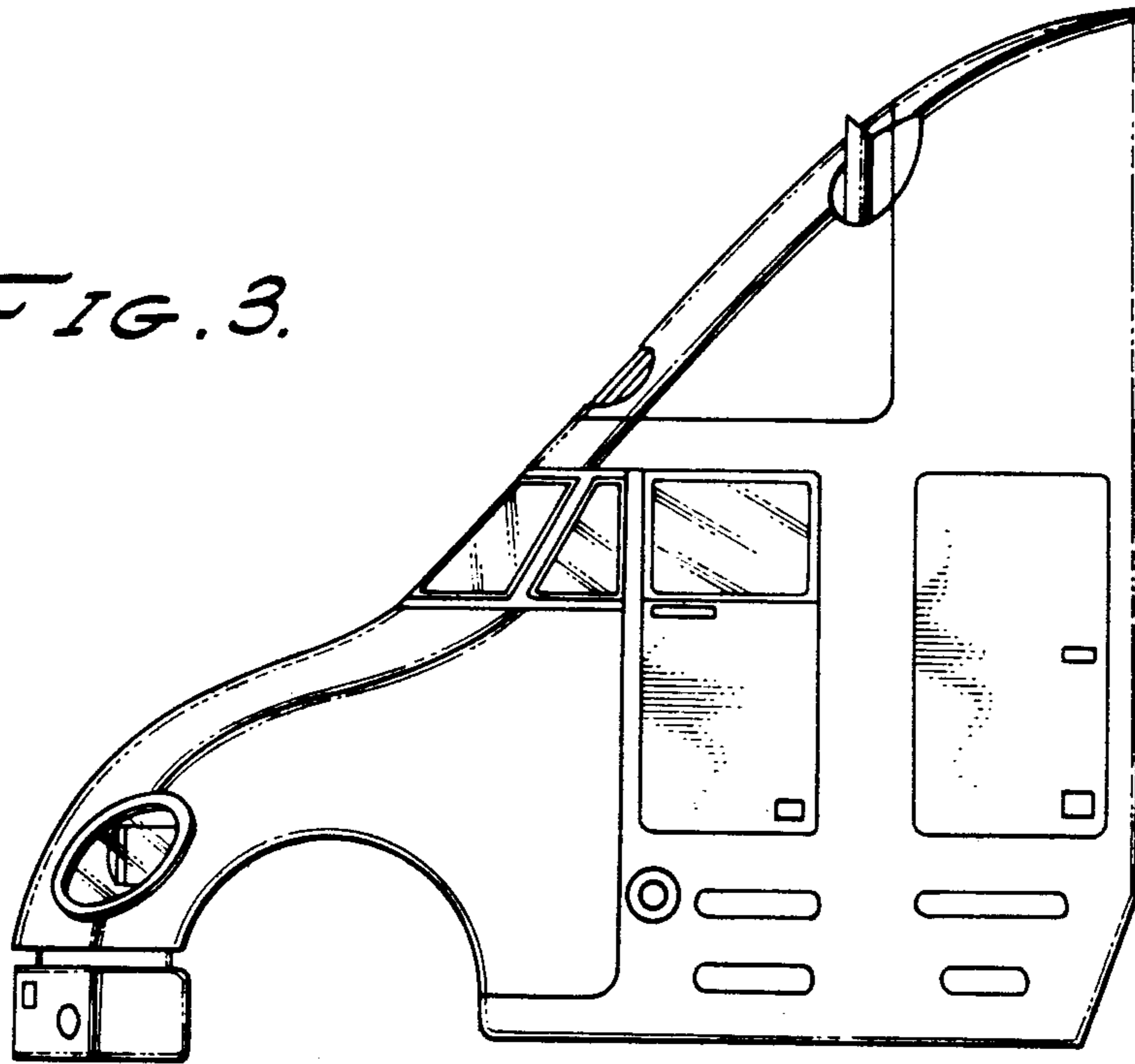

FIG. 4.