

[54] VEHICLE FENDER GUARD

[75] Inventors: James R. Lockwood, Wapakoneta; Joseph A. Ferrante, Toledo, both of Ohio; James P. Olszewski, Temperance, Mich.; John A. Semelka, Maumee, Ohio

[73] Assignee: Lancaster Colony Corporation, Columbus, Ohio

[**] Term: 14 Years

[21] Appl. No.: 846,265

[22] Filed: Oct. 27, 1977

[51] Int. Cl. D12-16

[52] U.S. Cl. D12/185

[58] Field of Search D12/184, 185; 280/154.5 R, 152 R, 159; 298/1 SG

[56] References Cited

U.S. PATENT DOCUMENTS

3,027,178	3/1962	Eaves	280/154.5 R
3,337,238	8/1967	Weasel, Jr.	280/154.5 R

Primary Examiner—James M. Gandy
Attorney, Agent, or Firm—Robert E. Stebens

[57] CLAIM

The ornamental design for a vehicle fender guard, substantially as shown and described.

DESCRIPTION

FIG. 1 is a front perspective view of a vehicle fender guard showing our new design; FIG. 2 is a rear perspective view thereof; FIG. 3 is a front elevational view thereof; FIG. 4 is a right side elevational view thereof; FIG. 5 is a greatly enlarged fragmentary sectional view thereof taken along line 5—5 in FIG. 3; FIG. 6 is a greatly enlarged fragmentary sectional view thereof taken along line 6—6 in FIG. 3; and FIG. 7 is an enlarged sectional view thereof taken along line 7—7 in FIG. 3.

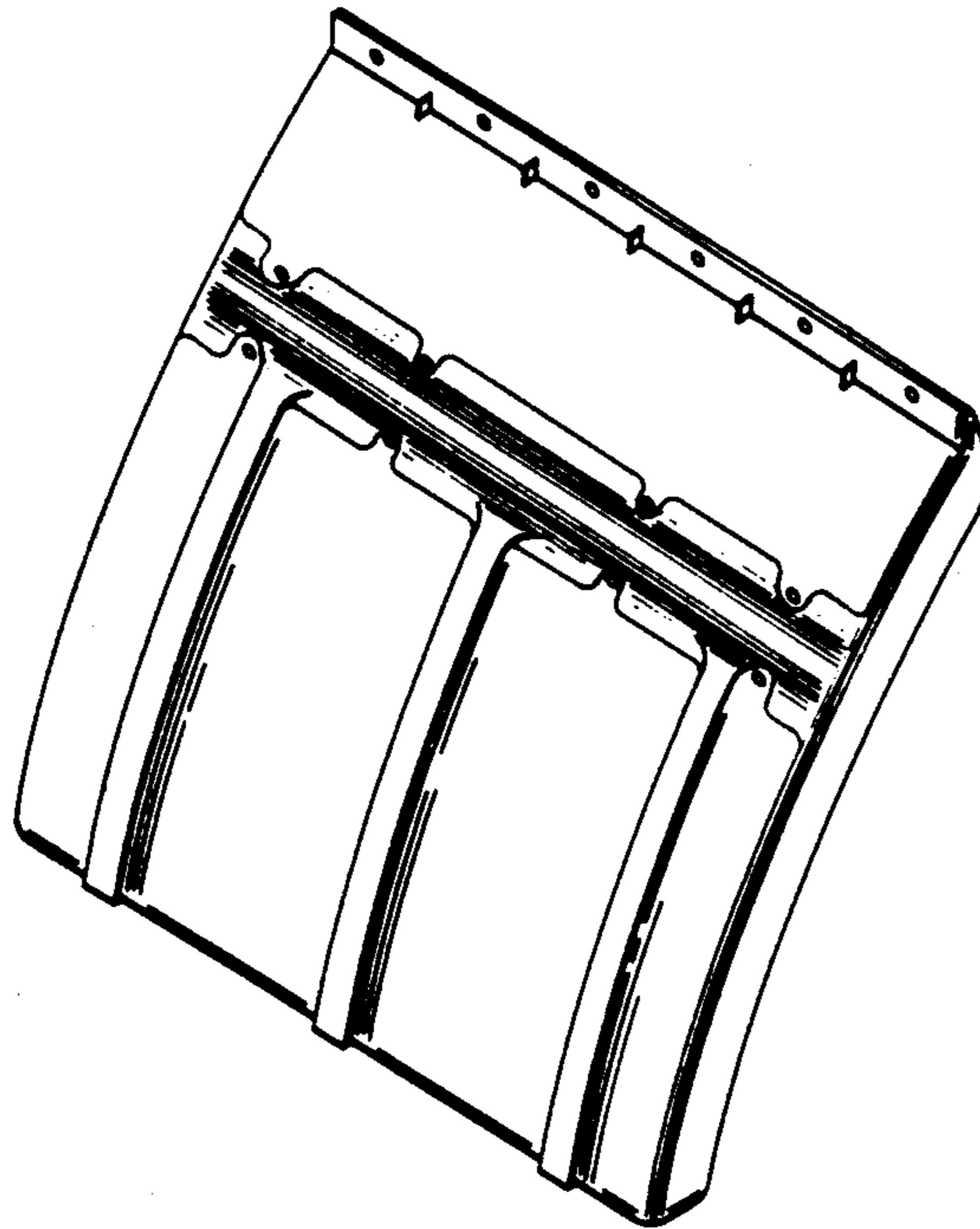

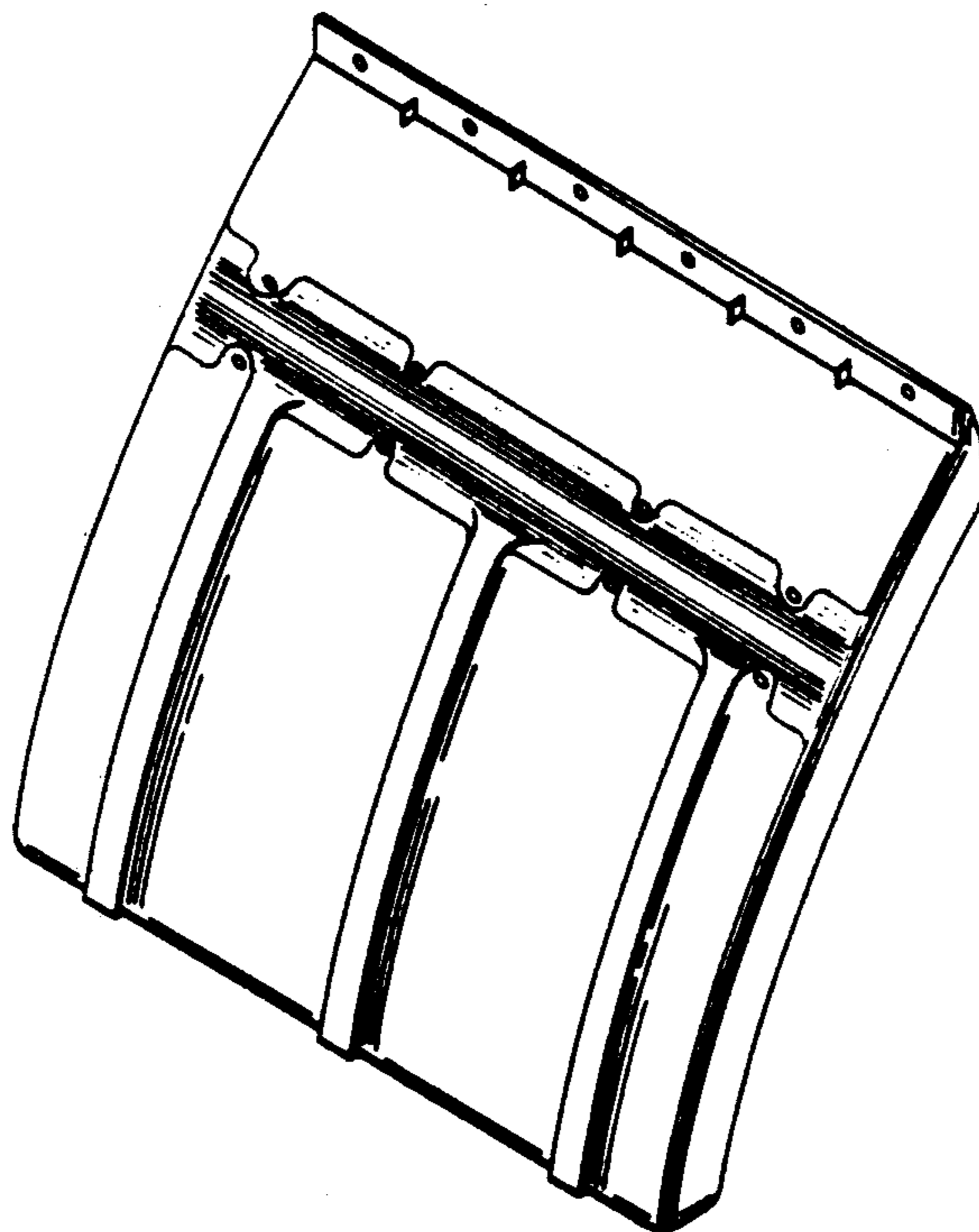

Fig. 1

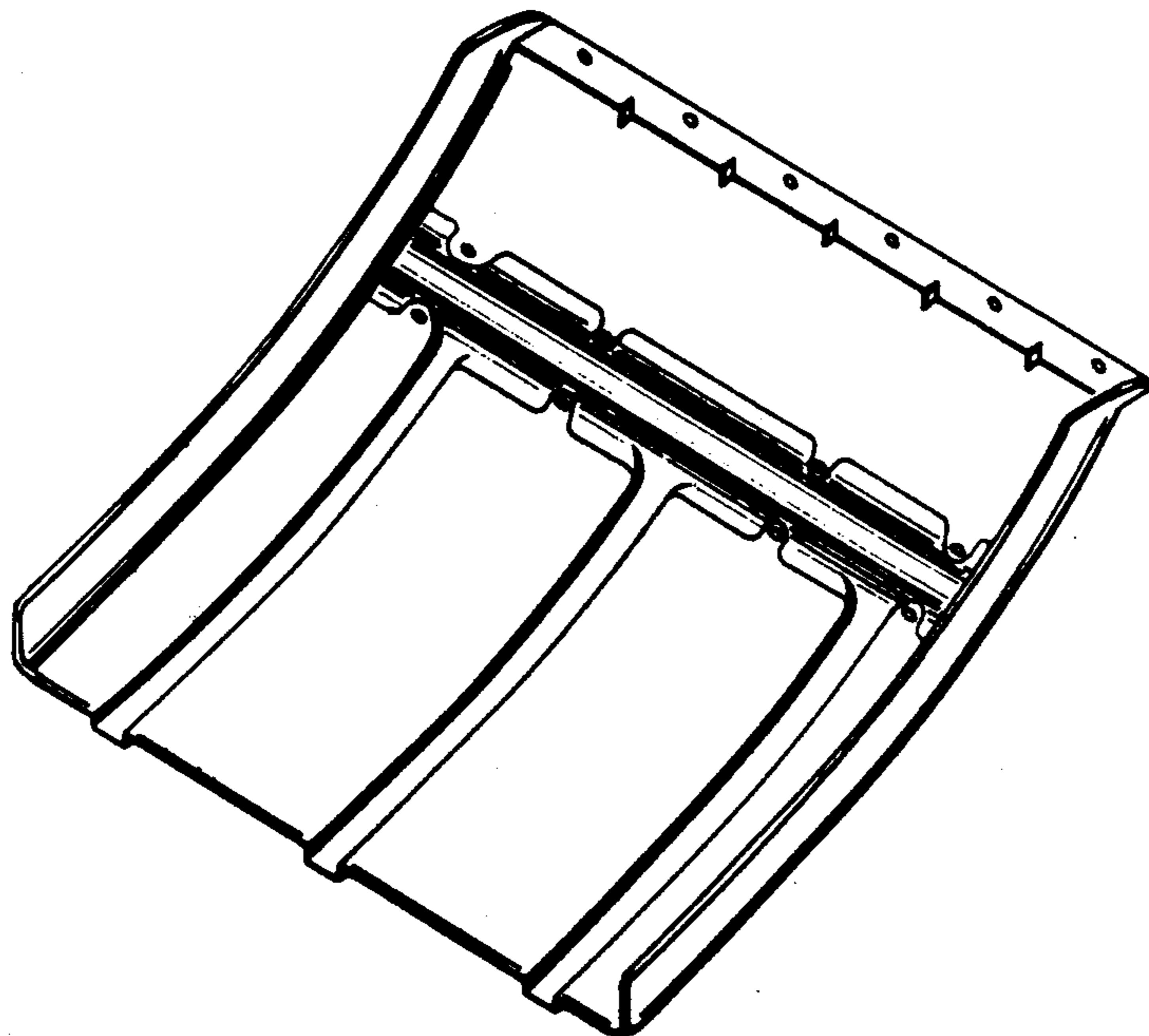

Fig. 2

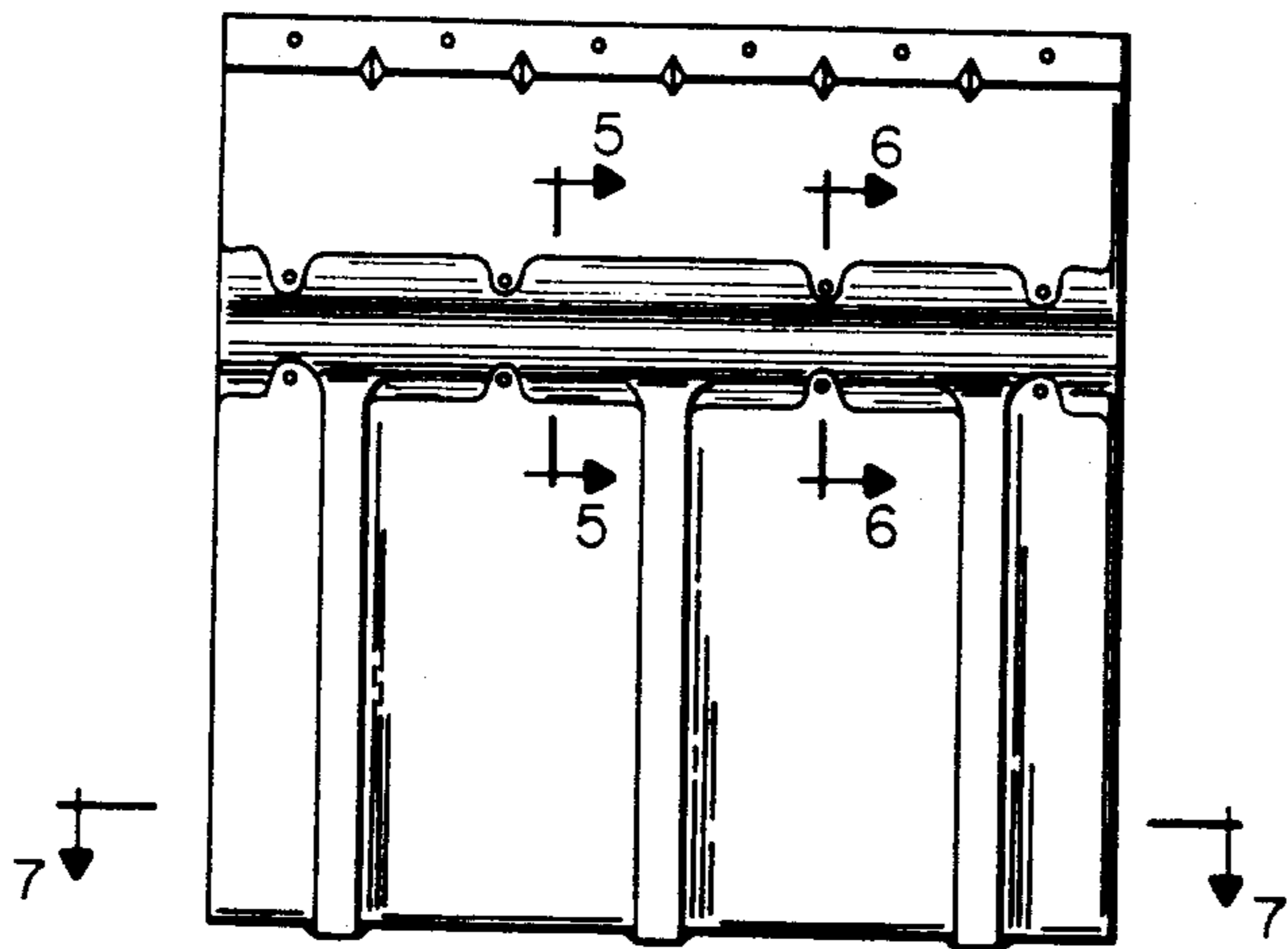

Fig. 3



Fig. 4

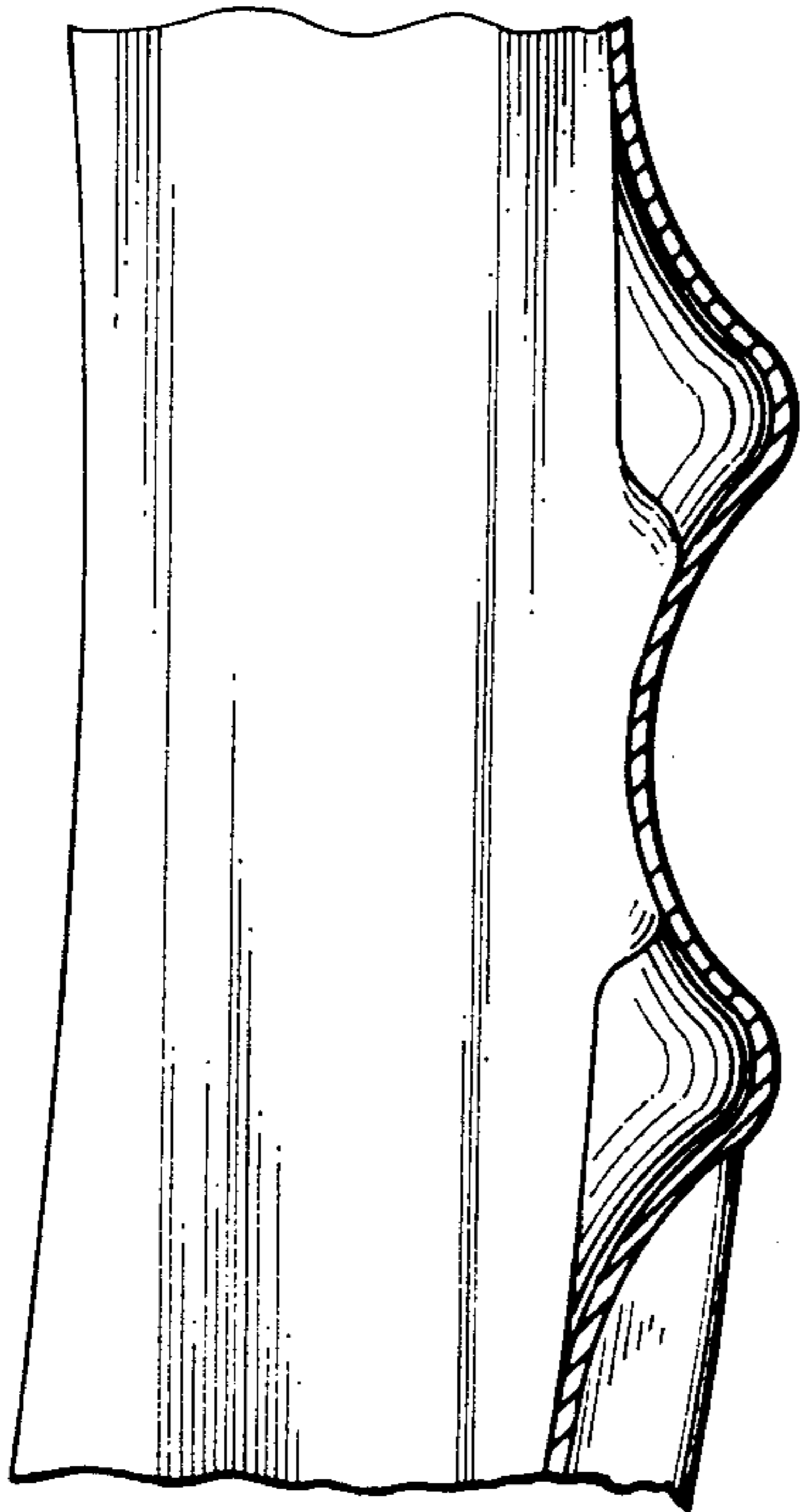

Fig. 5

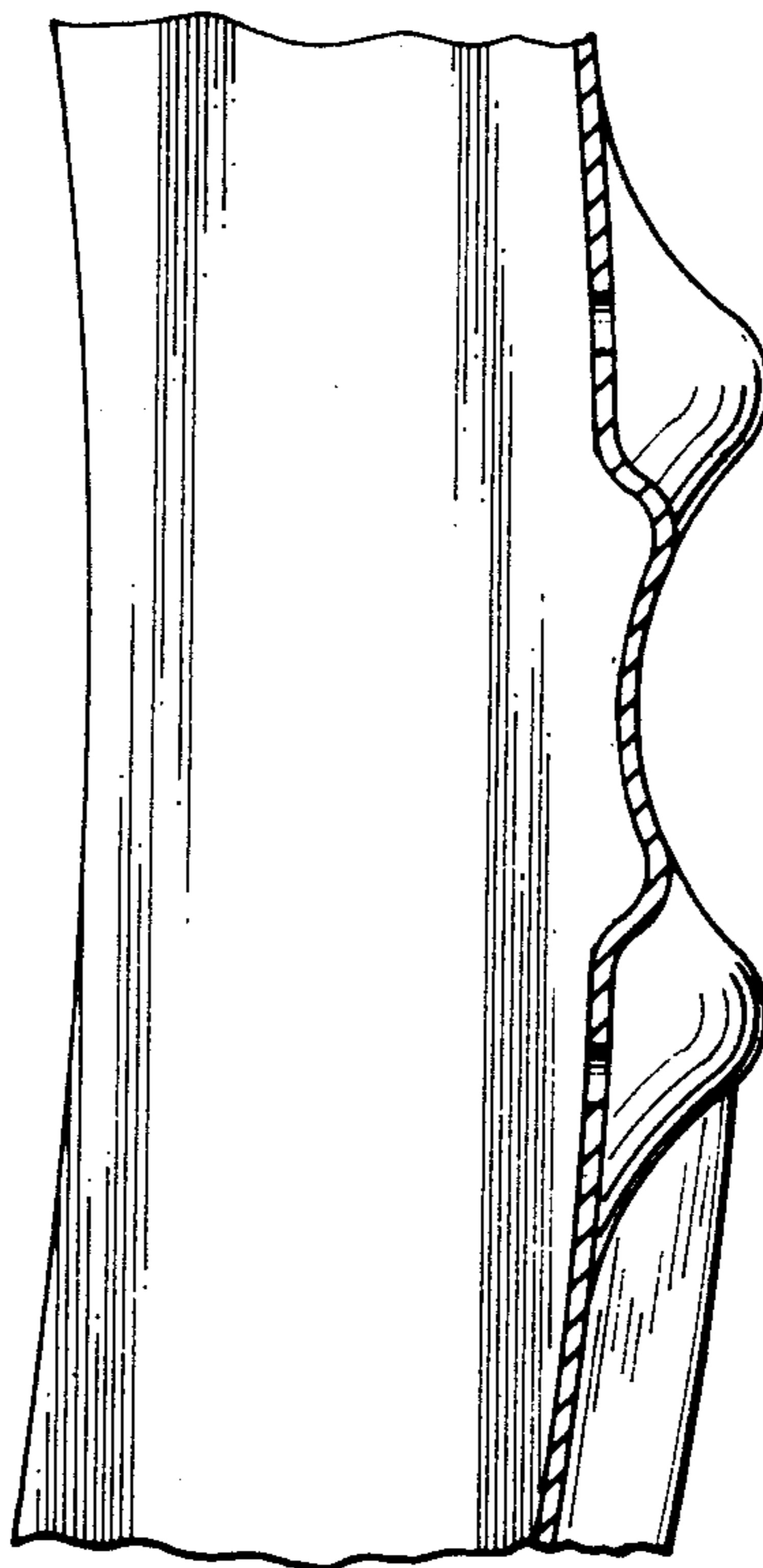

Fig. 6



Fig. 7