

[54] MODEL RACING CAR

[75] Inventor: Robert J. Herd, Milton Malsor, England
[73] Assignee: March Engineering Limited, Bicester, England

[**] Term: 14 Years

[21] Appl. No.: 802,829

[22] Filed: Jun. 2, 1977

[30] Foreign Application Priority Data

Dec. 2, 1976 [GB] United Kingdom 978124/76

[51] Int. Cl. D21-01

[52] U.S. Cl. D21/137

[58] Field of Search D34/15 AJ, 15 AN;
D12/88; 46/103, 105, 201, 202, 204, 206, 210,
211, 212, 213

[56] References Cited

U.S. PATENT DOCUMENTS

D. 222,160	10/1971	Rudd	D12/88
D. 231,544	4/1974	Coppuck	D34/15 AJ
D. 241,960	10/1976	Huffman	D34/15 AJ
D. 246,613	12/1977	Ogawa	D34/15 AJ
4,005,543	9/1975	McKay	46/202

Primary Examiner—Joel Stearman
Assistant Examiner—Charles A. Rademaker
Attorney, Agent, or Firm—Walter Kruger

[57] CLAIM

The ornamental design for a model racing car, as shown and described.

DESCRIPTION

FIG. 1 is a front perspective view of a model racing car showing my new design;

FIG. 2 is a left side perspective view thereof, the right side being a substantial mirror image of the left side shown herein;

FIG. 3 is a front perspective view thereof shown on an enlarged scale; and

FIG. 4 is a rear perspective view thereof.

The bottom of the model racing car is substantially plain and unadorned.

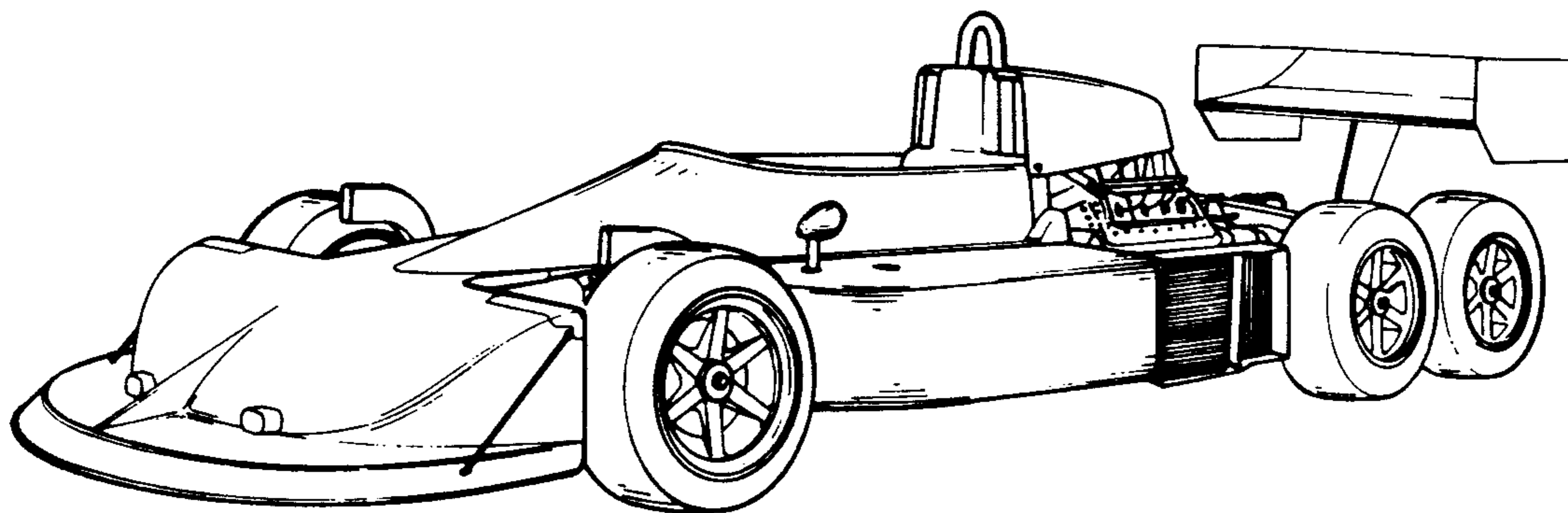

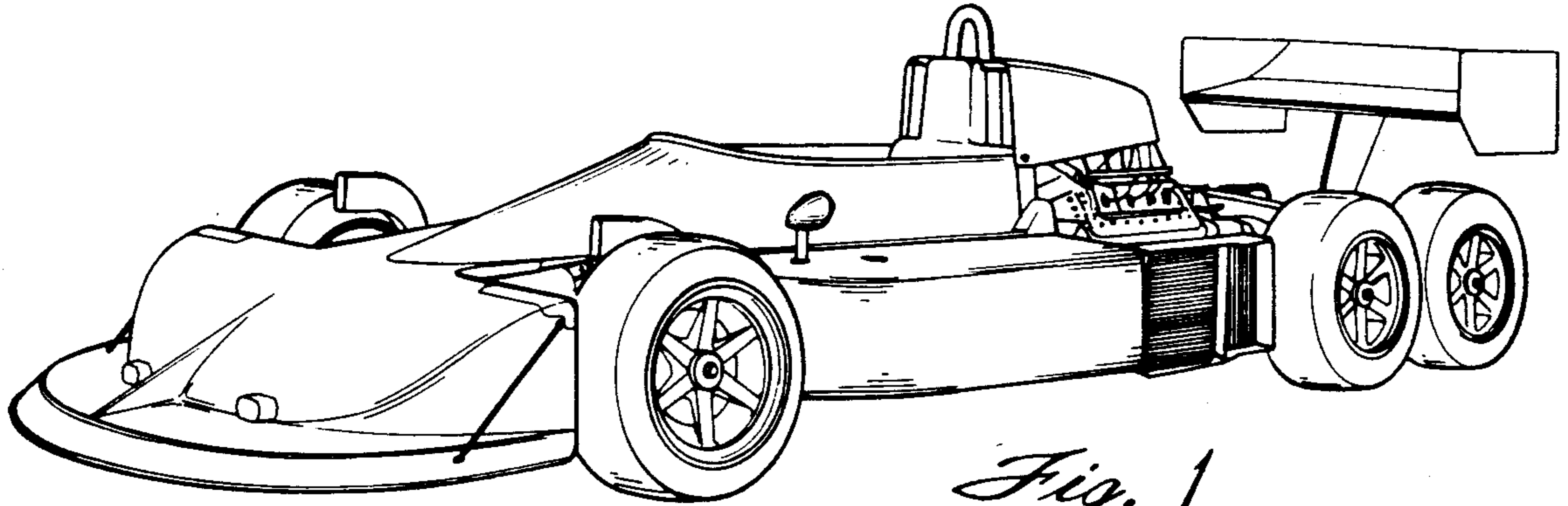

Fig. 1

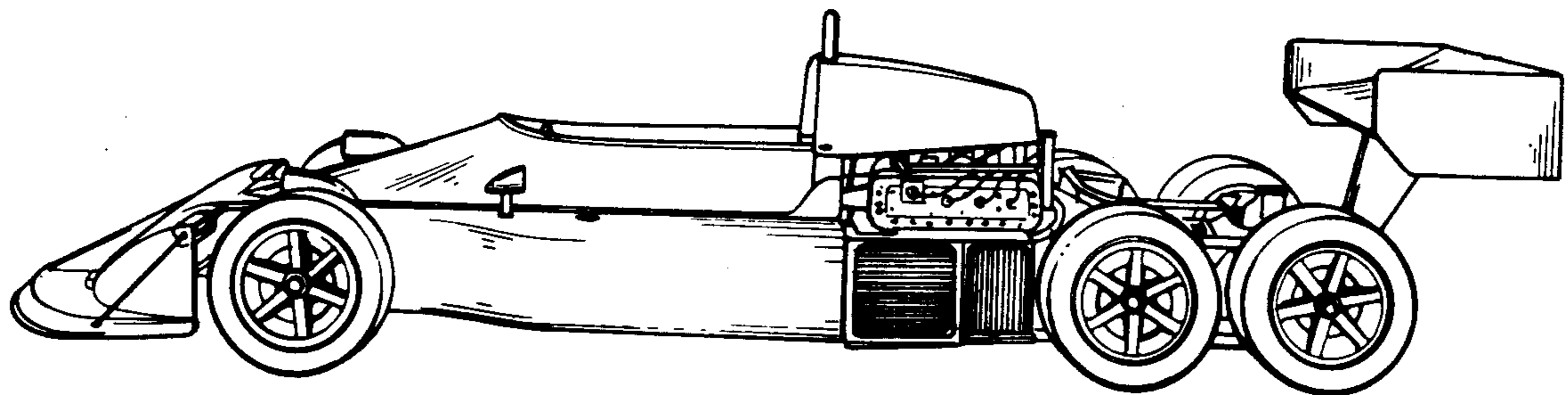

Fig. 2

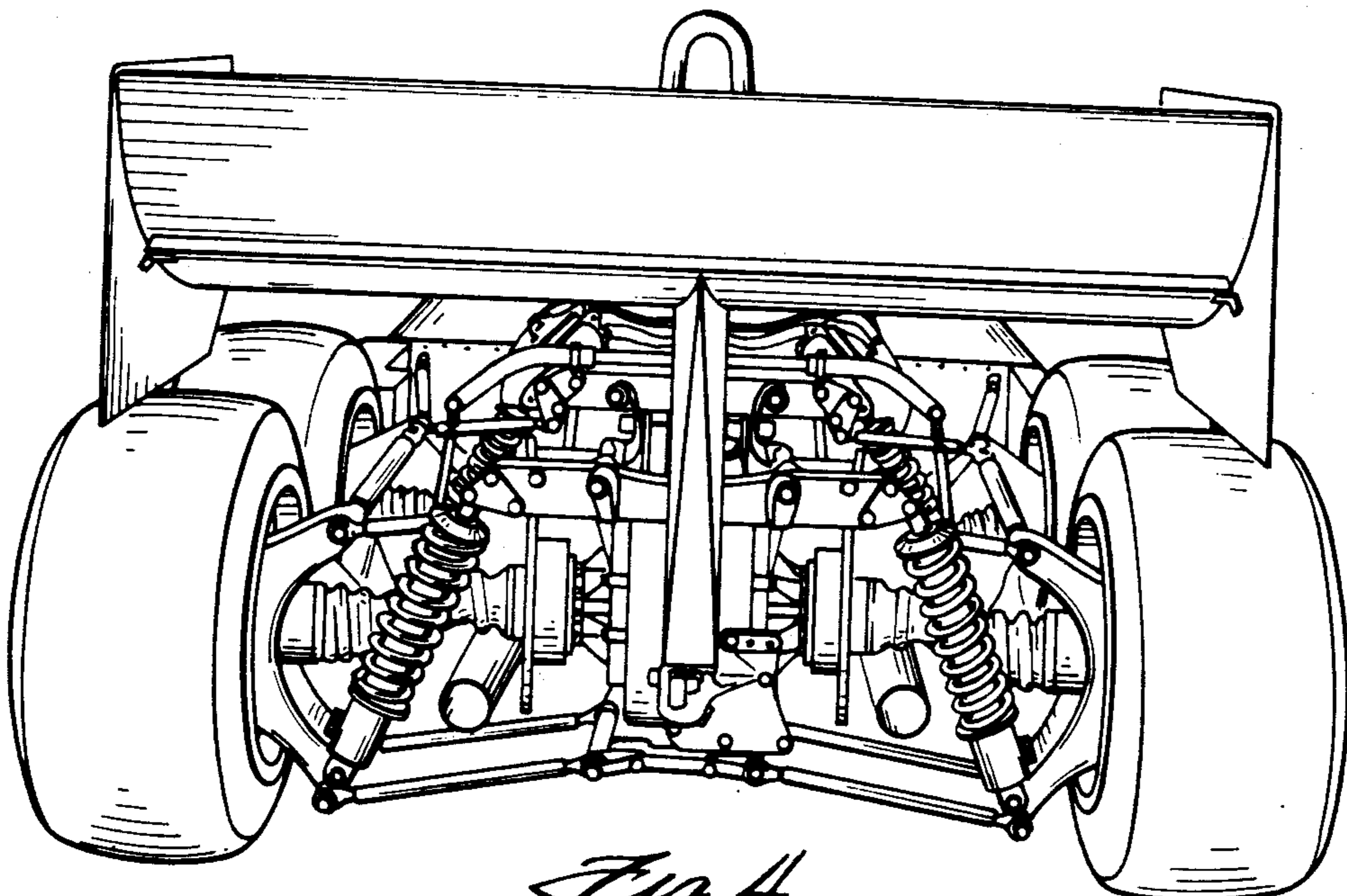

Fig. 4

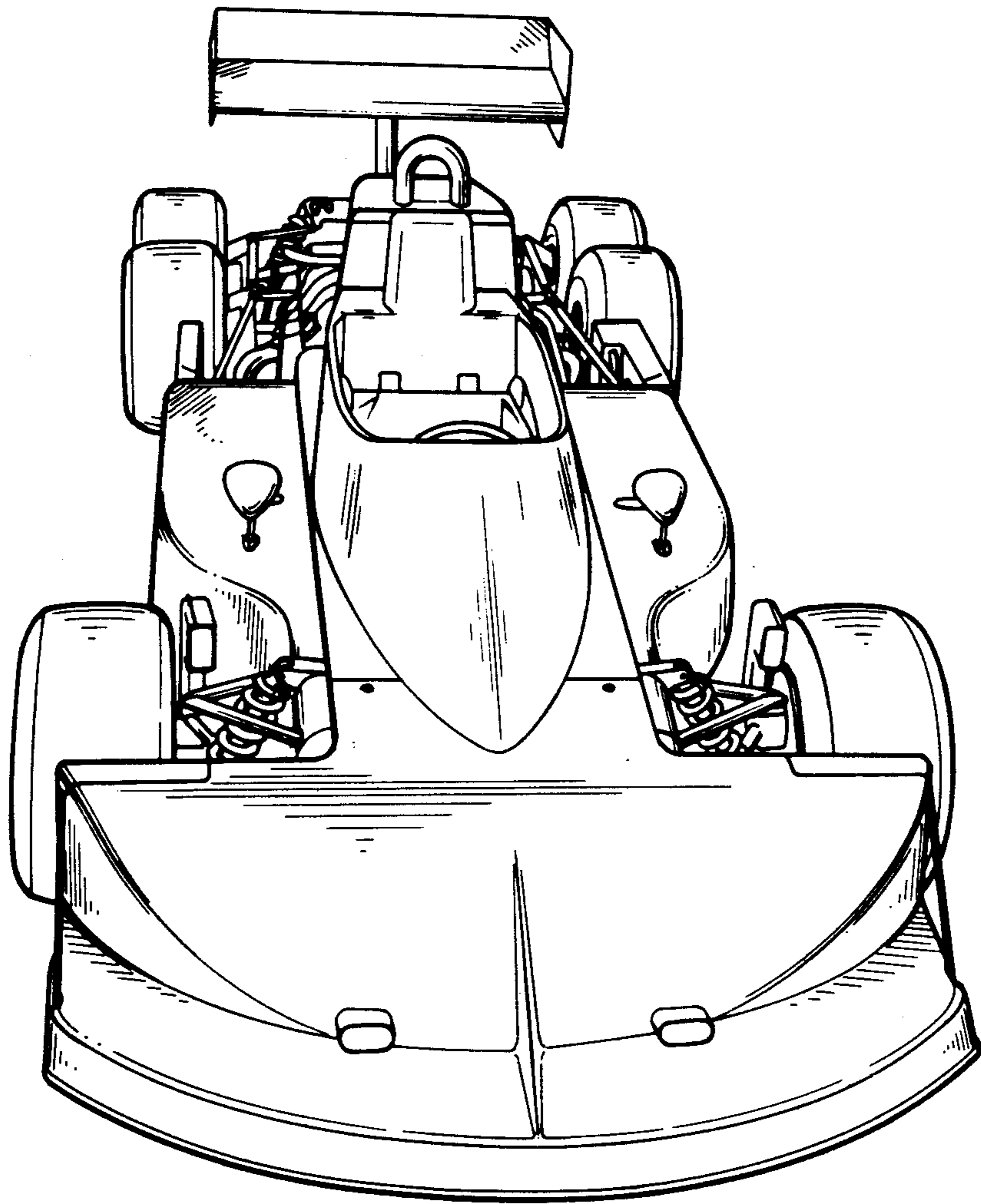

Fig. 3