

[54] TRICYCLE

[75] Inventor: Robert D. Perkins, Toronto, Canada

[73] Assignee: Willowdale Handcar and Wagon Works Ltd., Toronto, Canada

[**] Term: 14 Years

[21] Appl. No.: 936,572

[22] Filed: Aug. 22, 1978

[51] Int. Cl. D12-11

[52] U.S. Cl. D12/112

[58] Field of Search D12/112, 113; 280/261, 280/274, 282, 259, 266

[56]

References Cited

U.S. PATENT DOCUMENTS

3,429,584 2/1969 Hendricks 280/261

FOREIGN PATENT DOCUMENTS

2164 of 1880 United Kingdom 280/261

Primary Examiner—James M. Gandy

Attorney, Agent, or Firm—W. L. Hayhurst

[57]

CLAIM

The ornamental design for a tricycle, as shown.

DESCRIPTION

FIG. 1 is a top rear perspective view of a tricycle showing my new design

FIG. 2 is a bottom front perspective view thereof; and FIG. 3 is a top front perspective view thereof.

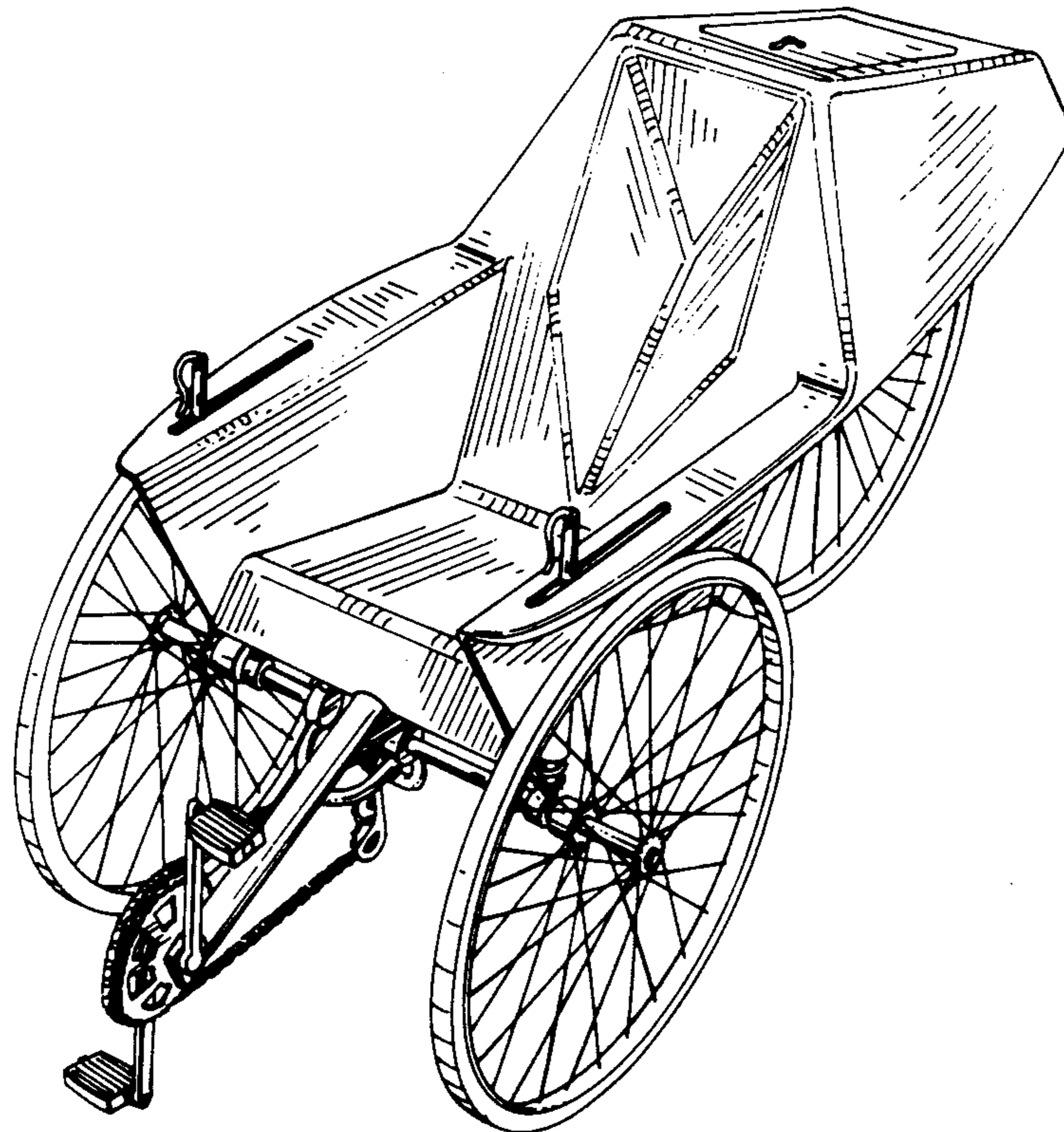

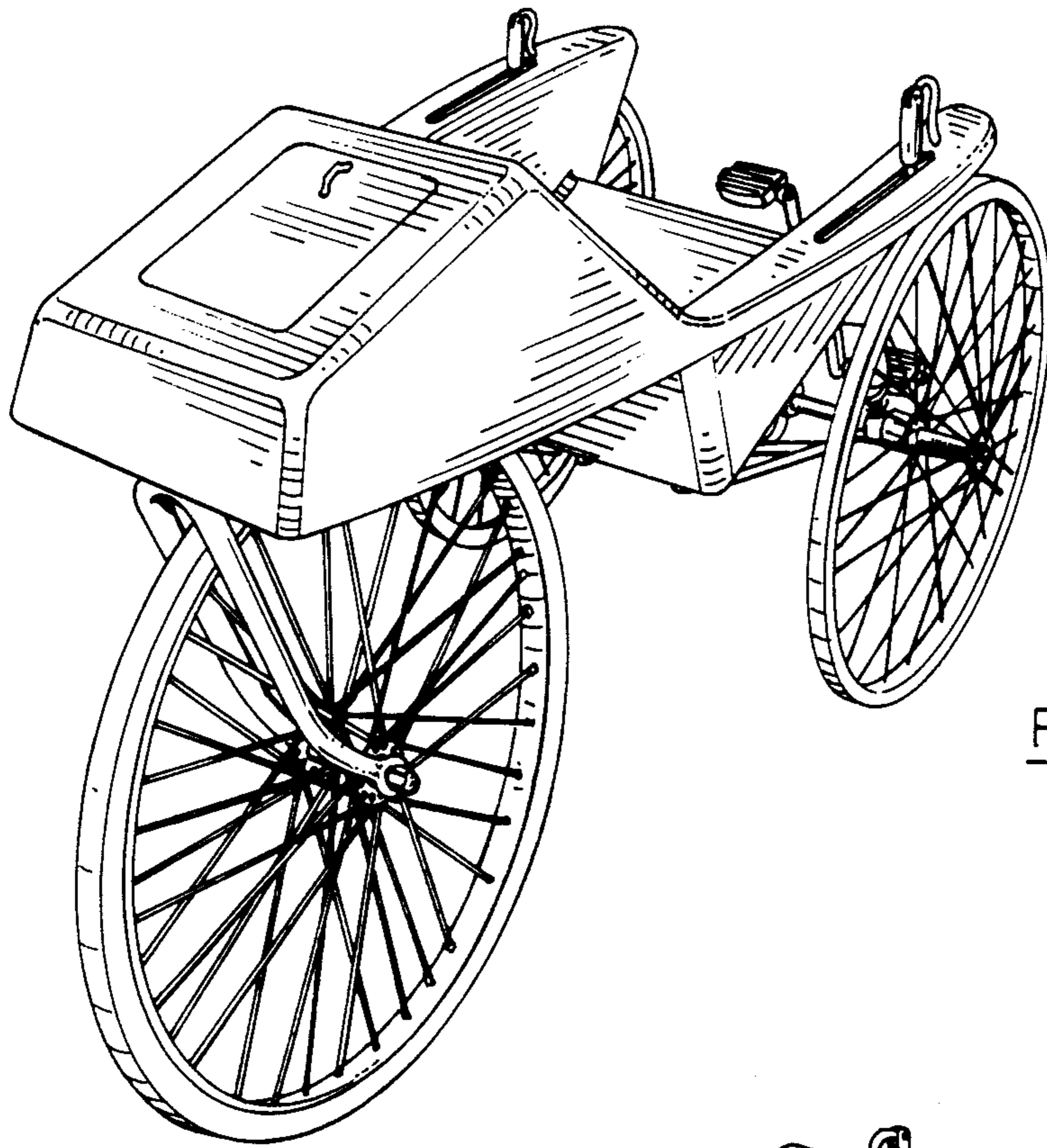

FIG. 1

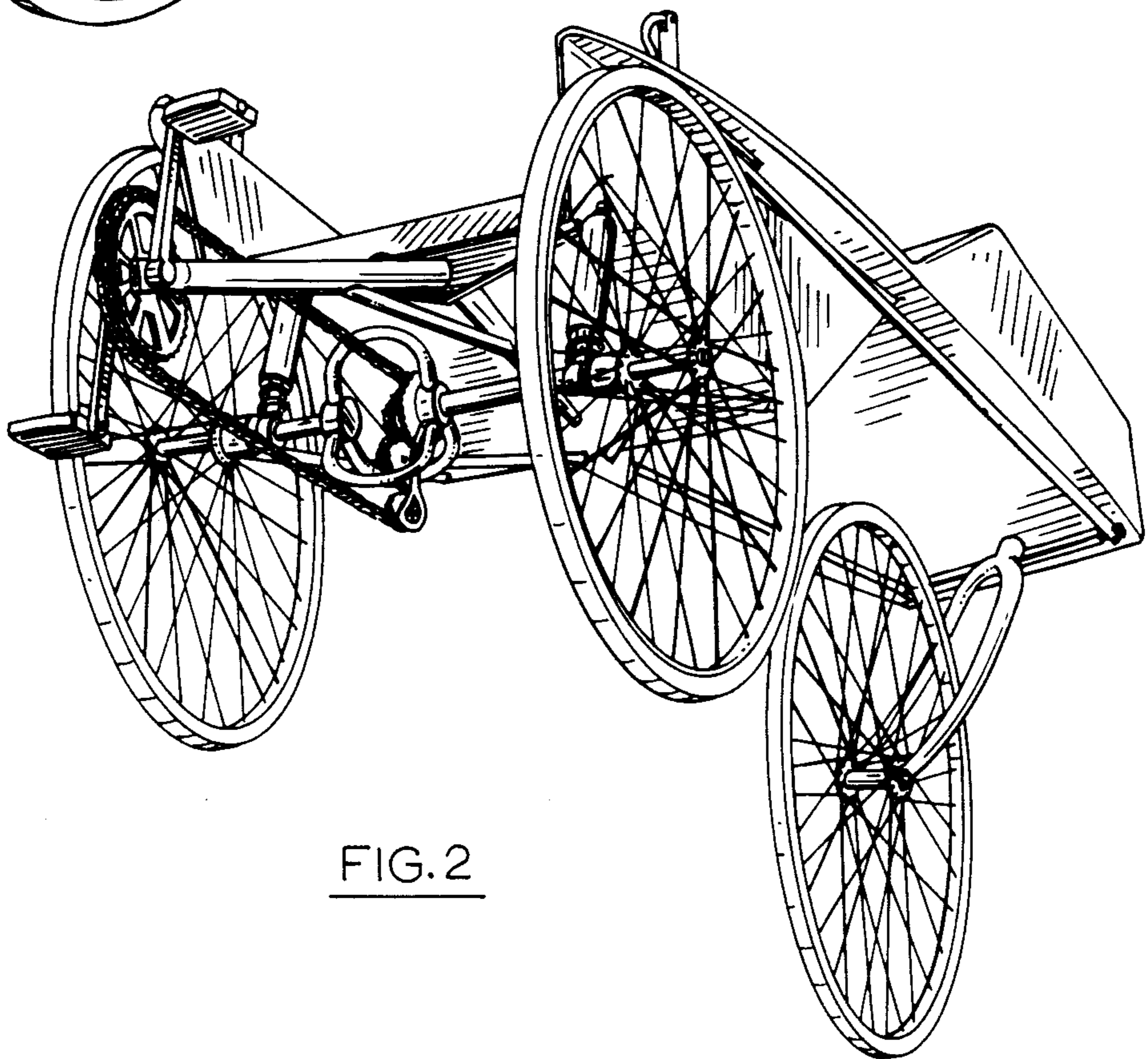

FIG. 2

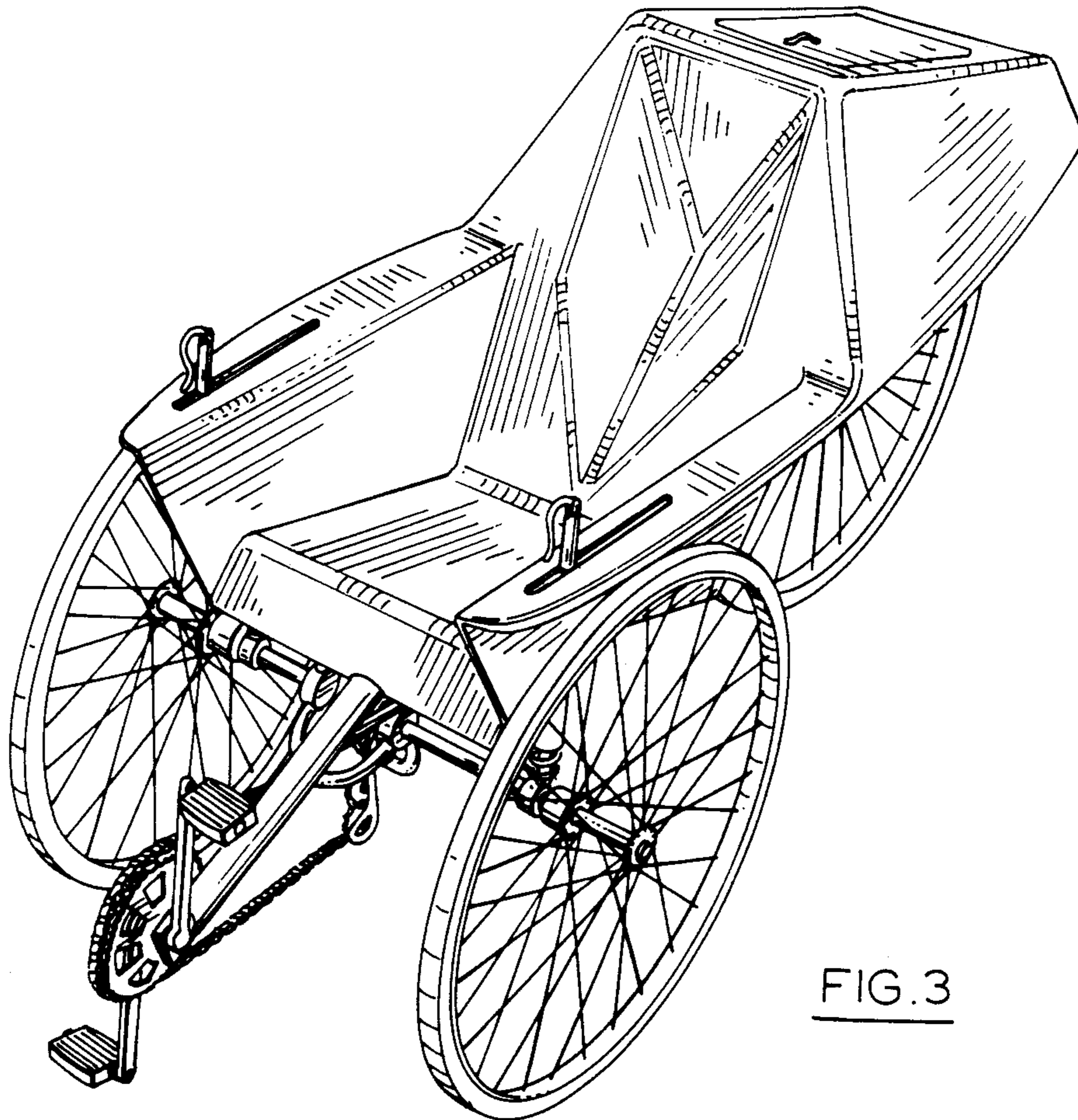

FIG. 3