

[54] SEALING STRIPE FOR A LEVEL CROSSING BETWEEN A ROAD AND A RAILROAD

3,213,768 10/1965 Jensen 404/43
4,018,475 4/1977 Richtermeier 296/28 R

[75] Inventors: Sten Limmergård, Alvesta; Stig H. G. Thim, Växjö, both of Sweden

Primary Examiner—A. Hugo Word
Attorney, Agent, or Firm—Robert Osann

[73] Assignee: A - Betong AB, Vaxjo, Sweden

[57] CLAIM

[**] Term: 14 Years

The ornamental design for a sealing stripe for a level crossing between a road and a railroad, substantially as shown and described.

[21] Appl. No.: 894,199

[22] Filed: Apr. 6, 1978

DESCRIPTION

[30] Foreign Application Priority Data

Oct. 7, 1977 [SE] Sweden 772011

FIG. 1 is a perspective view of a sealing stripe for a level crossing between a road and a railroad of our design for use adjacent a rail;
FIG. 2 is an end view of the sealing stripe for a level crossing between a road and a railroad of FIG. 1;
FIG. 3 is a bottom view of FIG. 1;
FIG. 4 is a side elevation of the sealing stripe for a level crossing between a road and a railroad of FIG. 1 as seen from the right of FIG. 2;
FIG. 5 is a top view of FIG. 1; and
FIG. 6 is a side elevation of the sealing stripe for a level crossing between a road and a railroad of FIG. 1, as seen from the right of FIG. 1.

[51] Int. Cl. D25—01

[52] U.S. Cl. D25/74; D25/79

[58] Field of Search D25/74, 75, 76, 78, D25/79, 92, 97; 404/18, 34, 43; 296/28 R; D72/49, 50, 57; 238/8, 9, 7, 2, 3, 5, 54

[56] References Cited

U.S. PATENT DOCUMENTS

2,877,515 3/1959 Haas D25/75 X

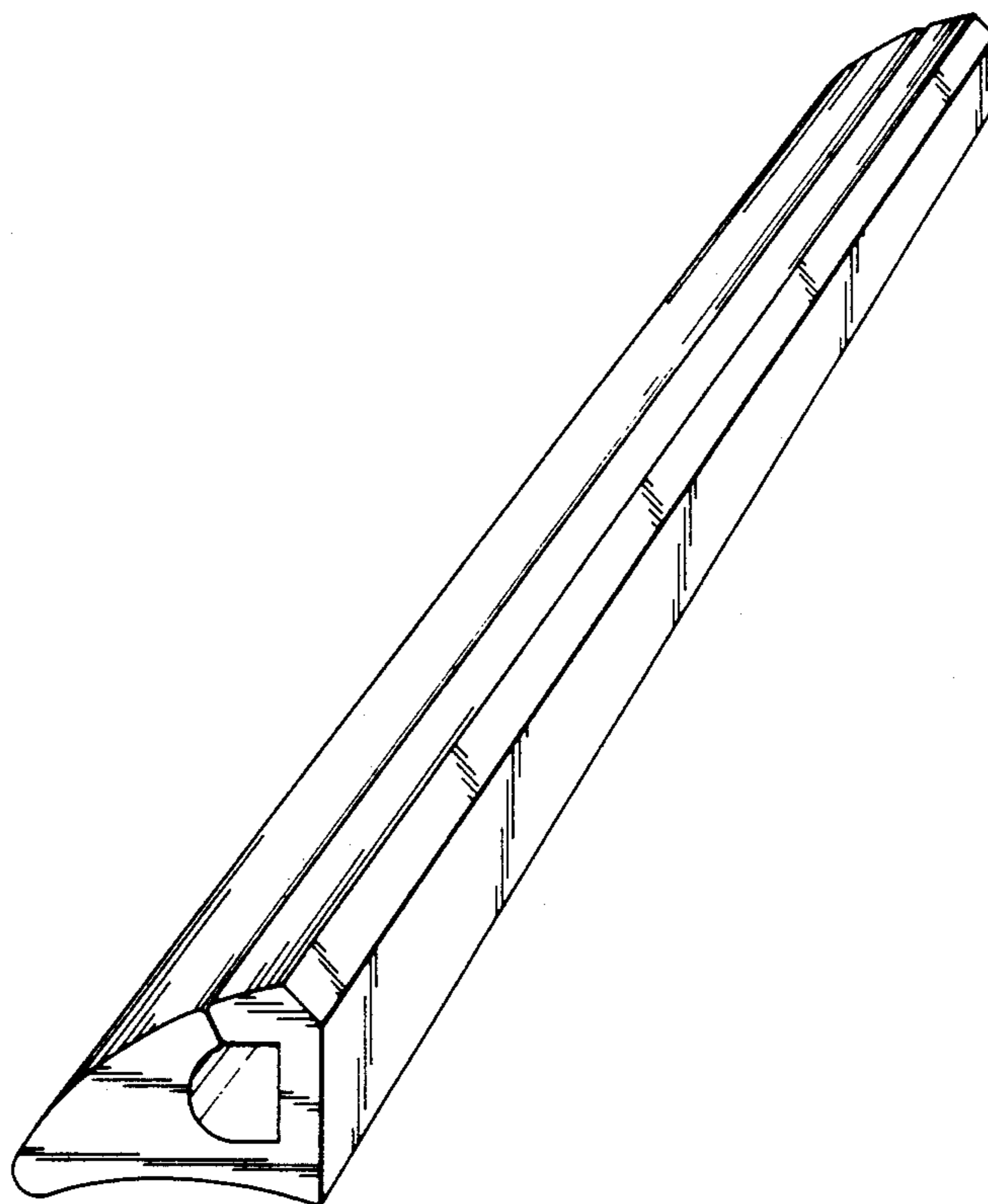

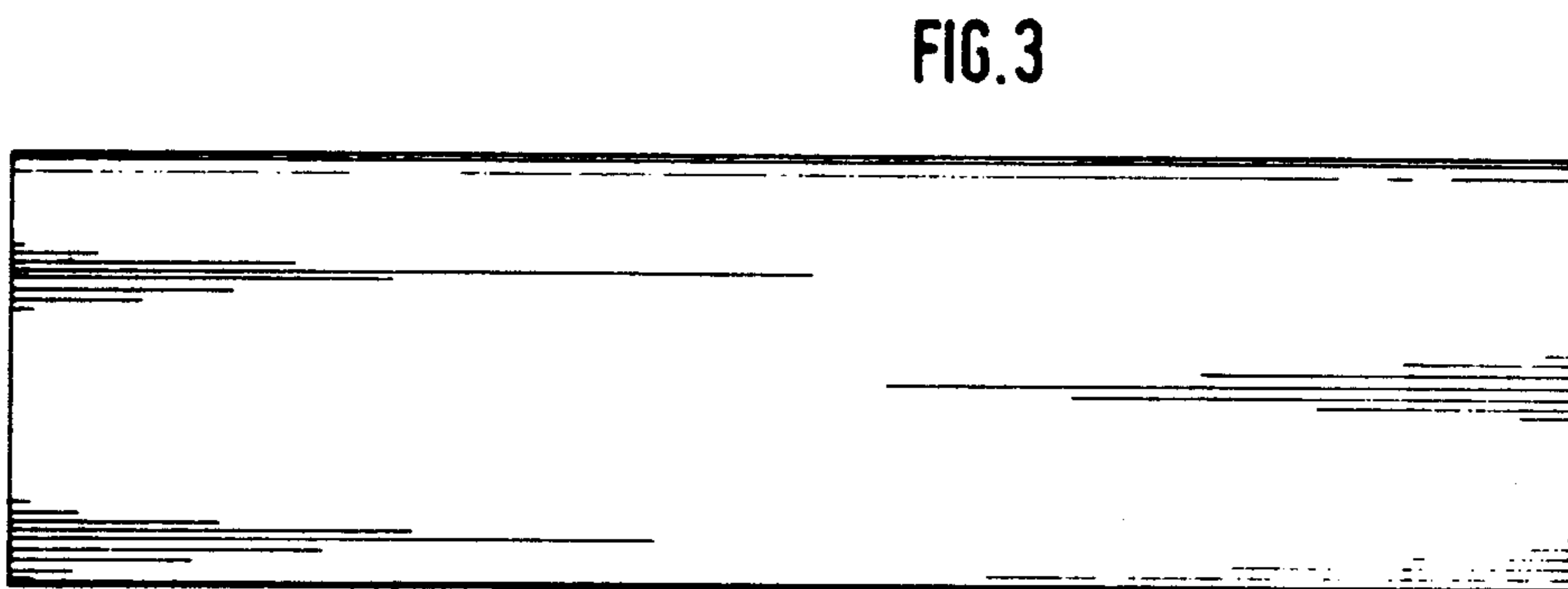
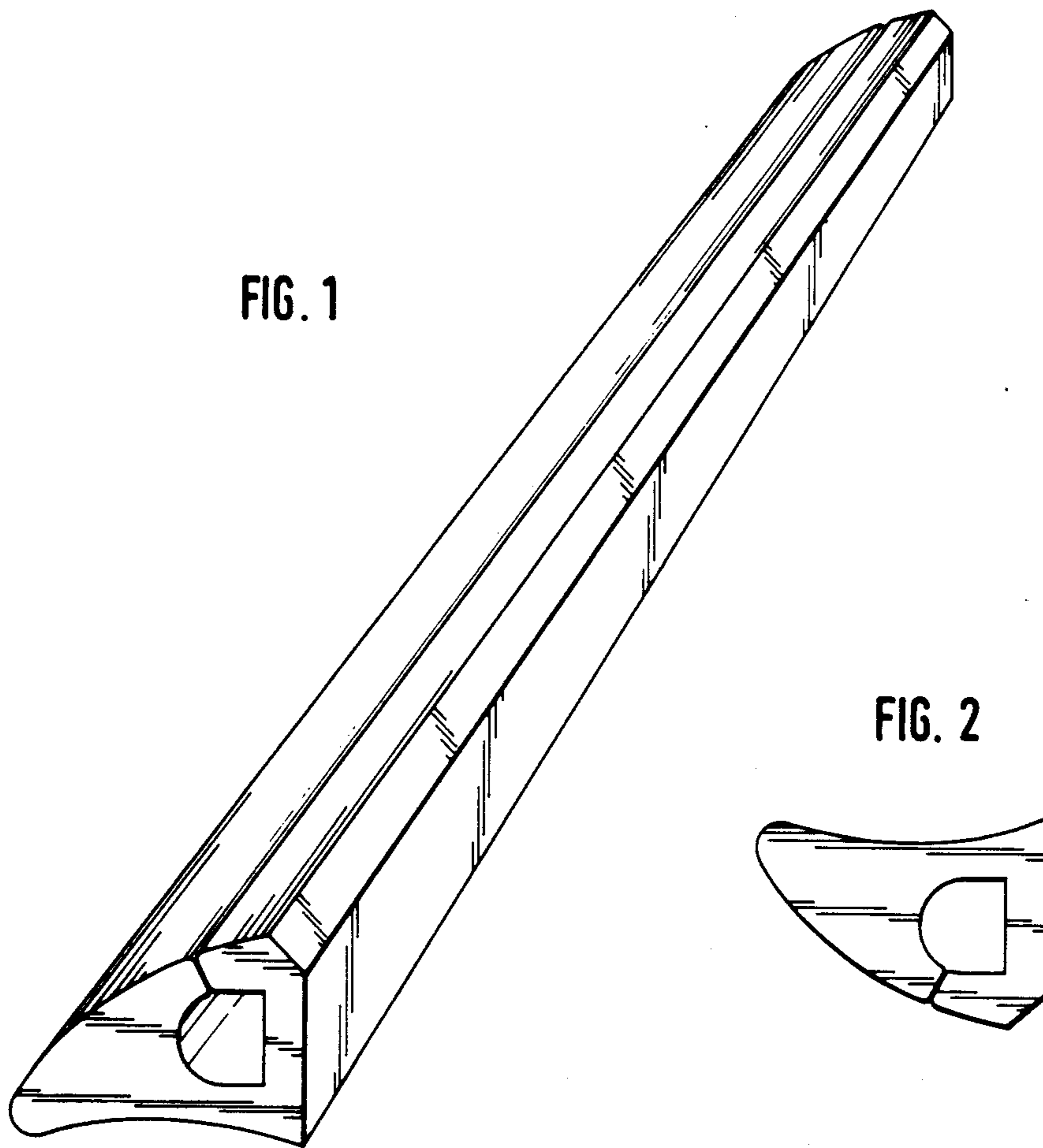

FIG. 4

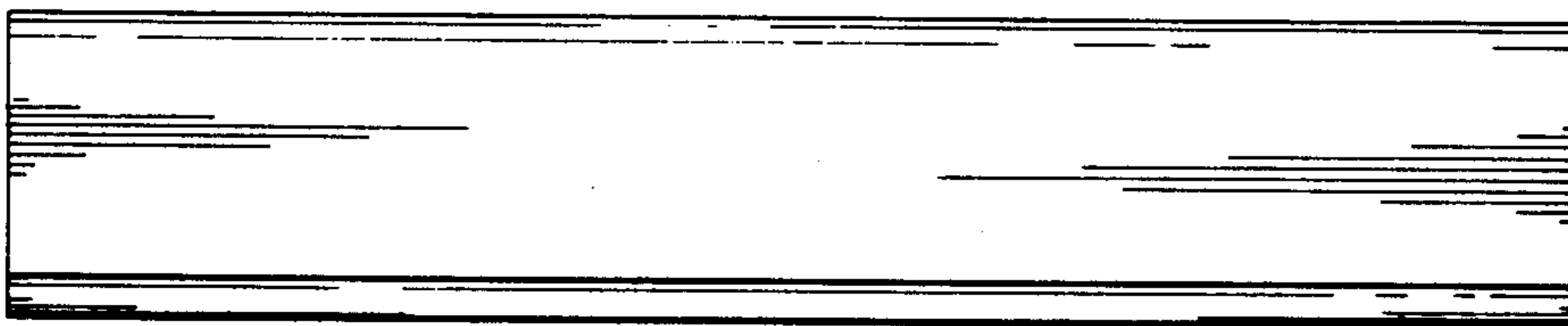

FIG. 5

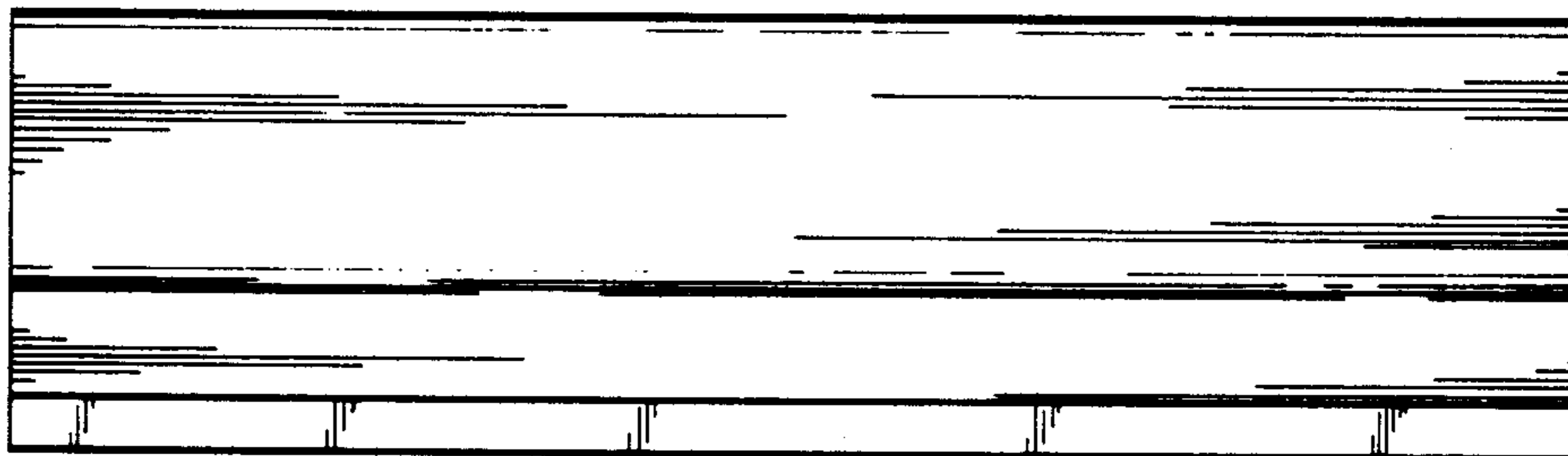

FIG. 6

