

[54] VEHICLE TIRE

[75] Inventors: Sakae Ezura, Matsudo; Hiroshi Kojima, Hino, both of Japan

[73] Assignee: Bridgestone Tire Company Limited, Tokyo, Japan

[**] Term: 14 Years

[21] Appl. No.: 927,433

[22] Filed: Jul. 24, 1978

[30] Foreign Application Priority Data

Feb. 13, 1978 [JP] Japan 53-4581

[51] Int. Cl. D12-15

[52] U.S. Cl. D12/147

[58] Field of Search D12/141-143, D12/146-151, 134; 152/209 R, 209 B, 209 D, DIG. 3

[56] References Cited

PUBLICATIONS

Tire Review, 4/76, P25, Tire, bottom right side of page. Modern Tire Dealer, 9/76, P87, Cat Trac 11-15 Tire, lower right side of page.

Primary Examiner—James M. Gandy
Attorney, Agent, or Firm—Richard C. Sughrue

[57] CLAIM

The ornamental design for a vehicle tire, as shown and described.

DESCRIPTION

FIG. 1 is an end elevational view of a vehicle tire showing our new design;

FIG. 2 is a side elevational view thereof;

FIG. 3 is a perspective view thereof;

FIG. 4 is an enlarged fragmentary developed plan view of the tread design thereof; and

FIG. 5 is an enlarged cross sectional view thereof taken along the line 5-5 in FIG. 4.

It is to be understood that the tread design is repeated throughout the circumference of the tire, and the opposite side is the same as that shown.

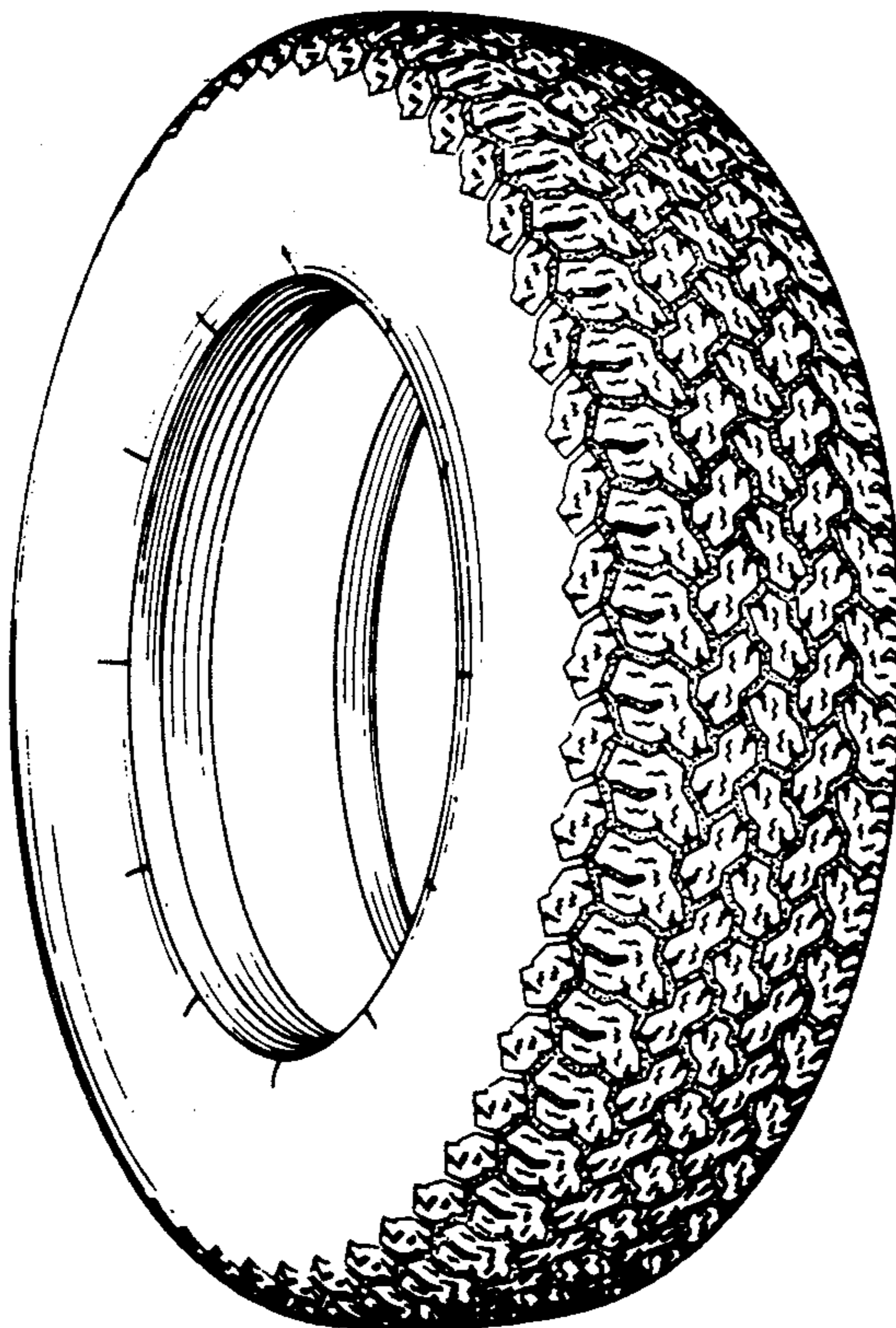

FIG. 1

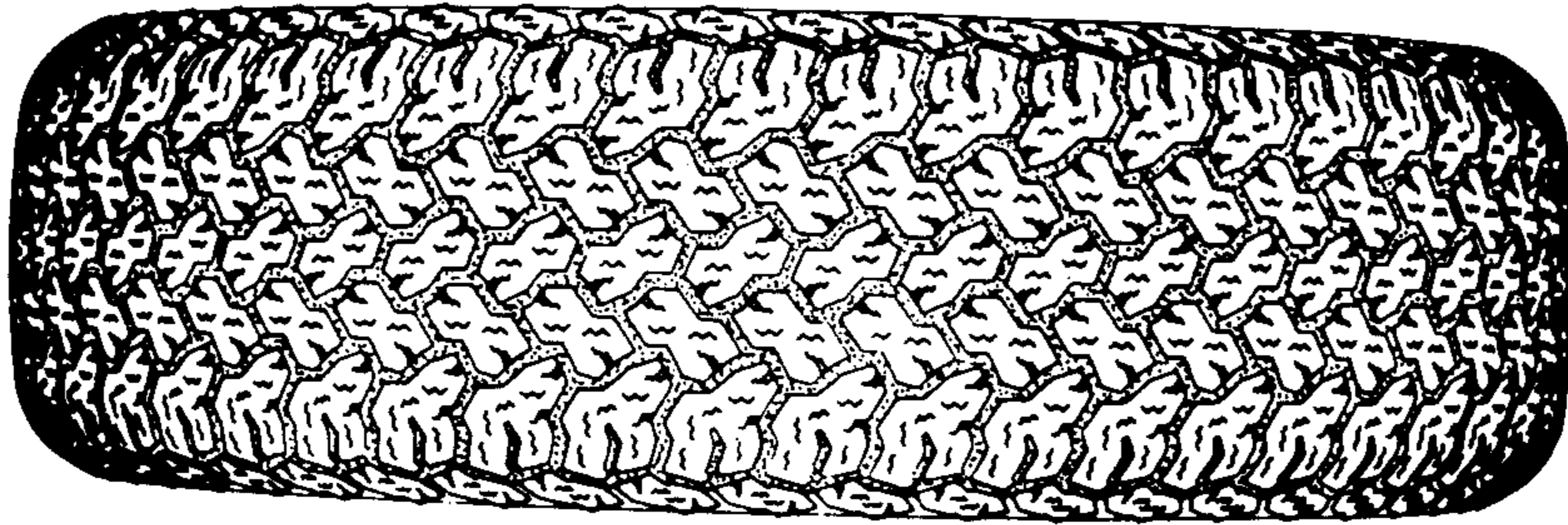

FIG. 2

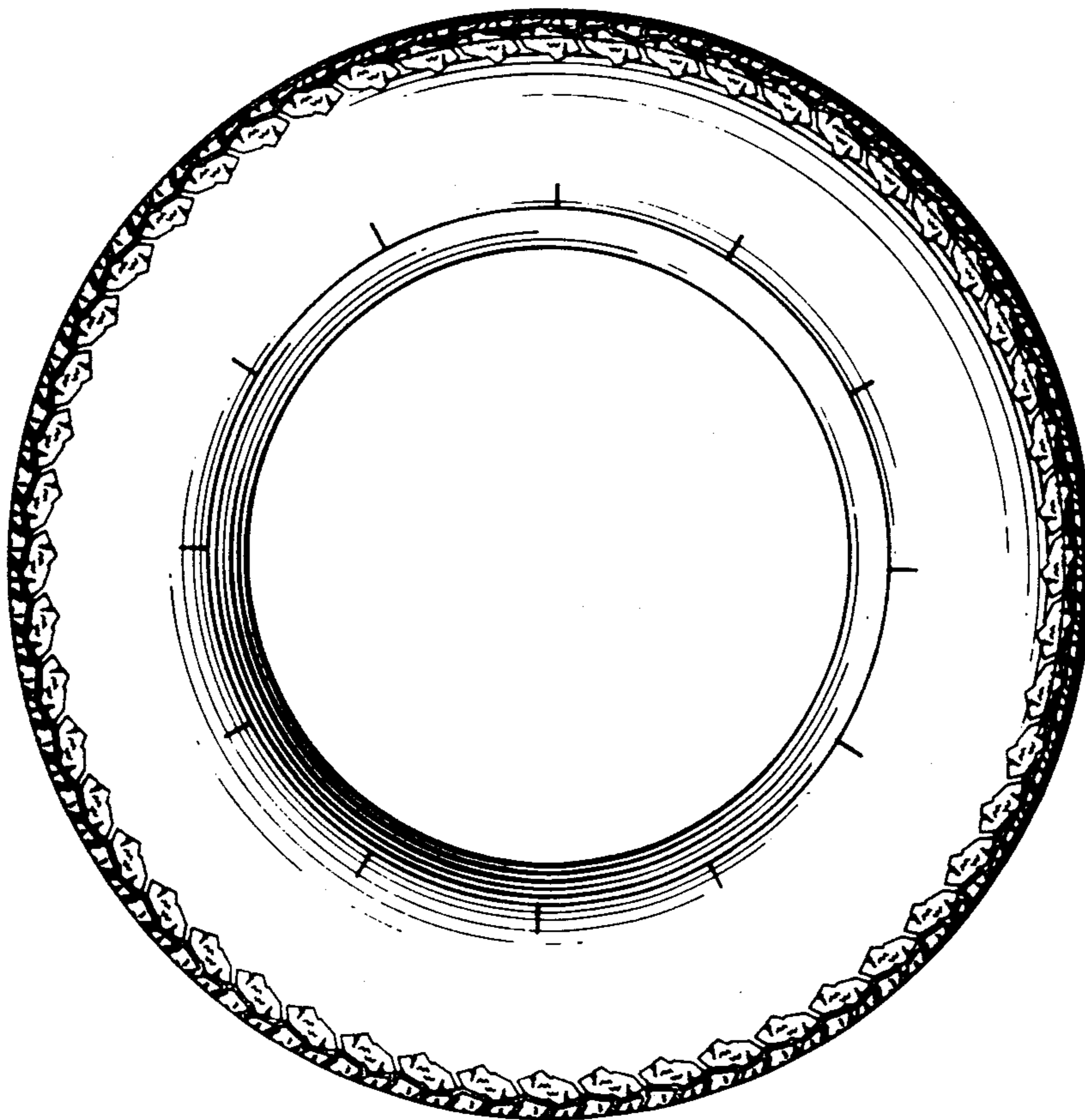

FIG. 4

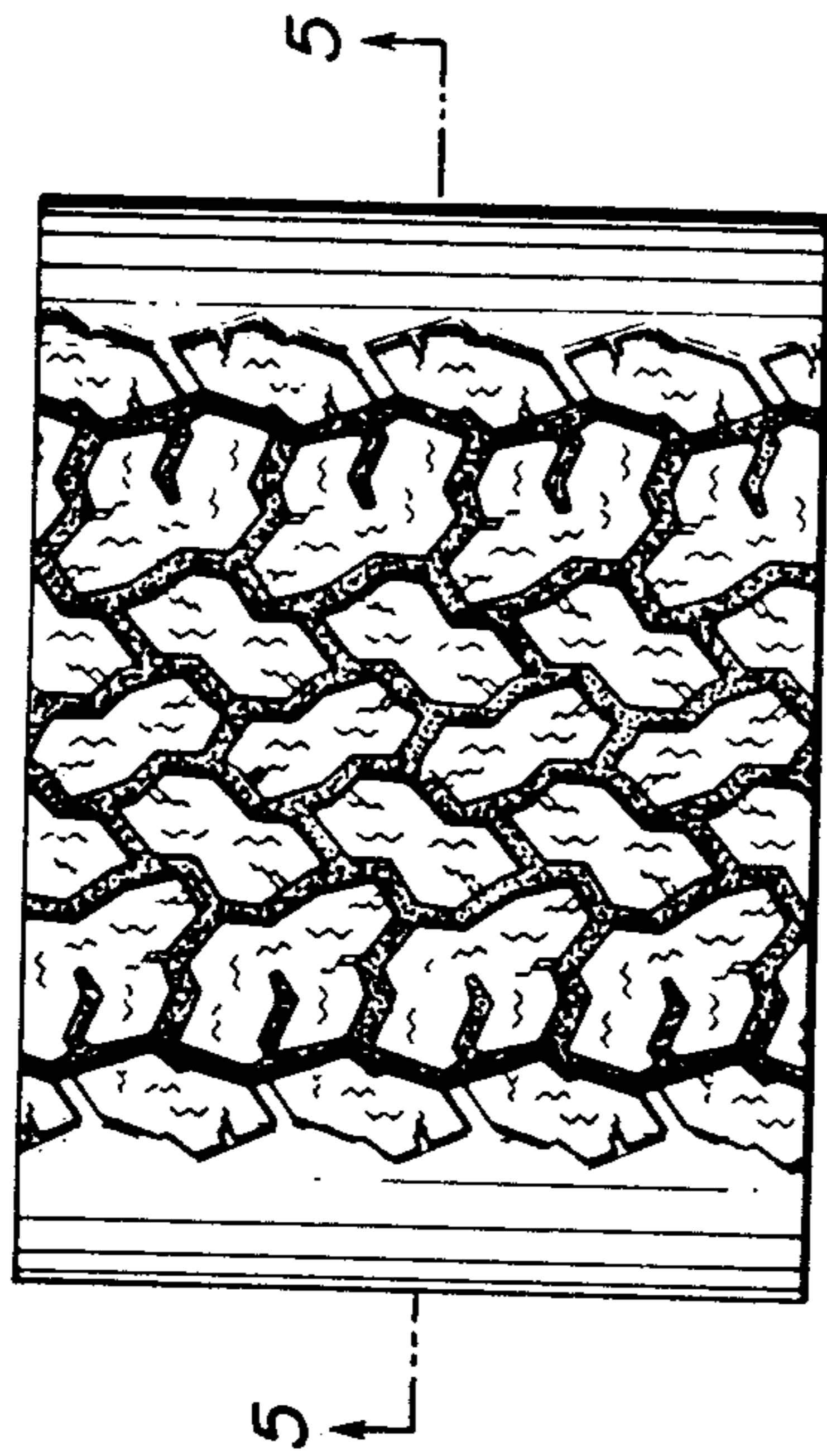

FIG. 5

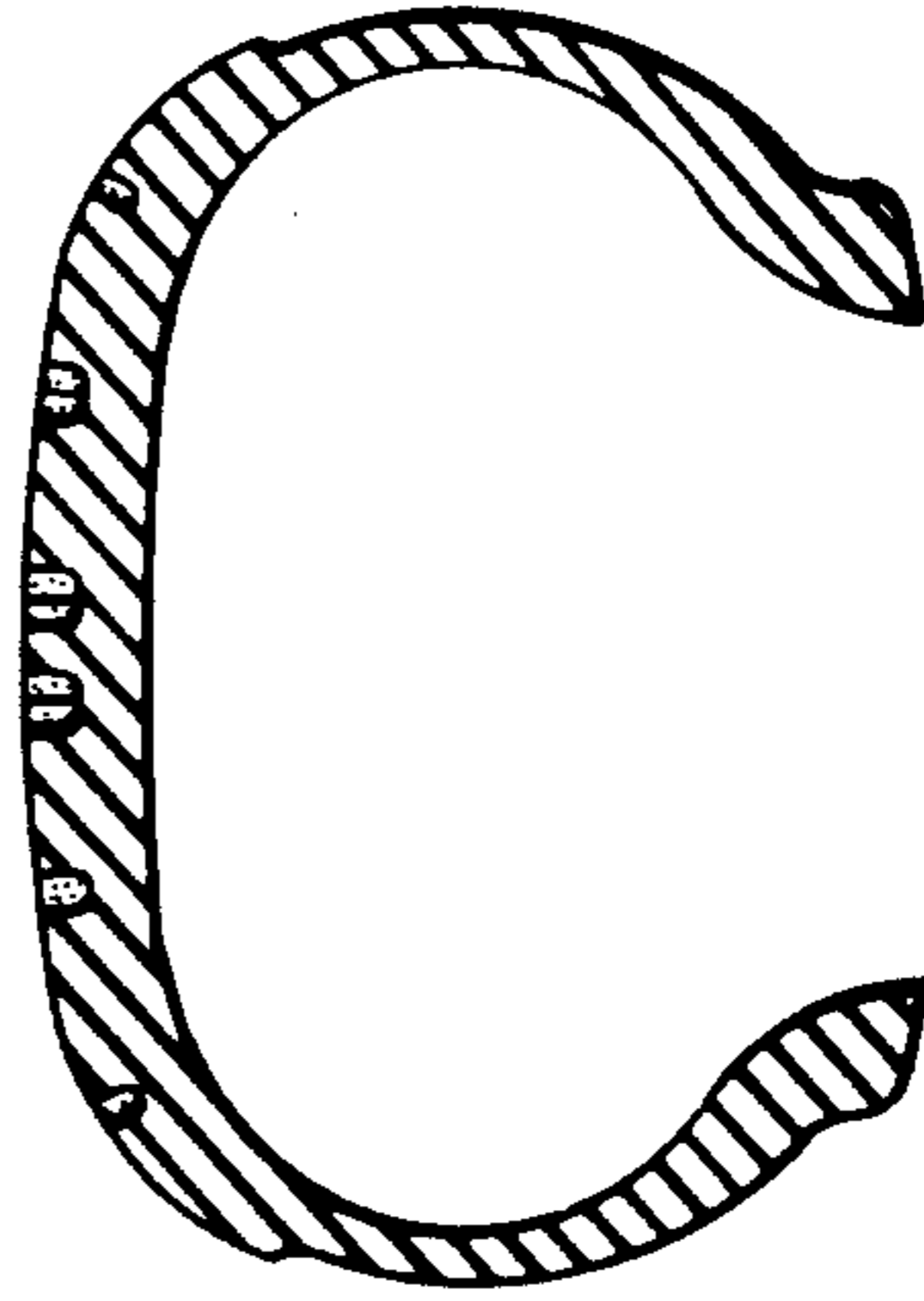

FIG. 3

