

[54] THREE-WHEELED VEHICLE FRAME

[76] Inventors: **George C. Moore; Jodele Moore**, both of 628 Brookway La., Las Vegas, Nev. 89109; **James M. Tipke**, 2823 N. Perry St., Spokane, Wash. 99207

[**] Term: **14 Years**

[21] Appl. No.: **879,712**

[22] Filed: **Feb. 21, 1978**

[51] Int. Cl. **D12-11**

[52] U.S. Cl. **D12/112; D12/85**

[58] Field of Search **D12/110, 112, 85; 180/25 R, 26 R, 27; 280/202, 282, 274**

[56] **References Cited**

U.S. PATENT DOCUMENTS

- D. 35,713 2/1902 Turner D12/85
- D. 250,944 1/1979 Moore et al. D12/85

FOREIGN PATENT DOCUMENTS

416350 11/1946 Italy 280/202

OTHER PUBLICATIONS

Industrial Equipment News, 12/73, p. 11, Three Wheeled Vehicle, top right side of page.

Primary Examiner—James M. Gandy
Attorney, Agent, or Firm—Carlisle M. Moore

[57] **CLAIM**

The ornamental design for a three-wheeled vehicle frame, substantially as shown and described.

DESCRIPTION

FIG. 1 is a top, front isometric view of a three wheeled vehicle frame showing our new design; FIG. 2 is a bottom, rear isometric view thereof; FIG. 3 is a side elevational view thereof; FIG. 4 is a front elevational view thereof; and FIG. 5 is a rear elevational view thereof.

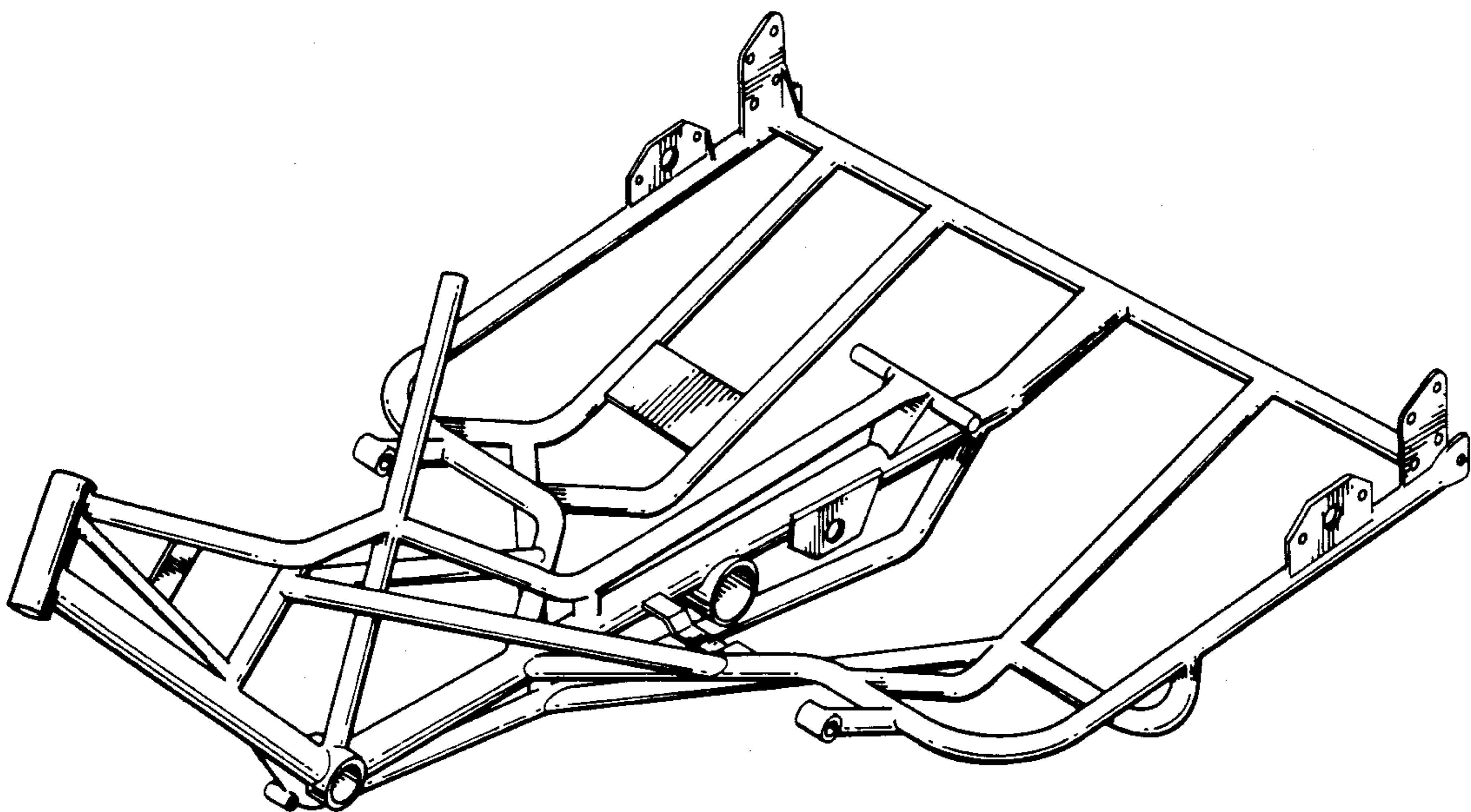

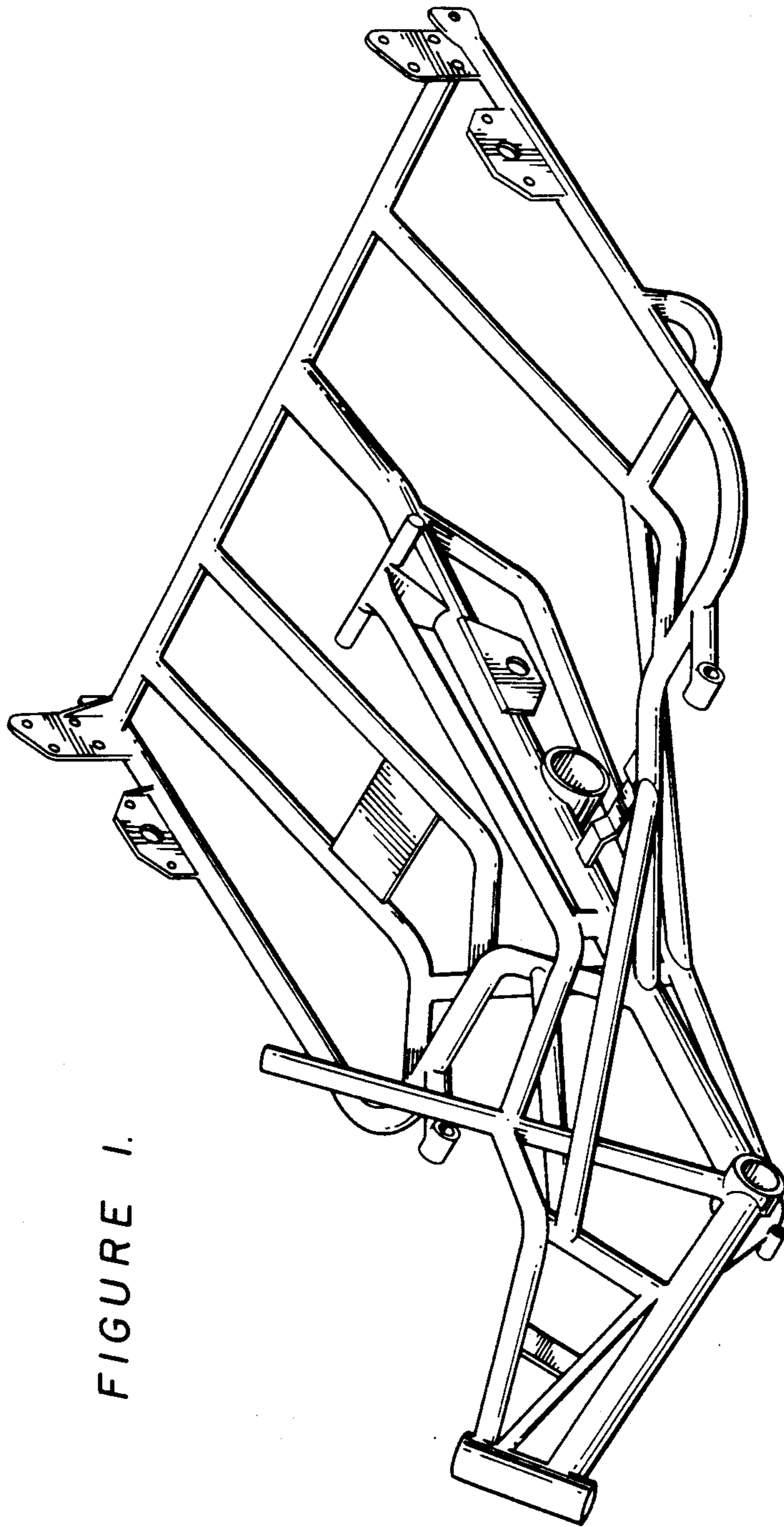

FIGURE 1.

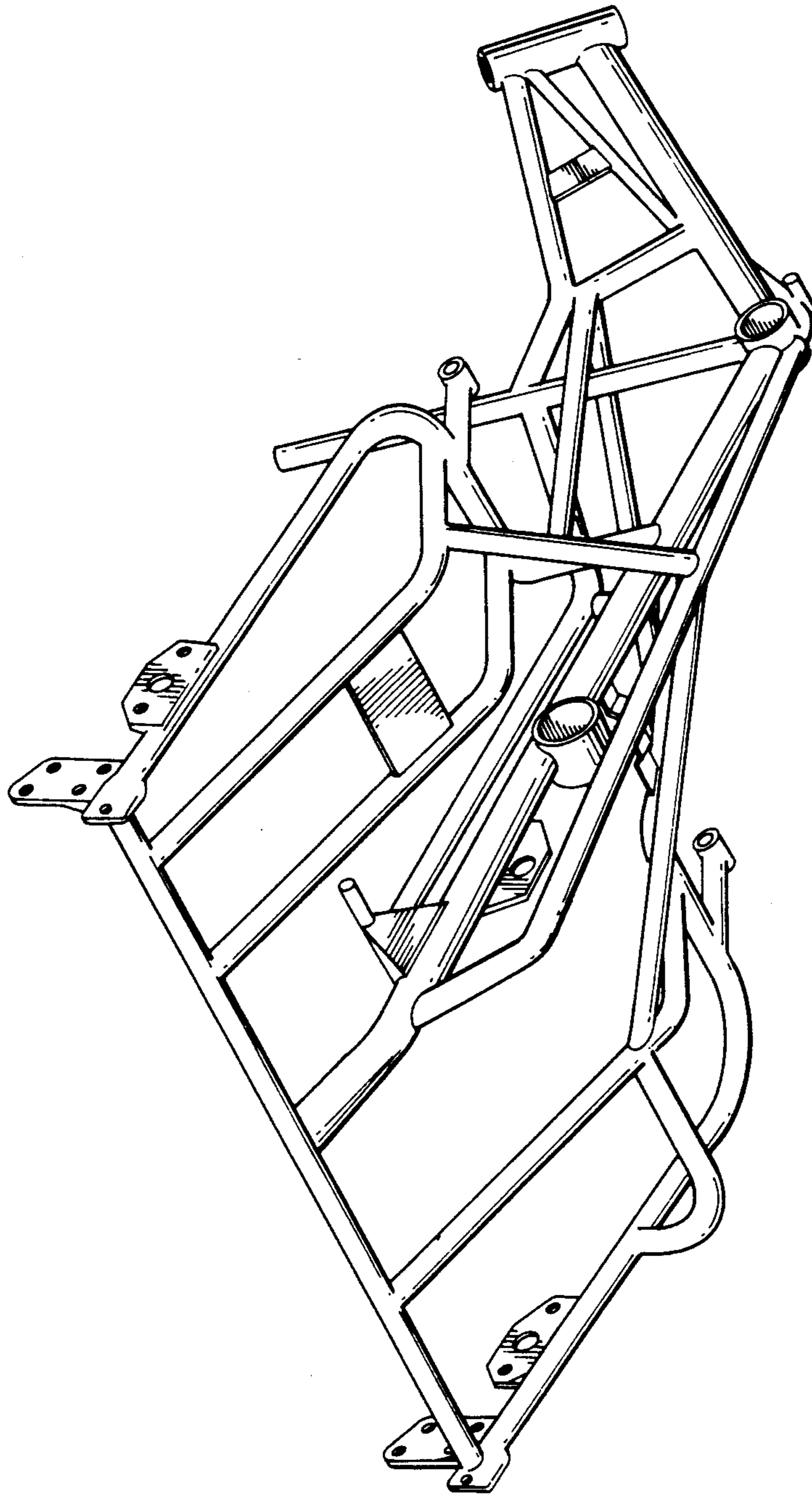

FIGURE 2.

FIGURE 4.

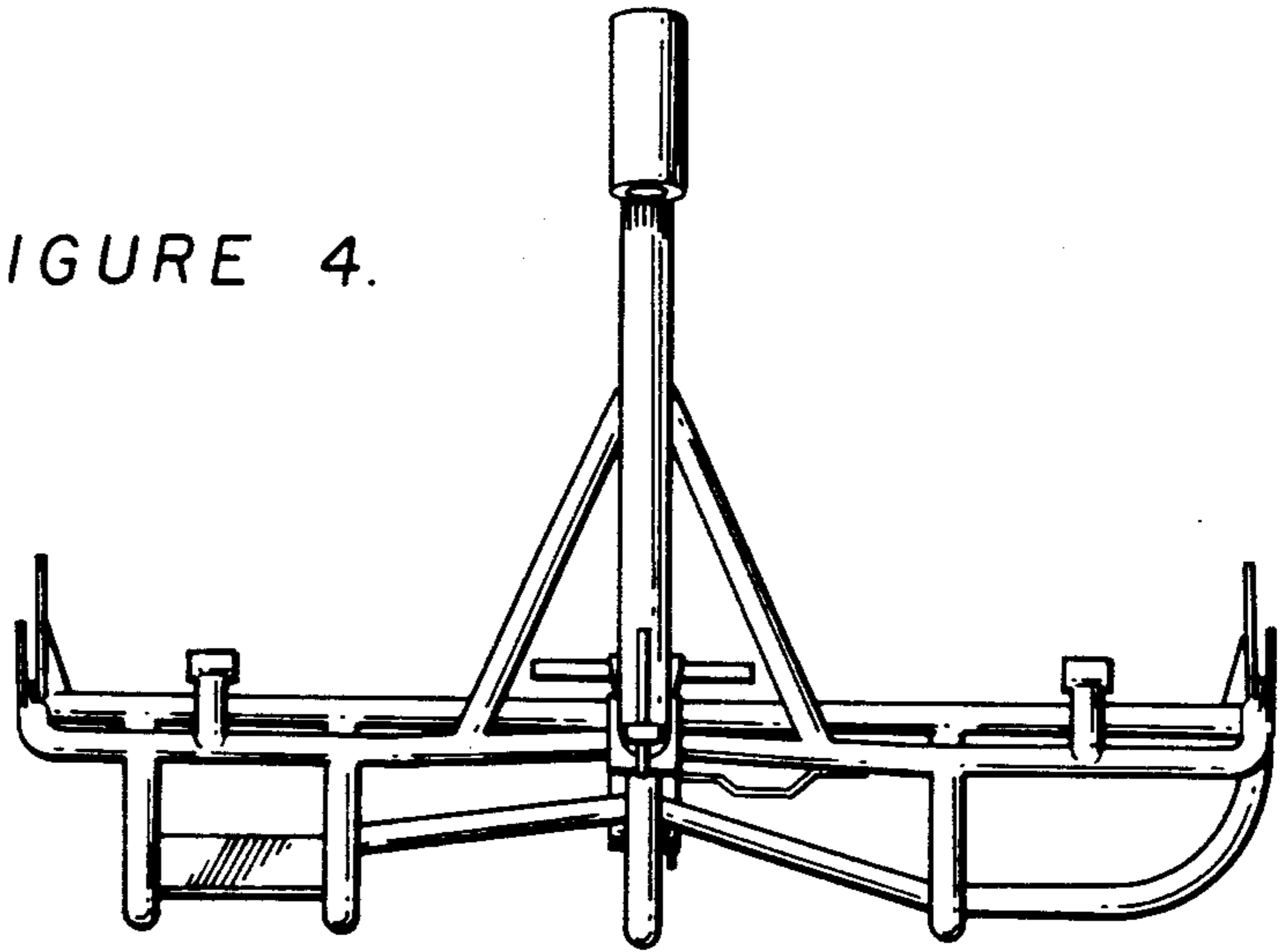

FIGURE 3.

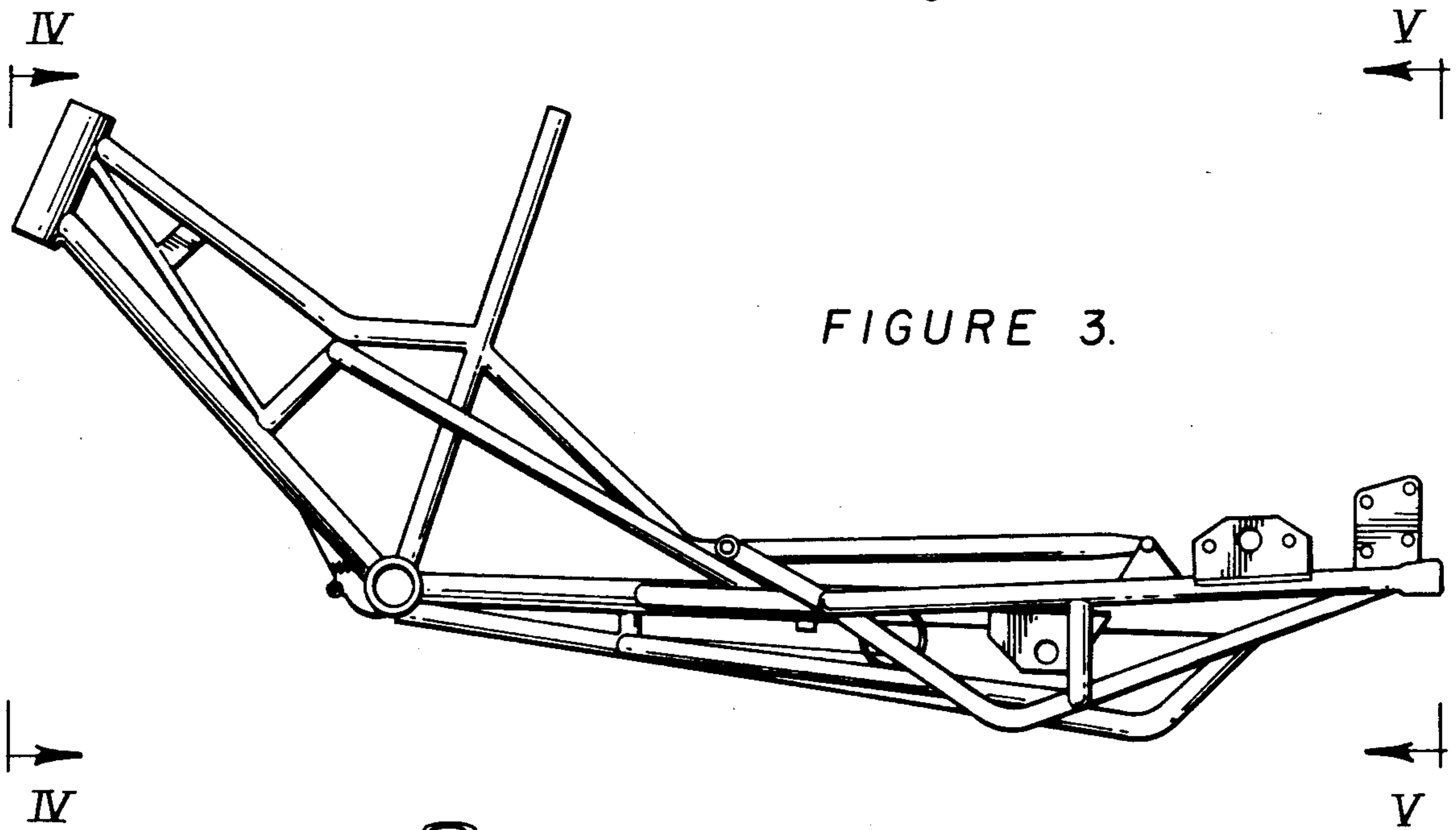

FIGURE 5.

