

[54] AUTOMOBILE BODY

[76] Inventor: Vito J. Carabetta, 124 W. Avenue 42, Los Angeles, Calif. 90065

[**] Term: 14 Years

[21] Appl. No.: 949,687

[22] Filed: Oct. 10, 1978

Related U.S. Application Data

[62] Division of Ser. No. 876,854, Feb. 10, 1978.

[51] Int. Cl. D12-08

[52] U.S. Cl. D12/90

[58] Field of Search D12/90, 91; D34/15 AJ; 296/15, 28 R, 31 P

References Cited

U.S. PATENT DOCUMENTS

D. 233,831 12/1974 Haga et al. D12/91

OTHER PUBLICATIONS

Road & Track, 3/73, p. 44, Lotus Esprit.
Popular Science, 7/74, p. 65, Sleek Bug, center left side of page.

Motor Trend, 9/71, p. 100, Lamborghini Countach.
Motor Trend, 9/72, p. 99, Pantera, top & bottom of page.

Primary Examiner—James M. Gandy
Attorney, Agent, or Firm—Frank A. Frisenda, Jr.

[57] CLAIM

The ornamental design for an automobile body, as shown and described.

DESCRIPTION

FIG. 1 is a side elevational view of an automobile body showing my new design, it being understood that the opposite side is a mirror image thereof;
FIG. 2 is a top plan view thereof;
FIG. 3 is a front elevational view thereof; and
FIG. 4 is a rear elevational view thereof.

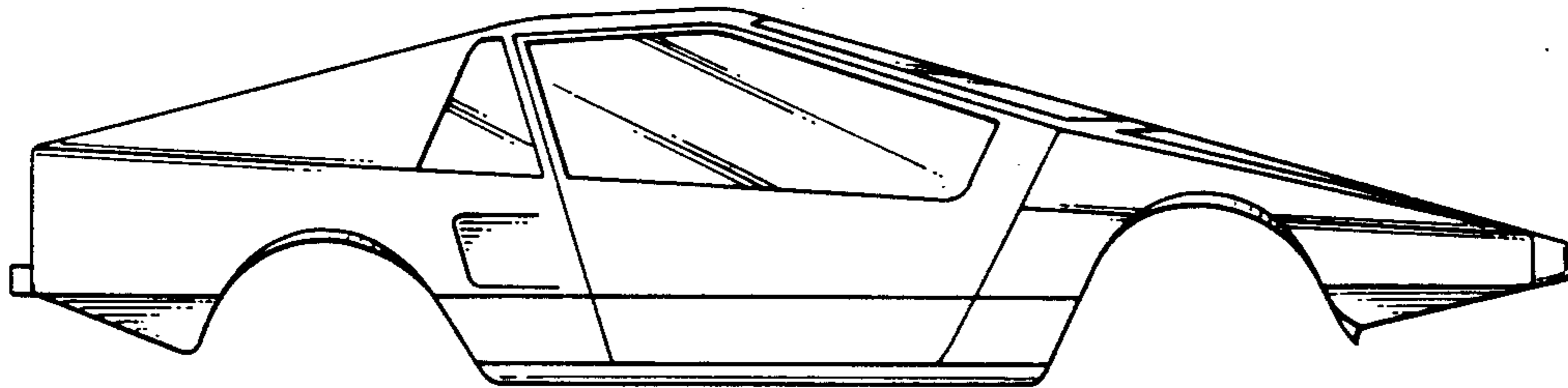

FIG. 1.

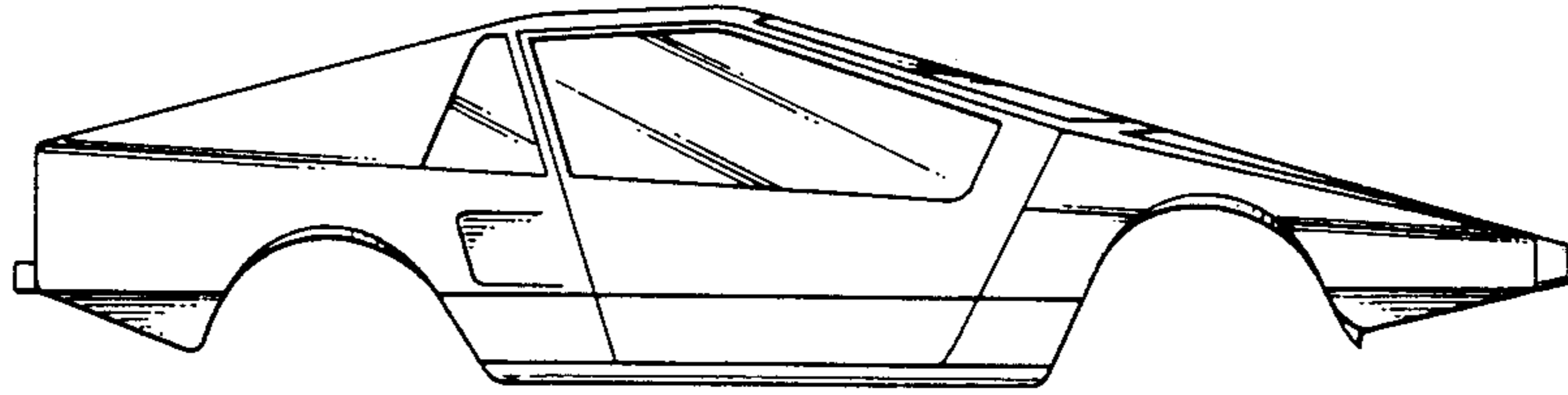

FIG. 2.

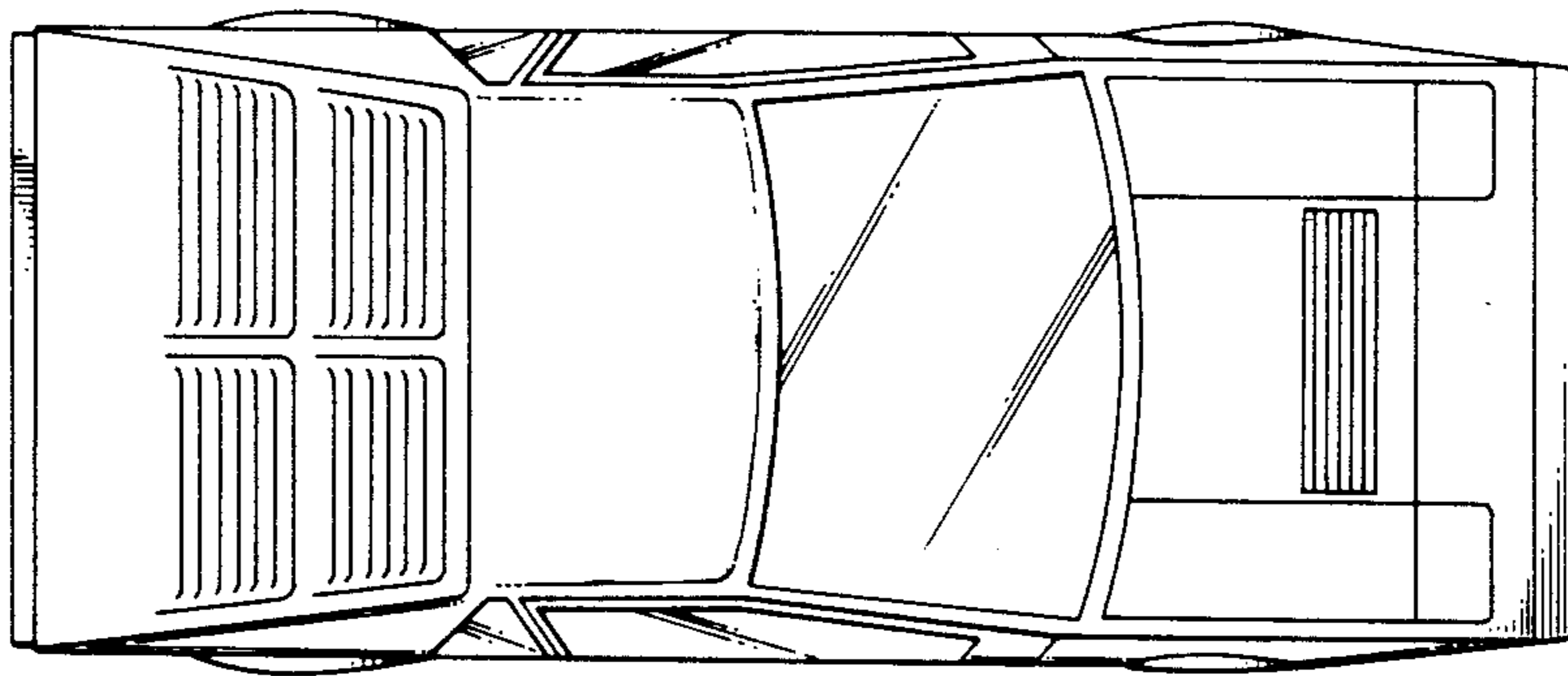

FIG. 3.

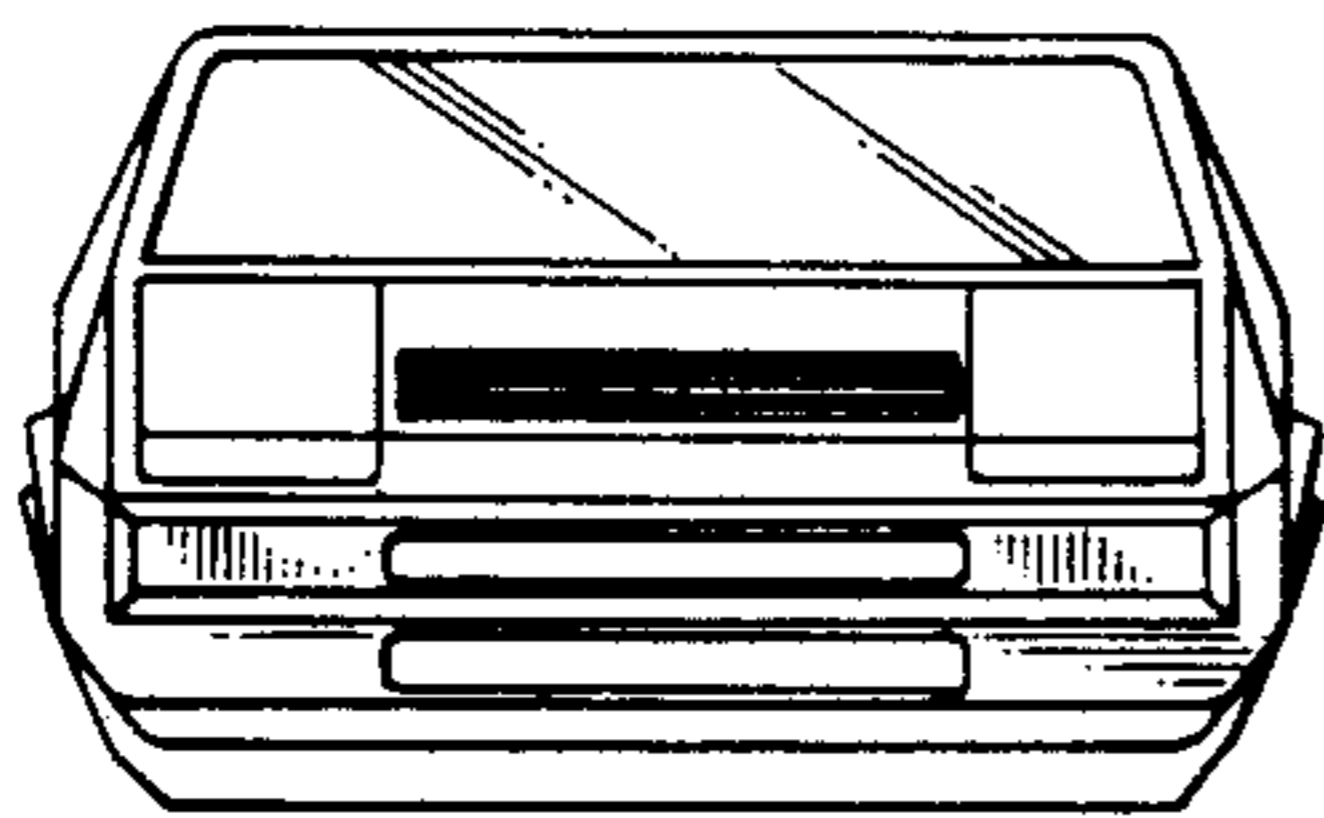

FIG. 4.

