

[54] VEHICLE PANEL GUARD

[76] Inventor: Richard E. Lauer, 6128 Ridgeway, Edina, Minn. 55436

[**] Term: 14 Years

[21] Appl. No.: 856,199

[22] Filed: Nov. 30, 1977

[51] Int. Cl. D12-16

[52] U.S. Cl. D12/190

[58] Field of Search D12/184, 190; 280/153 R, 153 A, 153 B, 159

[56] References Cited

U.S. PATENT DOCUMENTS

D. 247,359 2/1978 Ewen D12/190

OTHER PUBLICATIONS

J. C. Whitney Catalog No. 349, ©1976, p. 132, Gravel Shield (D) for Volkswagen, lower right side of page.

Primary Examiner—James M. Gandy
Attorney, Agent, or Firm—Robert W. Gutenkauf

[57] CLAIM

The ornamental design for a vehicle panel guard, substantially as shown and described.

DESCRIPTION

FIG. 1 is a side elevational view of a vehicle panel guard showing my new design installed along the forward edge of the rear wheel well of a truck type vehicle which has been fragmentarily shown in broken lines for illustrative purposes only;

FIG. 2 is an enlarged rear elevational view thereof;

FIG. 3 is an enlarged side elevational view thereof;

FIG. 4 is an enlarged front elevational view thereof;

FIG. 5 is an enlarged top plan view thereof;

FIG. 6 is an enlarged bottom plan view thereof;

FIG. 7 is an enlarged side elevational view thereof opposite to that shown in FIG. 3; and

FIG. 8 is an enlarged perspective view thereof.

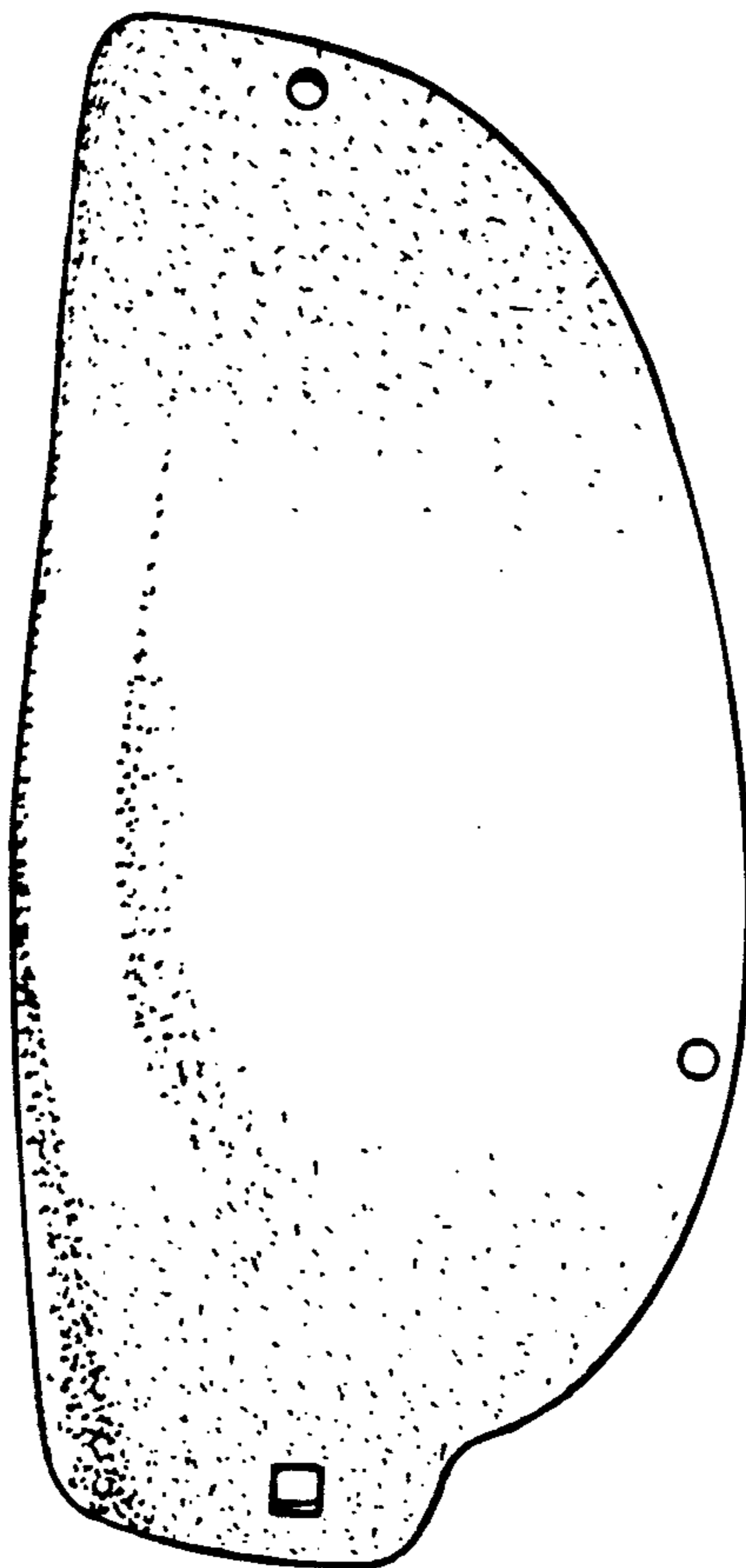

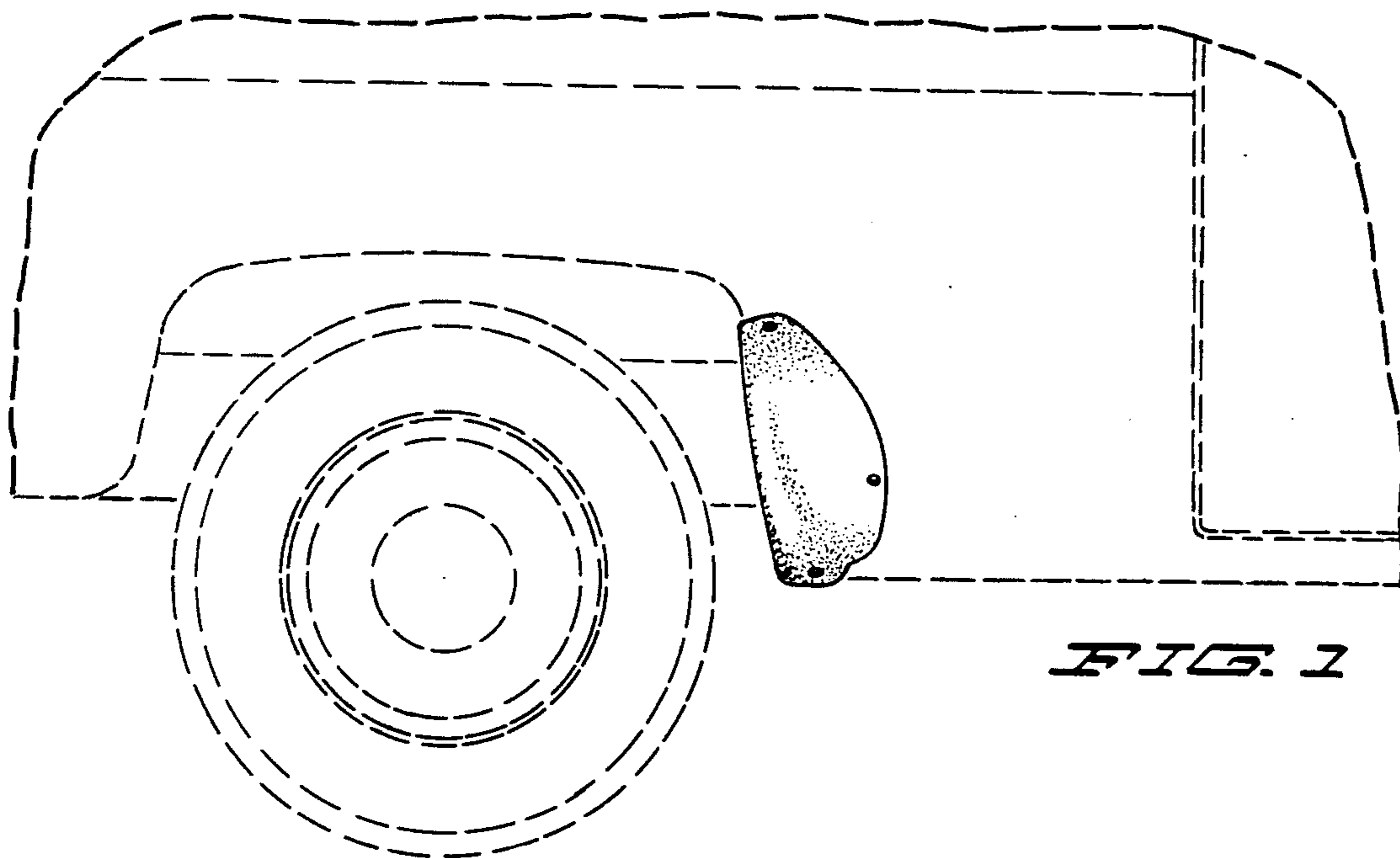

FIG. 1

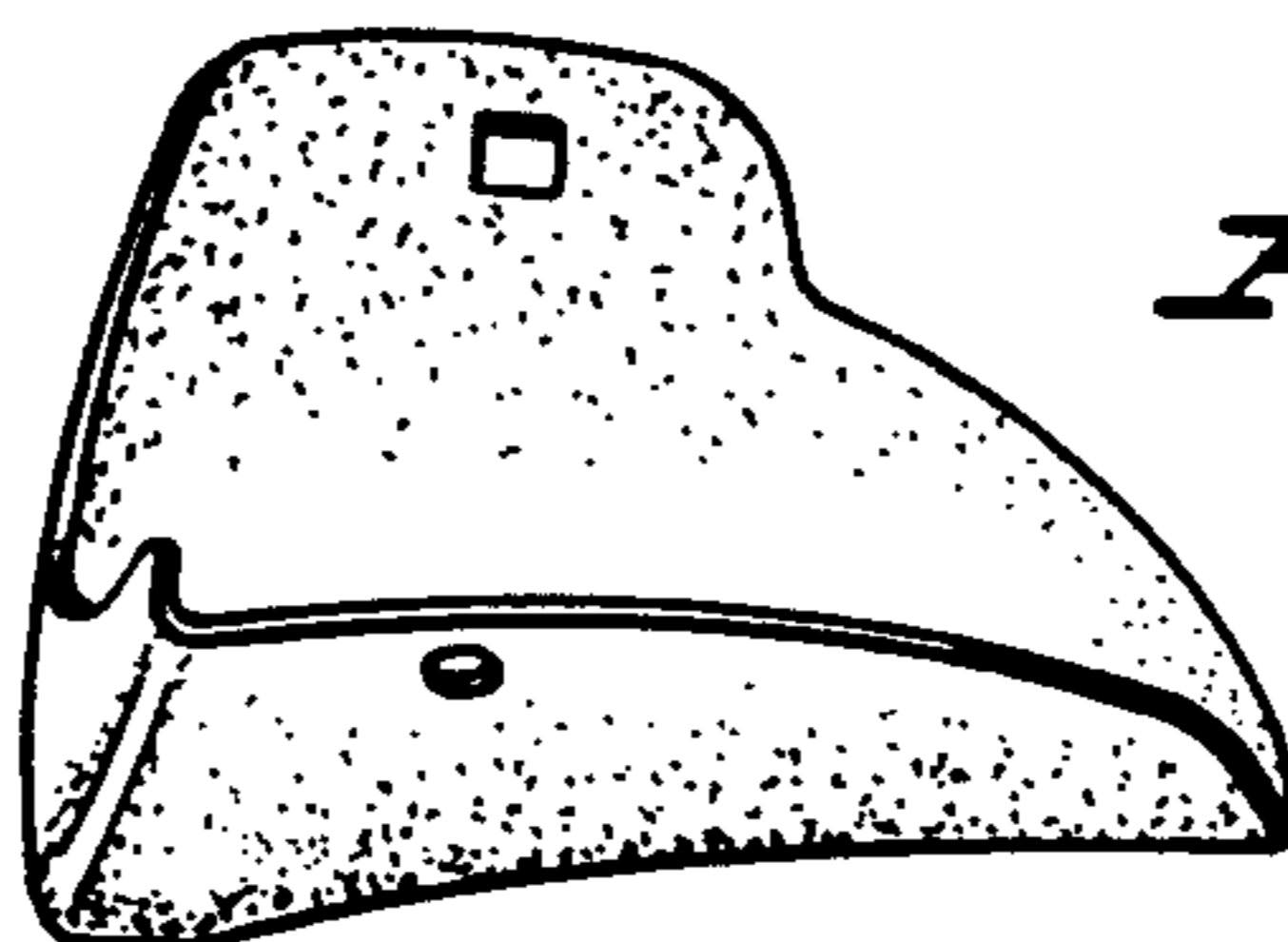

FIG. 5

FIG. 2

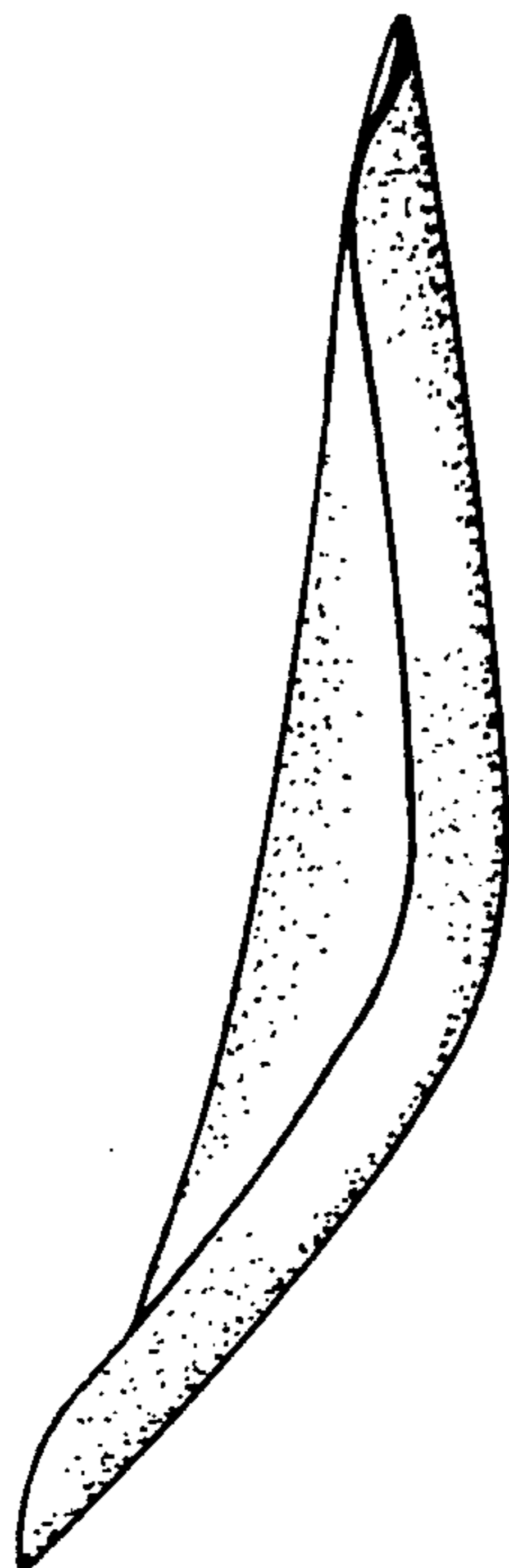

FIG. 4

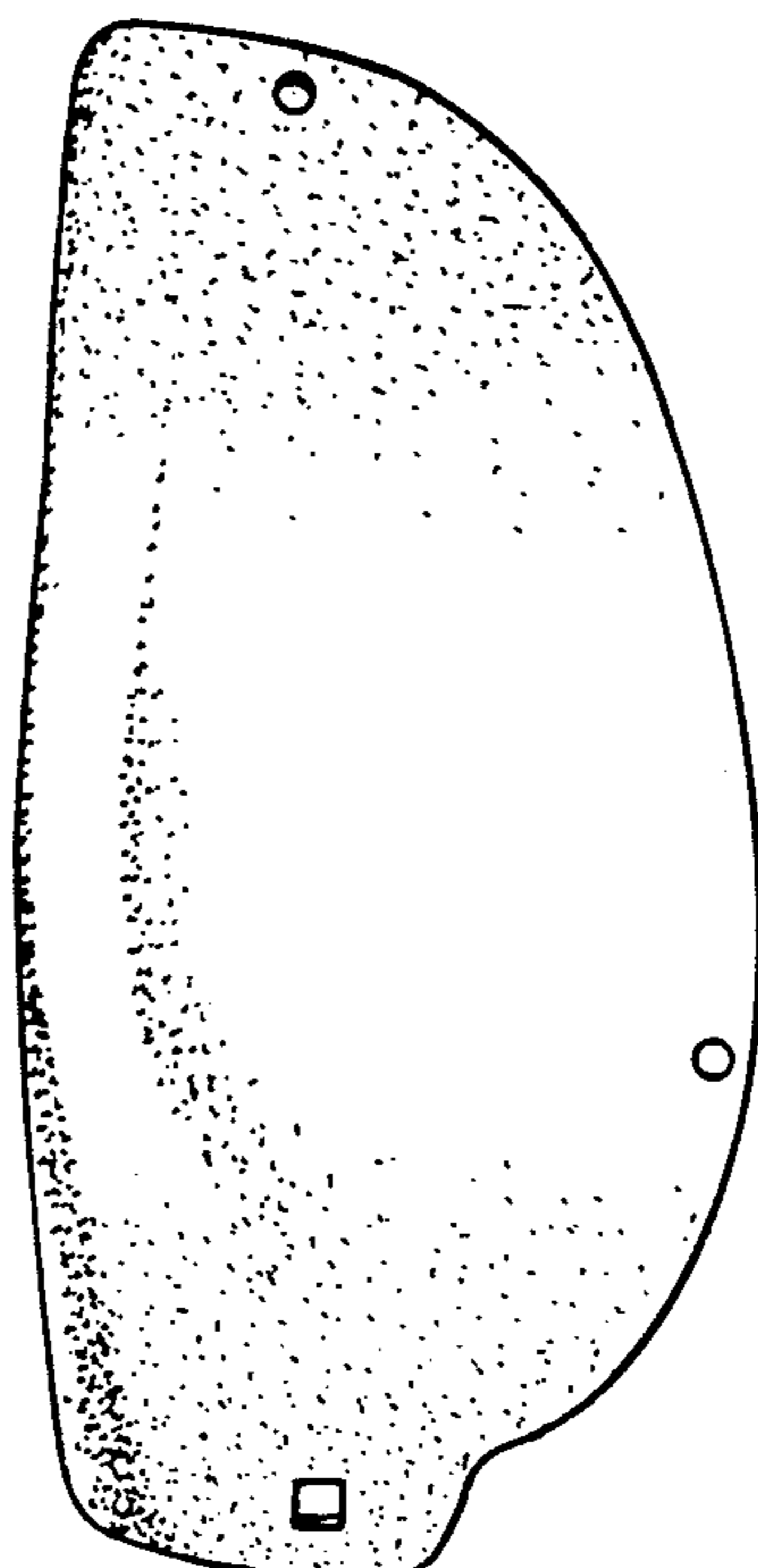
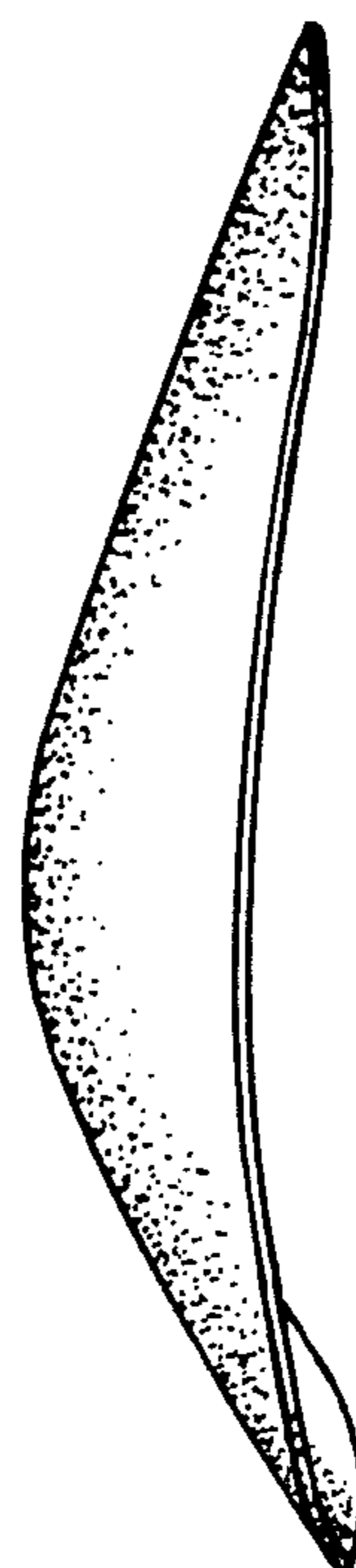

FIG. 3

FIG. 6

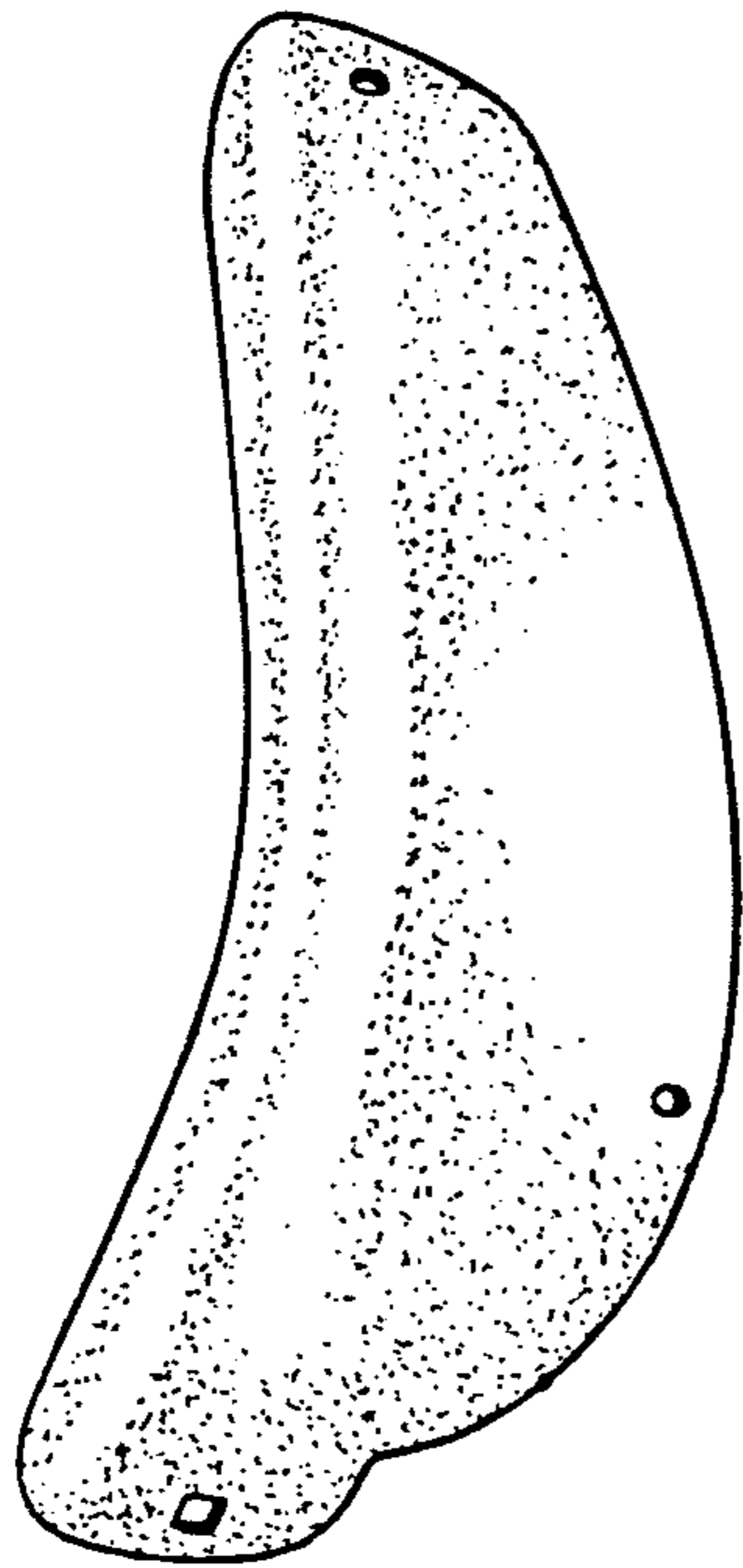
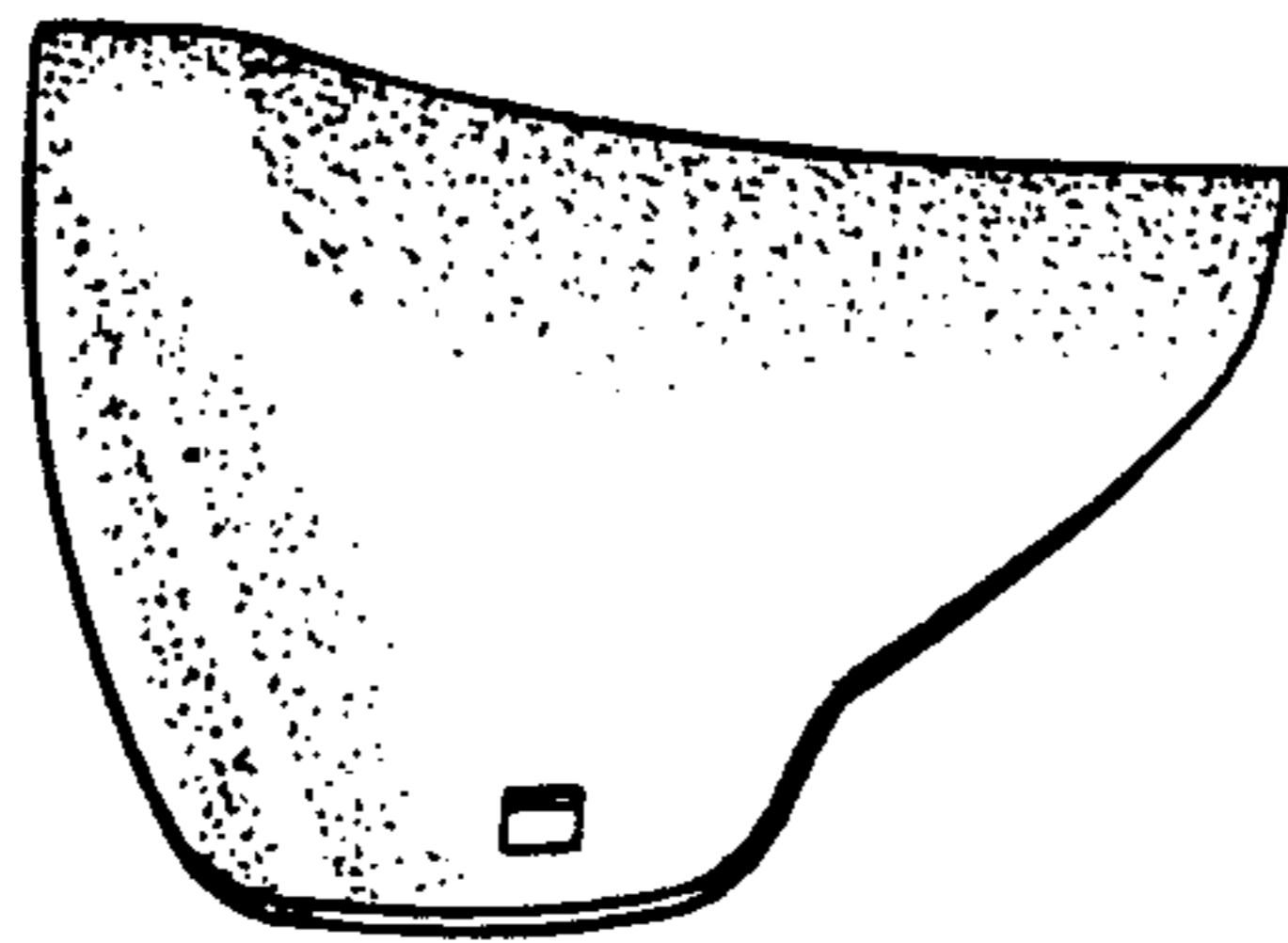

FIG. 8

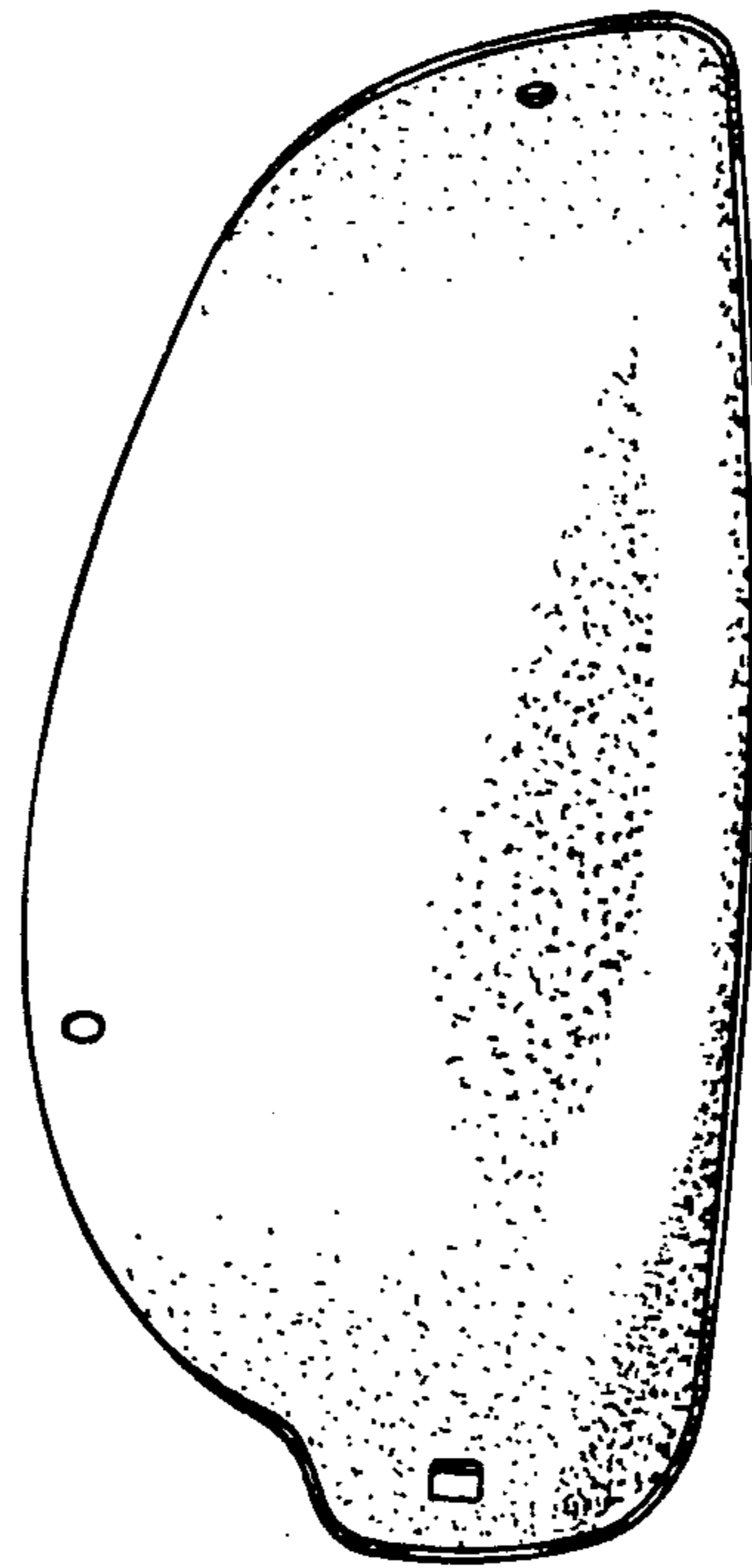

FIG. 7