

[54] COMBINED PICKUP CAB CARRIER AND ROLL BAR

[76] Inventor: Robert Ramirez, 3003 Douglas St., Dallas, Tex. 75219

[\*\*] Term: 14 Years

[21] Appl. No.: 841,537

[22] Filed: Oct. 12, 1977

[51] Int. Cl. .... D12-16

[52] U.S. Cl. .... D12/156; D12/157

[58] Field of Search .... D12/156, 157, 195; 224/42.1 R, 42.1 D, 42.1 E; 296/37.6, 37.7; 280/756

[56] References Cited

U.S. PATENT DOCUMENTS

D. 221,750 9/1971 Downey et al. .... D12/157

D. 229,688 12/1973 Feth .... D12/195

4,057,281 11/1977 Garrett ..... D12/156

Primary Examiner—James M. Gandy  
Attorney, Agent, or Firm—D. Carl Richards

[57] CLAIM

The ornamental design for a combined pickup cab carrier and roll bar, as shown and described.

DESCRIPTION

FIG. 1 is a perspective view of a combined pickup cab carrier and roll bar showing my new design, it being understood that the broken lines are for illustrative purposes only;

FIG. 2 is an enlarged side elevational view thereof, the opposite side being substantially a mirror image of the side shown therein;

FIG. 3 is an enlarged rear elevational view thereof; and FIG. 4 is an enlarged front elevational view thereof.

The broken lines in FIG. 1 of the drawing are for illustrative purposes only.

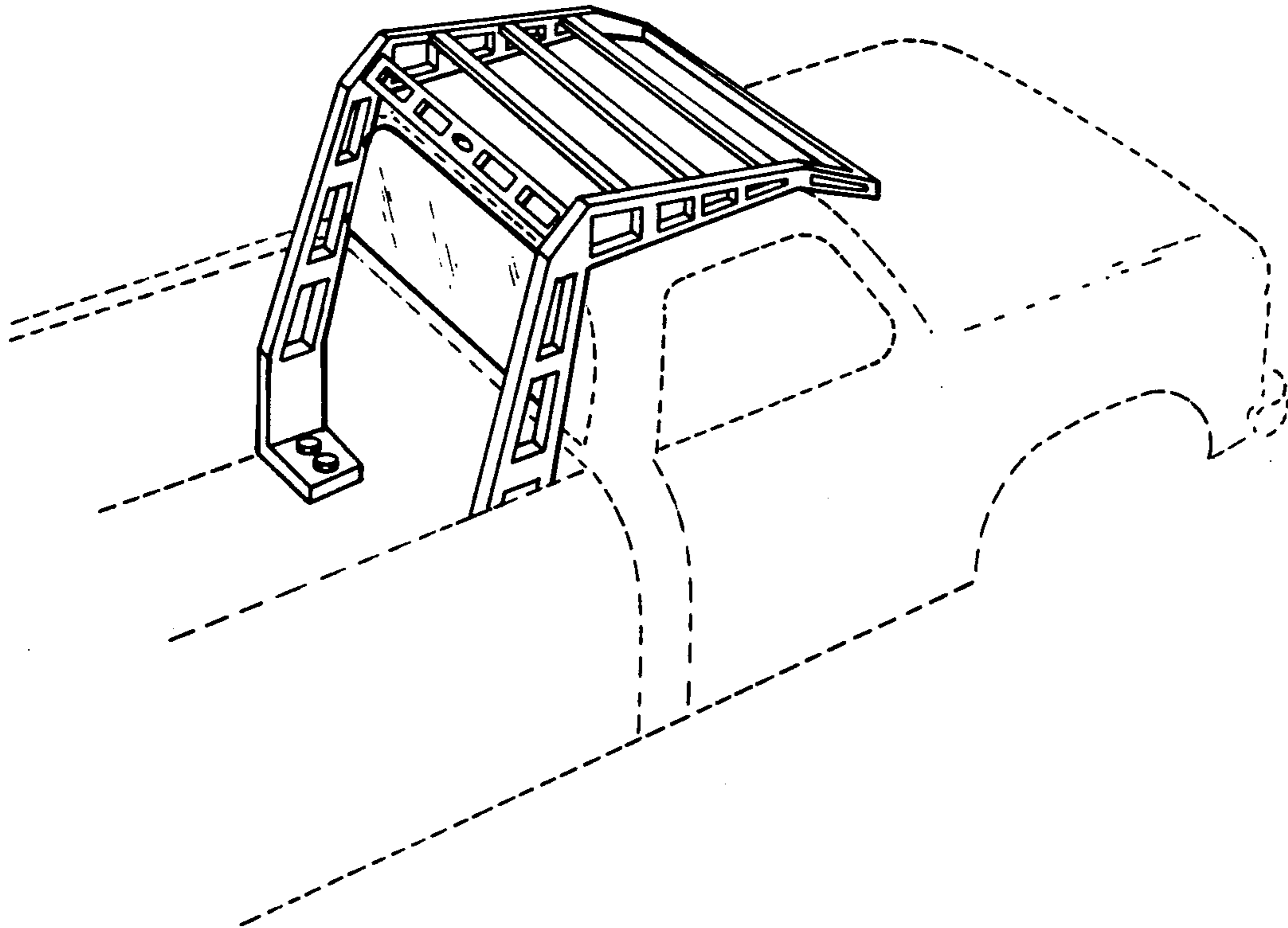

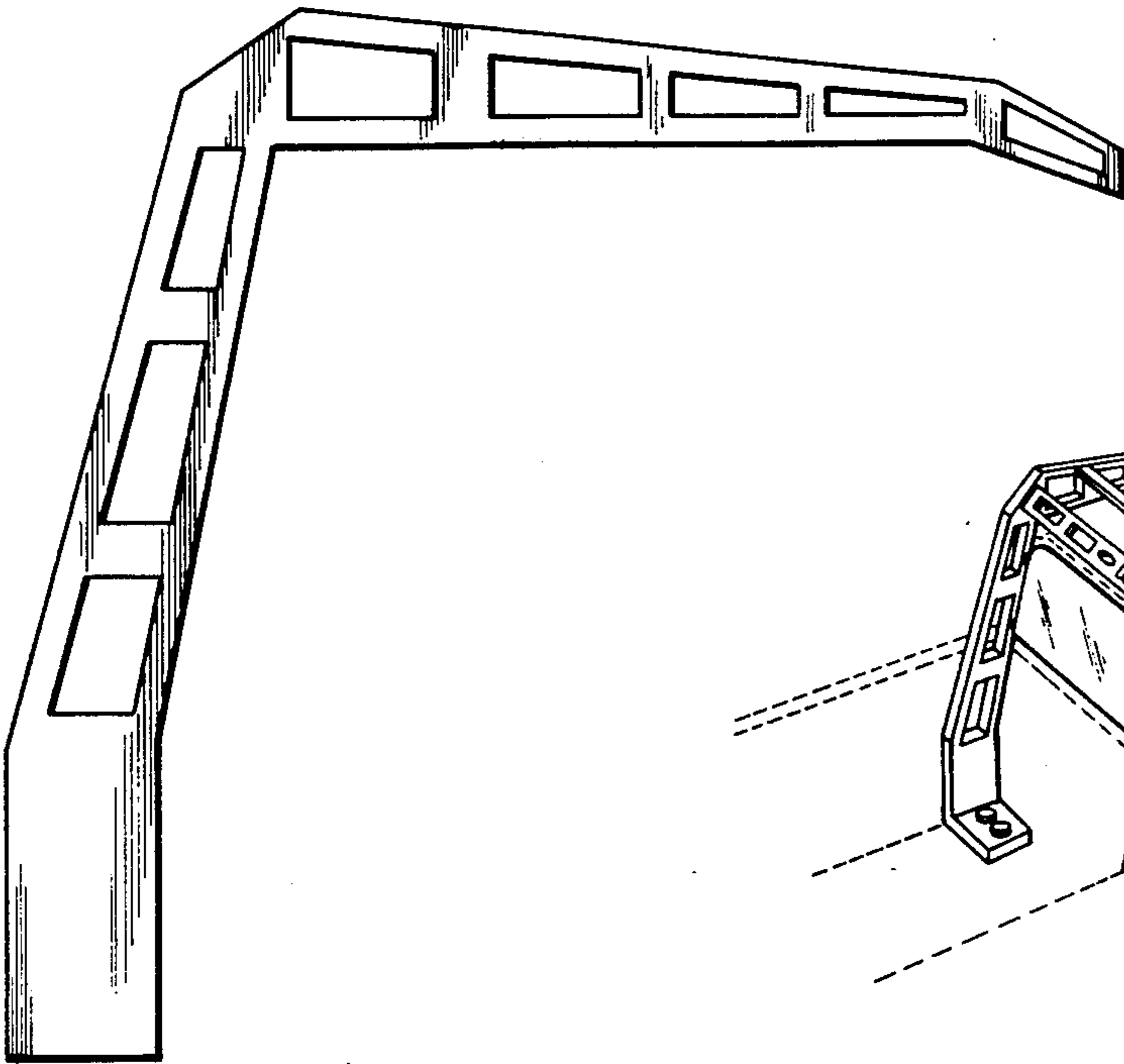

FIG. 2

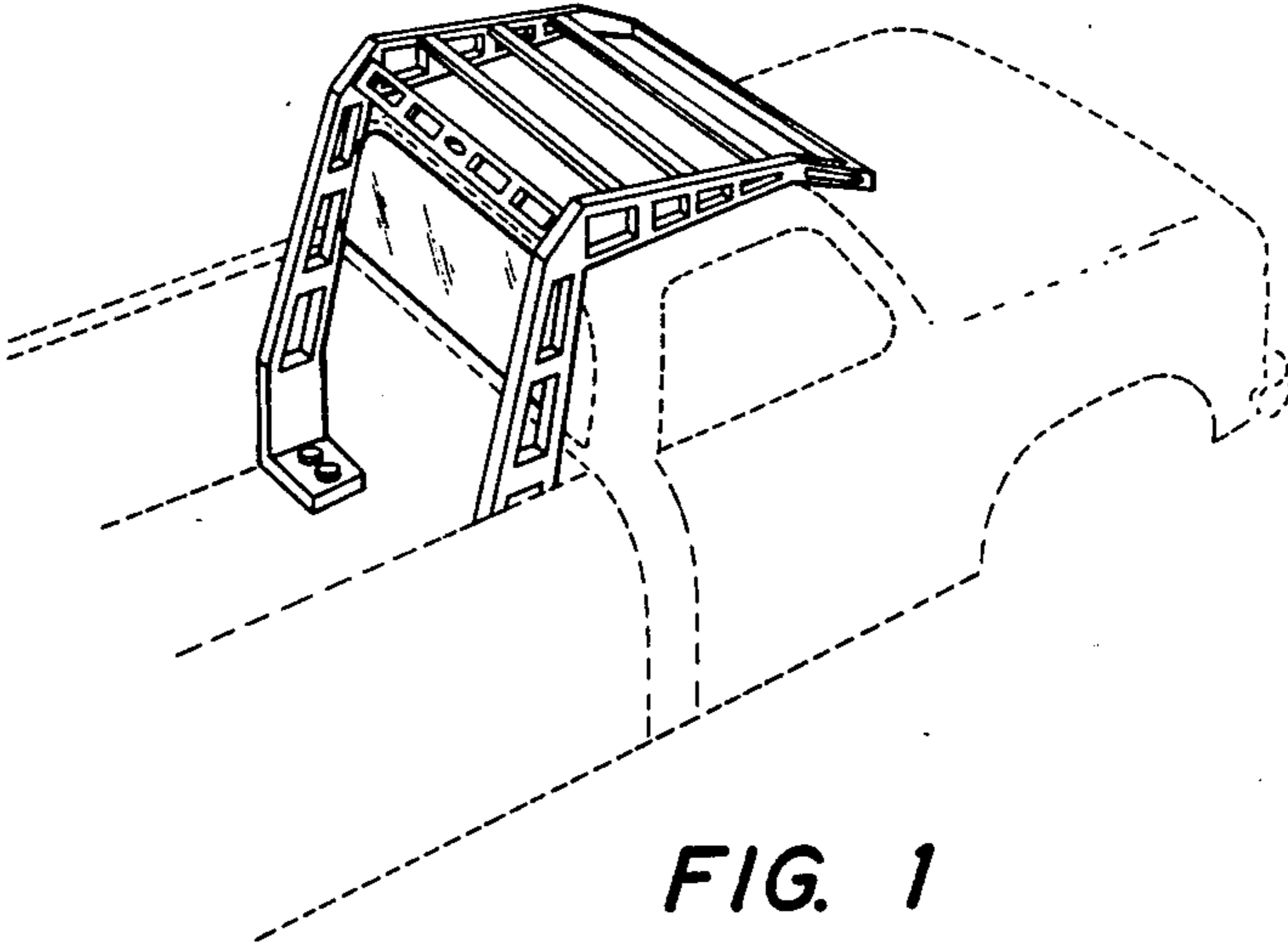

FIG. 1

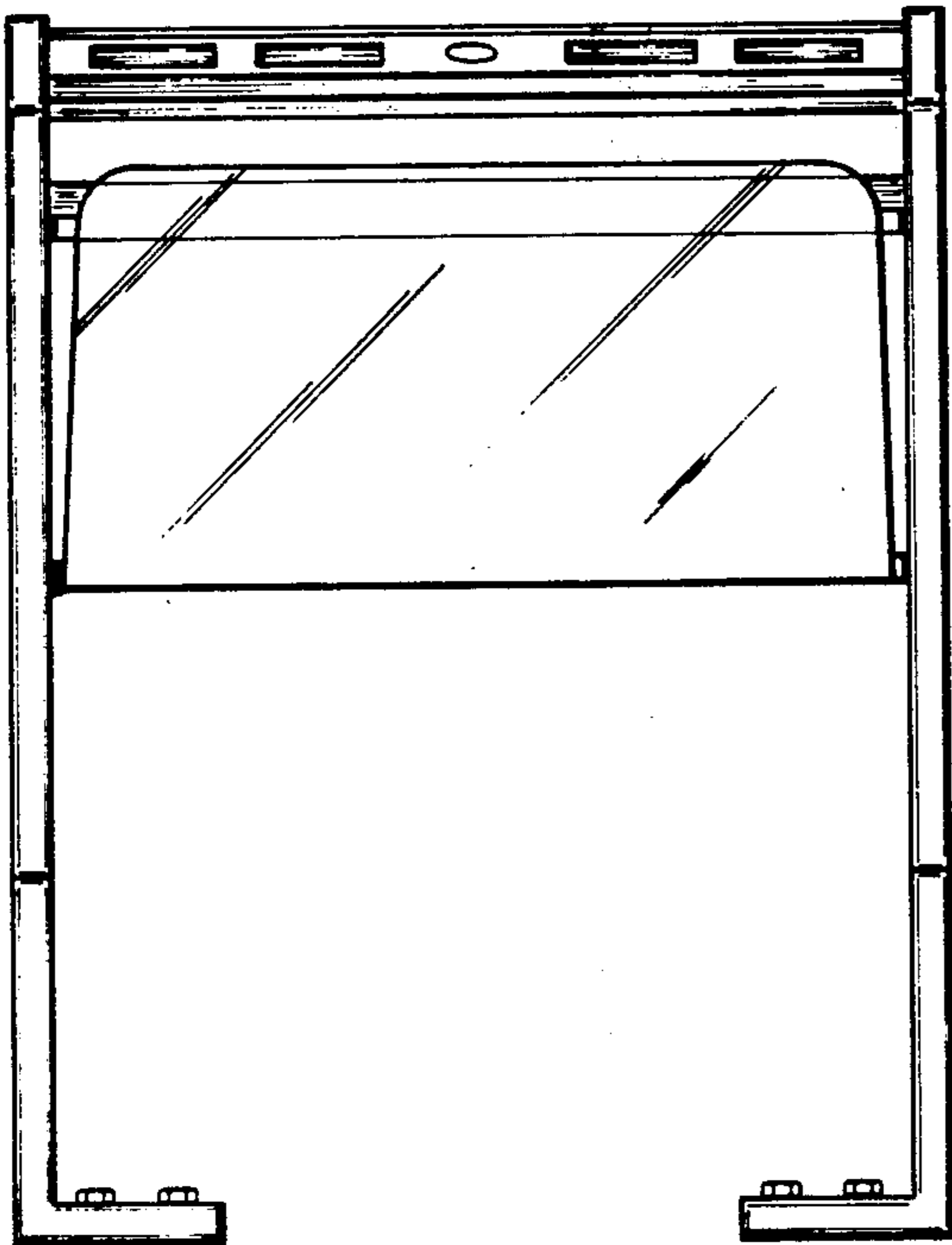

FIG. 3

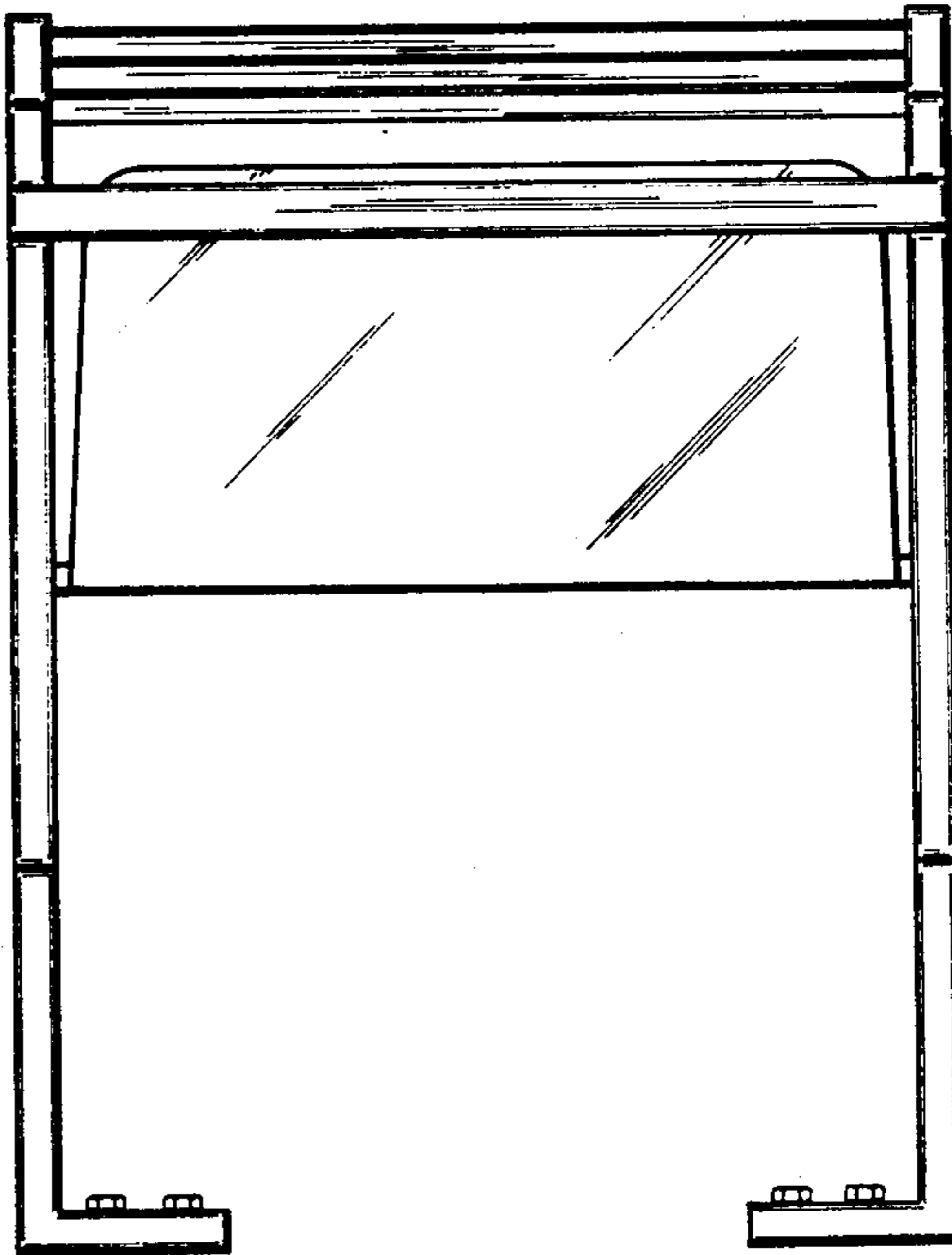

FIG. 4